



**RAIMONDI**®  
SINCE 1863

## **2019 PRODUCT GUIDE**

**[www.raimondi.co](http://www.raimondi.co)**

PRECISION EUROPEAN CRAFTSMANSHIP



[www.raimondi.co](http://www.raimondi.co)



**Raimondi Cranes is proudly headquartered in our ancestral home of Legnano**

Corso Garibaldi, 253 - 20025 Legnano - Milan, Italy

T +39 0331 548 061 r.a. | +39 0331 545 308 r.a. | F +39 0331 450 400 | [info@raimondicranes.com](mailto:info@raimondicranes.com)

DATA SHEETS REV.00.2019 / ADL



© All rights reserved Raimondi Cranes 2019



**The data presented in the 2019 Product Guide is subject to change without prior notice. Being an non-binding commercial document, the reader is required to consult instruction manuals for all technical information.** / I dati oggetto della presente scheda potrebbero subire modifiche senza preavviso. Essendo un documento commerciale non vincolante si fa obbligo di consultare il manuale di istruzioni per tutte le informazioni tecniche. / Les informations données dans les fiches présentes peuvent subir des modifications sans préavis. Étant un document commercial non contraignant, il est nécessaire de consulter le manuel d'instructions pour toutes les informations techniques. / Die daten der vorliegenden blätter könnten ohne vorankündigung geändert werden. Unverbindliches Vertriebsdokument. Für technische Informationen, siehe die entsprechenden Anweisungen. / данные, указанные в настоящих спецификациях, могут изменяться без предварительного предупреждения. Этот коммерческий документ не является юридически обязательным. Для получения технической информации, см. соответствующие инструкции.





The Raimondi MRT159 topless tower crane erected in Milan, Italy. The 8 tonne topless tower crane has a 65 meter jib and HUH of 54 meters



## Table of contents

### 8 **TOPLESS CRANES**

9 MRT48

25 MRT84

39 MRT111

57 MRT159

79 MRT189

95 MRT234

113 MRT294

### 128 **LUFFING CRANES**

129 LR60

147 LR213

163 LR273

177 LR330

189 LR372 rev 01

201 LRH174





### 214 **ACCESSORIES**

216 BASE 8X8





218 SERVICE BALCONY KIT

220 TOWER CRANE LIFT





222 DELUXE R16 CABIN

**MRT**     

	m	t	35	39	42	45	51	54	60	65	70	76	
<b>48</b>	34,8	4,0	1,37									9	
<b>84</b>	41,0	5,0	1,26									25	
<b>111</b>	47,0	8,0	1,26									39	
<b>159</b>	47,8	8,0	1,82									57	
<b>189</b>	45,1	10,0	2,20									79	
<b>234</b>	42,2	12,0	2,25									95	
<b>294</b>	57,9	16,0	2,58									113	

**LR** **HT**    

	m	t	36	45	50	55	60	
<b>60</b>	31,1	5,0	1,43					129
<b>213</b>	49,1	14,0	2,25					147
<b>273</b>	84,4	18,0	2,86					163
<b>330</b>	84,4	18,0	3,52					177
<b>372</b>	84,4	20,0	3,80					189

**LRH** **HT**    

	m	t	36	45	50	55	
<b>174</b>	54,9	10,0	2,48				201

DEALER - DISTRIBUTORE - DISTRIBUTEUR - DISTRIBUTOR - ДИСТРИБЬЮТОР





**RAIMONDI**®  
SINCE 1863

**TOPLESS CRANES**

The Raimondi MRT294 topless tower crane remains one of the company's most popular models due to its lifting capacity and its durability in a variety of climates



The MRT48 with an of HUH 35 m, is one of Raimondi's most popular models and is reputed as an easy, fast, robust, and reliable crane



**RAIMONDI**® MRT48  
SINCE 1863



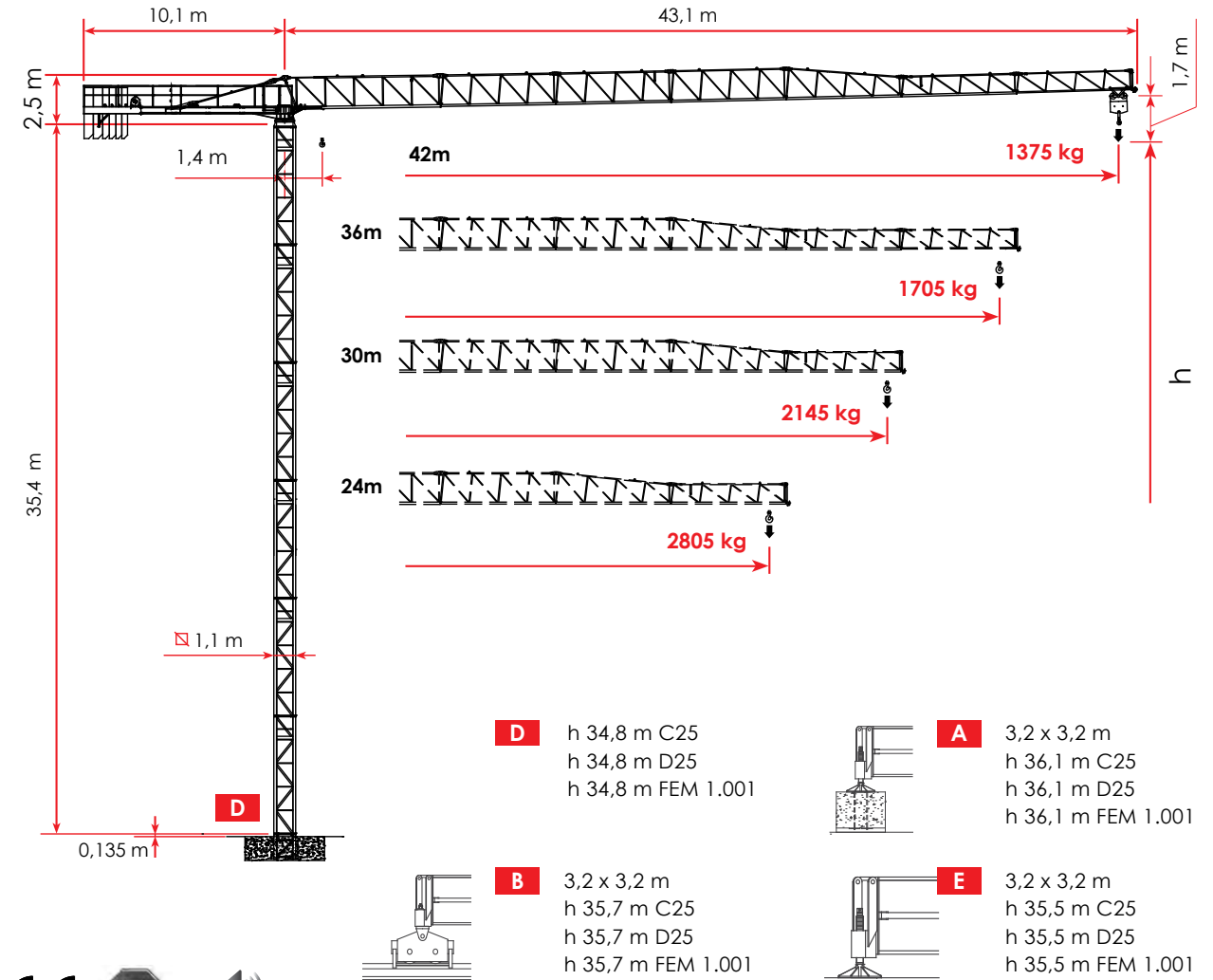











**MRT48**  
4t 







    
2000/14/CE  
A4 EN 14439 C25 D25 - FEM 1.001

TECHNICAL DATA SHEET • MRT48 REV.00.2019

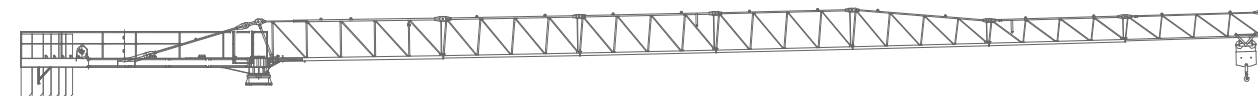







IT	EN	F	DE	RU
 Altezza sotto gancio	Height under hook	Hauteur sous crochet	Höhe unter dem Haken	Высота под крюком
 Contrappesi	Counter weight jib ballast	Lest de contre-flèche	Gegenauslegerballast	Противовесы
 Freccia	Jib	Flèche	Kranarm	стрела крана
 Carico massimo	Max load	Charge maximale	Maximale Belastung	максимальная нагрузка
 Curva di carico Ultralift	Load diagrams with ultralift control	Courbes de charges Ultralift	Lastkurven Ultralift	Кривой Груз Ultralift
 Altezza libera	Free Standing	Hauteur libre	Freistehend	Свободностоящая высота
 Azionamenti	Mechanisms	Mécanismes	Antriebe	Приводы
 Velocità	Speed	Vitesse	Geschwindigkeit	скорость
<b>4* - 5*</b>  Marce con velocità proporzionale al carico	5 step with speed proportional to the load	5 rapports avec une vitesse proportionnelle à la charge	5 Gang Geschwindigkeit proportional zum Last	Автоматический выбор скорости механизма подъема в зависимости от величины груза
 Tiro a 2 funi	Two - rope pull	Tir à deux câbles	Zug an zwei Seilen	Двукратная запасовка тросов
 Tiro a 4 funi	Four - rope pull	Tir à quatre câbles	Zug an vier Seilen	Четырехкратная запасовка тросов
 Totale metri fune tamburo	Total meters rope drum	Total des mètres de corde du tambour	Total Meter Seil Trommel	Запас троса на барабане в метрах
 Diametro fune	Rope diameter	Diamètre du câble	Seildurchmesser	Диаметр троса
 Rotazione	Slewing	Orientation	Schwenken	Поворот
 Carrello	Trolley	Chariot	Katzfahren	Тележка



			MAX 	18 m	24 m	30 m	36 m	42 m
kg	m	2,5 t				kg		
8052	<b>42</b>	24,5	2500	2500	1993	1631	<b>1375</b>	
6348	<b>36</b>	24,0	2500	2500	2081	<b>1705</b>		
5266	<b>30</b>	26,0	2500	2500	<b>2145</b>			
4026	<b>24</b>	24,0	2500	<b>2500</b>				
2786	<b>18</b>	18,0	<b>2500</b>					

 400 V ± 5% 50 Hz    2000 / 14 / CE

2,5 t 15 hp 11 kW		STEP				
			m/min	kg	m/min	kg
 80 m	1	4,4	2500			
 28 kVA	2	22	2500			
 Ø 11 mm	3	44	1250			
	<b>4*</b>	48	200			

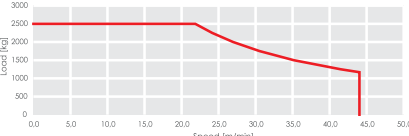







kVA Power required / Potenza richiesta / Puissance requise / Erforderliche Leistung / Потребляемая мощность

 0,37/ 0,70/ 1,0 min<sup>-1</sup> • 4,0 kW /  18,0/ 40,0/ 60,0/ m/min • 2,2 kW  14 m/min • 2 x 2,9 kW

400 V ± 5% 50 Hz   2000 / 14 / CE





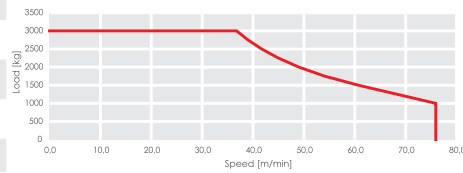

3,0 t 30 hp 22 kW

	STEP				
		m/min	kg	m/min	kg
 240 m	1	7,6	3000		
 45 kVA	2	23	3000		
 Ø 11 mm	3	38	3000		
	4	61	1500		
	5	76	1000		
	5*	91	400		



400 V ± 5% 50 Hz   2000 / 14 / CE

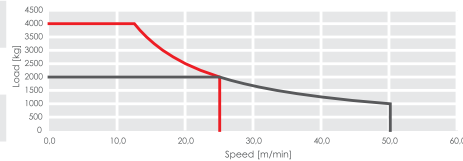

2,0 t/4,0t 15 hp 11 kW

	STEP				
		m/min	kg	m/min	kg
 144 m	1	6,5	2000	3,25	4000
 28 kVA	2	25	2000	12,5	4000
 Ø 9 mm	3	50	1000	25	2000
	4*	60	200	30	400





kVA Power required / Potenza richiesta / Puissance requise / Erforderliche Leistung / Потребляемая мощность

\* Speed automatically controlled by a current sensor / Velocità regolata automaticamente da sensore di corrente / Vitesse réglée automatiquement par capteur de courant / Automatisch durch Stromsensor geregelte geschwindigkeit / скорость АВТОМАТИЧЕСКИ КОНТРОЛИРУЕТСЯ ДАТЧИКОМ НАПРЯЖЕНИЯ

 0,37/ 0,70/ 1,0 min<sup>-1</sup> • 4,0 kW /  18,0/ 40,0/ 60,0/ m/min • 2,2 kW  14 m/min • 2 x 2,9 kW





MRT48 - 2,5t

JIB	18	24	30	36	42
1,4 ▶	18,0	24,0	26,0	24,0	24,5
10	2500	2500	2500	2500	2500
12	2500	2500	2500	2500	2500
14	2500	2500	2500	2500	2500
16	2500	2500	2500	2500	2500
18	2500	2500	2500	2500	2500
20	2500	2500	2500	2500	2500
22	2500	2500	2500	2500	2500
24	2500	2500	2500	2500	2500
26			2500	2431	2330
28			2312	2244	2149
30			2145	2081	1993
32				1940	1857
34				1815	1738
36				1705	1631
38					1536
40					1452
42					1375



MRT48 - 4,0t

JIB	18	24	30	36	42
1,4 ▶	17,4	17,0	16,5	16,0	15,4
10	4000	4000	4000	4000	4000
12	4000	4000	4000	4000	4000
14	4000	4000	4000	4000	4000
16	4000	4000	4000	4000	3933
18	3850	3820	3721	3616	3465
20		3412	3323	3227	3093
22		3080	2999	2500	2500
24		2805	2731	2500	2500
26			2504	2431	2330
28			2312	2244	2149
30			2145	2081	1993
32				1940	1857
34				1815	1738
36				1705	1631
38					1536
40					1452
42					1375

**ULTRALIFT** If the crane is not equipped with Ultralift control, all intermediate loads are decreased by 10% / Senza il sistema Ultralift tutte le portate intermedie diminuiscono il carico del 10% / Les charges intermediaires sont diminuées de 10% si la grue n'est pas équipé d'un controle Ultralift. / Mit dem ULTRALIFT-System erhöhen alle Zwischenbelastbarkeiten die Last um 10% / Без ULTRALI FT промежуточный вес уменьшается на 10%.

A 1,1 m L = 3,2 m   
 B 1,1 m L = 3,2 m   
 E 1,1 m L = 3,2 m   
 D 1,1 m

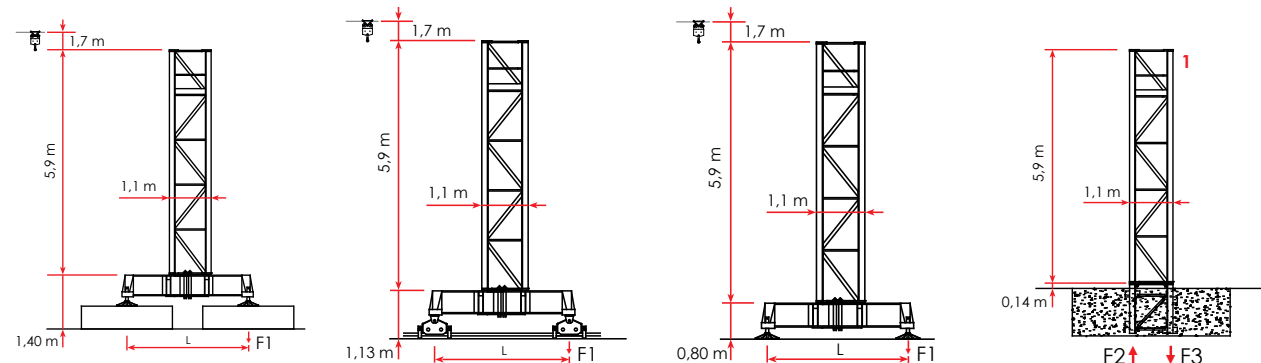

<b>A</b>	Base on concrete pads	Base su zatteroni	Grue sur blocs d'appui	Kran auf Stützblöcken	Кран на опорных блоках
<b>B</b>	Travelling base	Base traslante	Grue à traslation	Fahrbarer Kran	Кран передвижной
<b>E</b>	Base on steel pads	Base con piedi regolabili	Grue sur pieds réglables	Kran auf verstellbaren Füßen	Кран на регулируемых лапах
<b>D</b>	Crane on embedded	Gru su tronchetto	Grue sur plinthe	Kran auf Fundamentplatte	Кран на фундаменте

**A** 1,1 m - L = 3,2 m

EN 14439 - C25					EN 14439 - D25					FEM 1.001				
$\Delta H$ (m)	H (m)	Z** (t)	F1 (kN)		$\Delta H$ (m)	H (m)	Z** (t)	F1 (kN)		$\Delta H$ (m)	H (m)	Z** (t)	F1 (kN)	
7	-	-	-	-	7	-	-	-	-	7	-	-	-	-
6	-	-	-	-	6	-	-	-	-	6	-	-	-	-
5	5,9 m	36,1	65,4	530	5	2,36 m	32,6	75,4	603	5	5,9 m	36,1	60,4	562
4	5,9 m	30,2	55,3	360	4	5,9 m	30,2	65,2	491	4	5,9 m	30,2	45,2	381
3	5,9 m	24,3	45,2	309	3	5,9 m	24,3	55,2	339	3	5,9 m	24,3	40,2	319
2	5,9 m	18,4	45,2	288	2	5,9 m	18,4	50,2	301	2	5,9 m	18,4	40,2	285
+1	5,9 m	12,5	40,2	258	+1	5,9 m	12,5	45,2	275	+1	5,9 m	12,5	40,2	257

**B** 1,1 m - L = 3,2 m STANDARD 1,1 CITY 2,5t

EN 14439 - C25					EN 14439 - D25					FEM 1.001				
$\Delta H$ (m)	H (m)	Z** (t)	F1 (kN)		$\Delta H$ (m)	H (m)	Z** (t)	F1 (kN)		$\Delta H$ (m)	H (m)	Z** (t)	F1 (kN)	
7	-	-	-	-	7	-	-	-	-	7	-	-	-	-
6	-	-	-	-	6	-	-	-	-	6	-	-	-	-
5	5,9 m	35,7	65,7	533	5	2,36 m	32,2	75,7	605	5	5,9 m	35,7	60,6	538
4	5,9 m	29,8	55,5	363	4	5,9 m	29,8	65,5	493	4	5,9 m	29,8	45,5	362
3	5,9 m	23,9	45,5	312	3	5,9 m	23,9	55,5	341	3	5,9 m	23,9	40,4	314
2	5,9 m	18,0	45,4	292	2	5,9 m	18,0	50,5	307	2	5,9 m	18,0	35,4	279
+1	5,9 m	12,1	40,4	262	+1	5,9 m	12,1	45,5	277	+1	5,9 m	12,1	35,4	251

**E** 1,1 m - L = 3,2 m

EN 14439 - C25					EN 14439 - D25					FEM 1.001				
$\Delta H$ (m)	H (m)	Z** (t)	F1 (kN)		$\Delta H$ (m)	H (m)	Z** (t)	F1 (kN)		$\Delta H$ (m)	H (m)	Z** (t)	F1 (kN)	
7	-	-	-	-	7	-	-	-	-	7	-	-	-	-
6	-	-	-	-	6	-	-	-	-	6	-	-	-	-
5	5,9 m	35,5	65,7	518	5	2,36 m	32,0	75,7	593	5	5,9 m	35,5	60,6	546
4	5,9 m	29,6	55,5	359	4	5,9 m	29,6	65,5	483	4	5,9 m	29,6	45,5	368
3	5,9 m	23,7	45,5	308	3	5,9 m	23,7	55,5	334	3	5,9 m	23,7	40,4	316
2	5,9 m	17,8	45,4	288	2	5,9 m	17,8	50,5	301	2	5,9 m	17,8	35,4	280
+1	5,9 m	11,9	40,4	258	+1	5,9 m	11,9	45,5	271	+1	5,9 m	11,9	35,4	252

**Z\*\***  Comply with the specified ballast Z(t) / Attenersi alla zavorra indicata Z(t) / S'en tenir au lest indiqué Z(t) / Unbedingt die angegebenen Ballastwerte einhalten Z(t) / Соблюдать указанный балласт Z(t)

**D** 1,1 m STANDARD 1,1 CITY 2,5t

EN 14439 - C25 EN 14439 - D25 FEM 1.001

$\Delta H$ (m)	H* (m)	F2 (kN)	F3 (kN)	$\Delta H$ (m)	H* (m)	F2 (kN)	F3 (kN)	$\Delta H$ (m)	H* (m)	F2 (kN)	F3 (kN)
7	-	-	-	7	-	-	-	7	-	-	-
6	-	-	-	6	-	-	-	6	-	-	-
5	5,9 m	34,8	913	5	2,36 m	31,3	1010	5	5,9 m	34,8	960
4	5,9 m	28,9	642	4	5,9 m	28,9	823	4	5,9 m	28,9	693
3	5,9 m	23,0	563	3	5,9 m	23,0	563	3	5,9 m	23,0	609
2	5,9 m	17,1	498	2	5,9 m	17,1	498	2	5,9 m	17,1	543
+1	5,9 m	11,2	447	+1	5,9 m	11,2	447	+1	5,9 m	11,2	493

H\*  Climbing cage connection frame including / Telaio di raccordo a spinta incluso / Elément de telescopage compris / Включая соединительную раму подъемной клетки

1,2 m L = 3,8 m **A** 1,2 m L = 3,8 m **B** 1,2 m L = 3,8 m **E** 1,2 m **D**

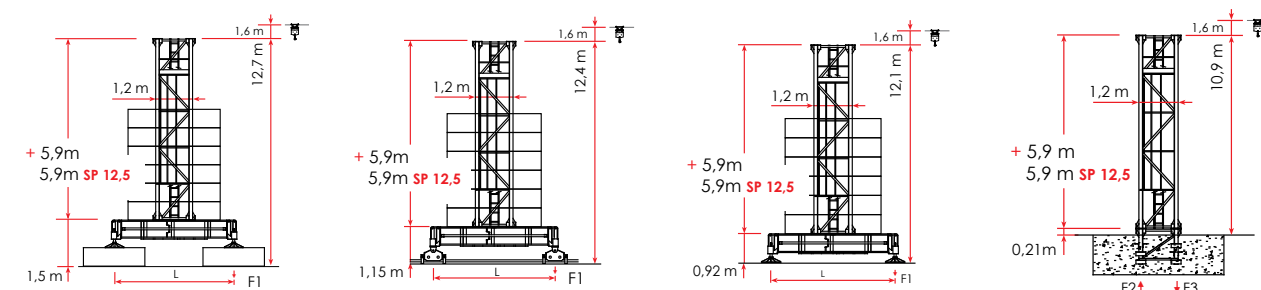

**A** Base on concrete pads / Base su zatteroni / Grue sur blocs d'appui / Kran auf Stützblöcken / Кран на опорных блоках  
**B** Travelling base / Base traslante / Grue à traslation / Fahrbarer Kran / Кран передвижной  
**E** Base on steel pads / Base con piedi regolabili / Grue sur pieds réglables / Kran auf verstellbaren Füßen / Кран на регулируемых лапах  
**D** Crane on embedded / Gru su tronchetto / Grue sur plinthe / Kran auf Fundamentplatte / Кран на фундаменте



**A** 1,2 m - L = 3,8 m



EN 14439 - C25 EN 14439 - D25 FEM 1.001

$\Delta H$ (m)	H (m)	Z** (t)	F1 (kN)	$\Delta H$ (m)	H (m)	Z** (t)	F1 (kN)	$\Delta H$ (m)	H (m)	Z** (t)	F1 (kN)
-	-	-	-	-	-	-	-	-	-	-	-
5	5,9	42,2	79,2	5	5,9	42,2	69,3	5	5,9	42,2	595
4	5,9	36,3	59,4	4	5,9	36,3	58,9	4	5,9	36,3	420
3	5,9	30,4	49,5	3	5,9	30,4	39,8	3	5,9	30,4	298
2	5,9	24,5	39,6	2	5,9	24,5	27,6	2	5,9	24,5	277
+1	5,9	18,6	39,6	+1	5,9	18,6	25,9	+1	5,9	18,6	259





## STANDARD 1,2 CITY 2,5t

B					1,2 m - L = 3,8 m									
														
$\Delta H$ (m)	H (m)	Z** (t)	F1 (kN)		$\Delta H$ (m)	H (m)	Z** (t)	F1 (kN)		$\Delta H$ (m)	H (m)	Z** (t)	F1 (kN)	
-	-	-	-	-	-	-	-	-	-	7	-	-	-	-
-	-	-	-	-	-	-	-	-	-	6	-	-	-	-
5	5,9	41,9	79,3	597	-	-	-	-	-	5	5,9	41,9	79,3	588
4	5,9	36,0	59,4	420	4	5,9	36,0	79,3	584	4	5,9	36,0	59,4	420
3	5,9	30,1	49,5	322	3	5,9	30,1	49,5	387	3	5,9	30,1	39,6	296
2	5,9	24,2	39,6	276	2	5,9	24,2	39,6	276	2	5,9	24,2	39,6	276
+1	5,9	18,3	39,6	259	+1	5,9	18,3	39,6	259	+1	5,9	18,3	39,6	258

E					1,2 m - L = 3,8 m									
														
$\Delta H$ (m)	H (m)	Z** (t)	F1 (kN)		$\Delta H$ (m)	H (m)	Z** (t)	F1 (kN)		$\Delta H$ (m)	H (m)	Z** (t)	F1 (kN)	
7	-	-	-	-	7	-	-	-	-	7	-	-	-	-
6	-	-	-	-	6	-	-	-	-	6	-	-	-	-
5	5,9	41,6	79,3	597	5	-	-	-	-	5	5,9	41,6	79,3	588
4	5,9	35,7	59,4	420	4	5,9	35,7	79,3	584	4	5,9	35,7	59,4	420
3	5,9	29,8	49,5	322	3	5,9	29,8	49,5	387	3	5,9	29,8	39,6	296
2	5,9	23,9	39,6	276	2	5,9	23,9	39,6	276	2	5,9	23,9	39,6	276
+1	5,9	18,0	39,6	259	+1	5,9	18,0	39,6	259	+1	5,9	18,0	39,6	258

**Z\*\***  **Comply with the specified ballast Z(t) / Attenersi alla zavorra indicata Z(t) / S'en tenir au lest indiqué Z(t) / Unbedingt die angegebenen Ballastwerte einhalten Z(t) / Соблюдать указанный балласт Z(t)**

## STANDARD 1,2 CITY 2,5t

D					1,2 m									
														
$\Delta H$ (m)	H* (m)	F2 (kN)	F3 (kN)		$\Delta H$ (m)	H* (m)	F2 (kN)	F3 (kN)		$\Delta H$ (m)	H* (m)	F2 (kN)	F3 (kN)	
7	-	-	-	-	7	-	-	-	-	7	-	-	-	-
6	3,0 m	34,7	719	631	6	-	-	-	-	6	3,0 m	34,7	647	568
5	3,0 m	31,7	586	505	5	3,0 m	31,7	804	719	5	3,0 m	31,7	527	454
4	3,0 m	28,7	519	423	4	3,0 m	28,7	647	571	4	3,0 m	28,7	467	381
3	3,0 m	25,7	487	395	3	3,0 m	25,7	510	438	3	3,0 m	25,7	438	356
2	5,9 m	22,7	458	370	2	5,9 m	22,7	458	370	2	5,9 m	22,7	412	333
+1	5,9 m	16,8	408	327	+1	5,9 m	16,8	408	327	+1	5,9 m	16,8	368	294

**H\***  **Climbing cage connection frame including / Telaio di raccordo a spinta incluso / Elément de telescopage compris / Включая соединительную раму подъемной клетки**

 3 x 13,60 m **MRT48 \_Jib 42 m • HUH 35,4 m**  
**Top part / Parte rotante / Partie tournante / Drehender Kranteil / Поворотная часть**

 1 x 40 High cube **Included counter weight and cabin / Cabina e contrappesi inclusi / Cabine et contrepoids inclus / Kabine und Gegengewichts Blöcke – inbegriffen / Противовес включен – кабина**  
1 x 40 Box  
1 x 40 Open Top

For different heights contact the technical department / Per altezze diverse contattare l'ufficio tecnico / Pour des hauteurs différentes contact le département technique / Für unterschiedliche Höhen Kontakt zum Technischen / Недопустимо увеличение высоты крана без согласования с технической службой производителя

Position of next anchor to increase height under hook / Posizione prossimo ancoraggio per aumento altezza sotto gancio / Position du prochain ancrage pour augmenter la hauteur sous crochet / Lage nächste Verankerung zur Erhöhung unter dem Haken / положение для следующего якоря большей высоты под крюком

Anchor position / Posizione d'ancoraggio / Position de ancrage / Verankerungsposition / позицию анкеровки

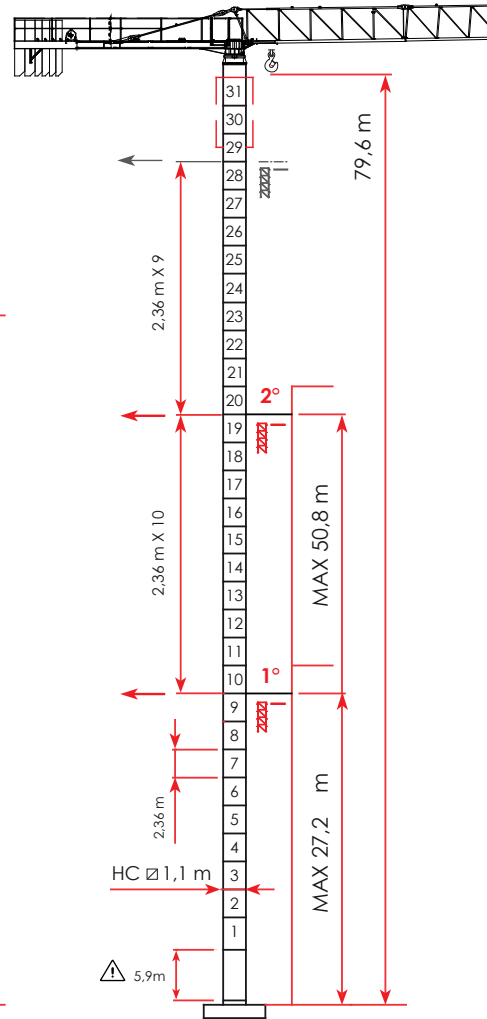

FEM 1.001

EN 14439 C25

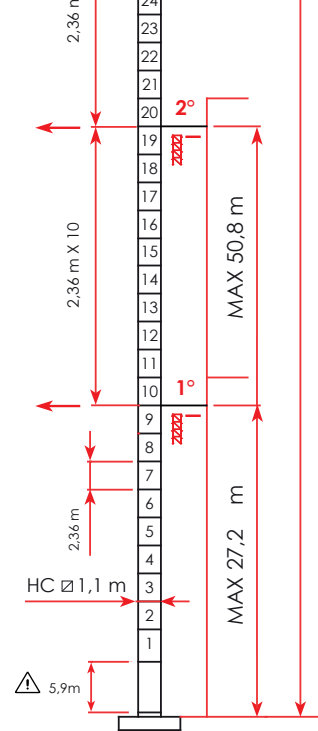
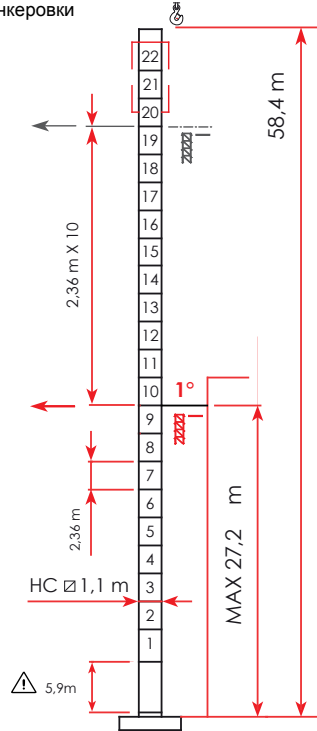
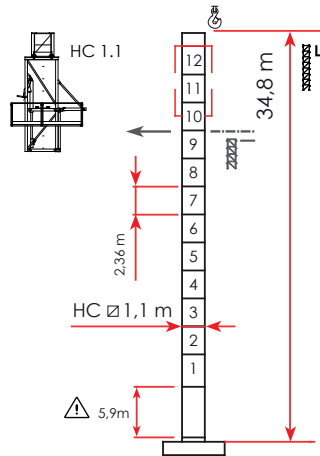

Climbing crane / Sopralzo idraulico / Télésopage sur dalles / Kletterkrane im Gebäude / Кран поднимающийся на плитах перекрытия

Description

Item











Pz

Drawing

Dimension ( m )

Weight ( kg )

n. n° l w h Unit Total

1	1				8,110	1,100	1,700	891	-
2	2				6,040	0,900	1,640	450	-
3	3				6,040	0,900	1,640	441	-
4	4				6,040	0,900	1,640	374	-
5	5				5,990	0,900	1,620	351	-
6	6				5,970	0,900	1,070	353	-
7	7				5,970	0,900	1,030	228	-

Jib element

Elemento freccia

Élément de flèche

Auslegerelement jib section









Секция стрелы

Counterjib - tournable, hoisting winch, trolley jib, electrical box, terminal element / Controfreccia - girevole, argano sollevamento, quadro elettrico, carrello freccia, portablocchi / Contreflèche tournante, treuil de levage, chariot de flèche, armoire électrique, élément terminal / Gegenausleger, Hubwinde, Laufkatze, Schaltschrank, Element für Gegengewichts Blöcke anführen / Консоль с поворотным кругом, лебедка, тележка, эл. ящик, противовесная консоль

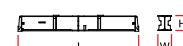
2 1   11,970 1,630 2,100 4,500

Counterweight block / Blocchi di contrappeso / Contre - poids / Gegengewichts Blöcke / Блоки противовеса

3 1   **A45+3**  
0,870 0,470 2,500 1704 3408  
**B45+3**  
0,870 0,335 2,500 1240 2480  
**C45+3**  
0,870 0,290 2,500 1082 2164

Description	Item	Pz	Drawing	Dimension ( m )			Weight ( kg )	
				n.	n°	l	w	h
<b>Tower element</b> / Elementi di torre / Elément de mature / Turmstück / Башенные секции	4	5		2,360	1,100	1,100	595	-
				5,900	1,100	1,100	1280	-
				11,800	1,100	1,100	2400	-
<b>Expendable foundation element</b> / Tronchetto di fondazione / Elément a sceller / Fundamentanker / Анкер	1			1,290	1,320	1,320	520	-
<b>Base main beam</b> / Trave principale cro- ciera di base / Poutre de chassis de base / Haupt-träger für Kreuzbase / Главная балка крестовины основания	5	1		4,870	0,670	0,500	1024	-
<b>Half base beam</b> / Semitrave di base / Semipoutre de chassis de base / Halb-träg- er für Kreuzbase / Полубалка основания	6	2		2,350	0,450	0,540	450	900
<b>Concrete pad</b> / Blocco di appoggio / Sabot en béton / Beton Fuß / Опорный блок	7	1		<b>B1</b> 3,000	0,600	0,600	2465	9860
<b>Driving bogie</b> / Bilancino di traslazione folle/ Boggie fou / Schaukel Bewegung - Neutralstellung / Не приводной балансир	8	9		0,800	0,195	0,385	190	380
				0,925	0,425	0,385	310	620
<b>Driven bogie</b> / Bilancino di traslazione motorizzato / Boggie motorisée / Schau- kel Bewegung - Betriebene / Приводной балансир	10	1		<b>C</b> 3,000	1,200	0,610	5050	-
				<b>C1</b> 3,000	1,200	0,305	2525	-



The Raimondi SL20-TC  
crane elevator





The Raimondi MRT84 at work in Winchester City erected by Bennetts Tower Cranes at a 30 meter tower height with a 30 meter jib length and five tonne maximum capacity



## RAIMONDI<sup>®</sup> MRT84

SINCE 1863

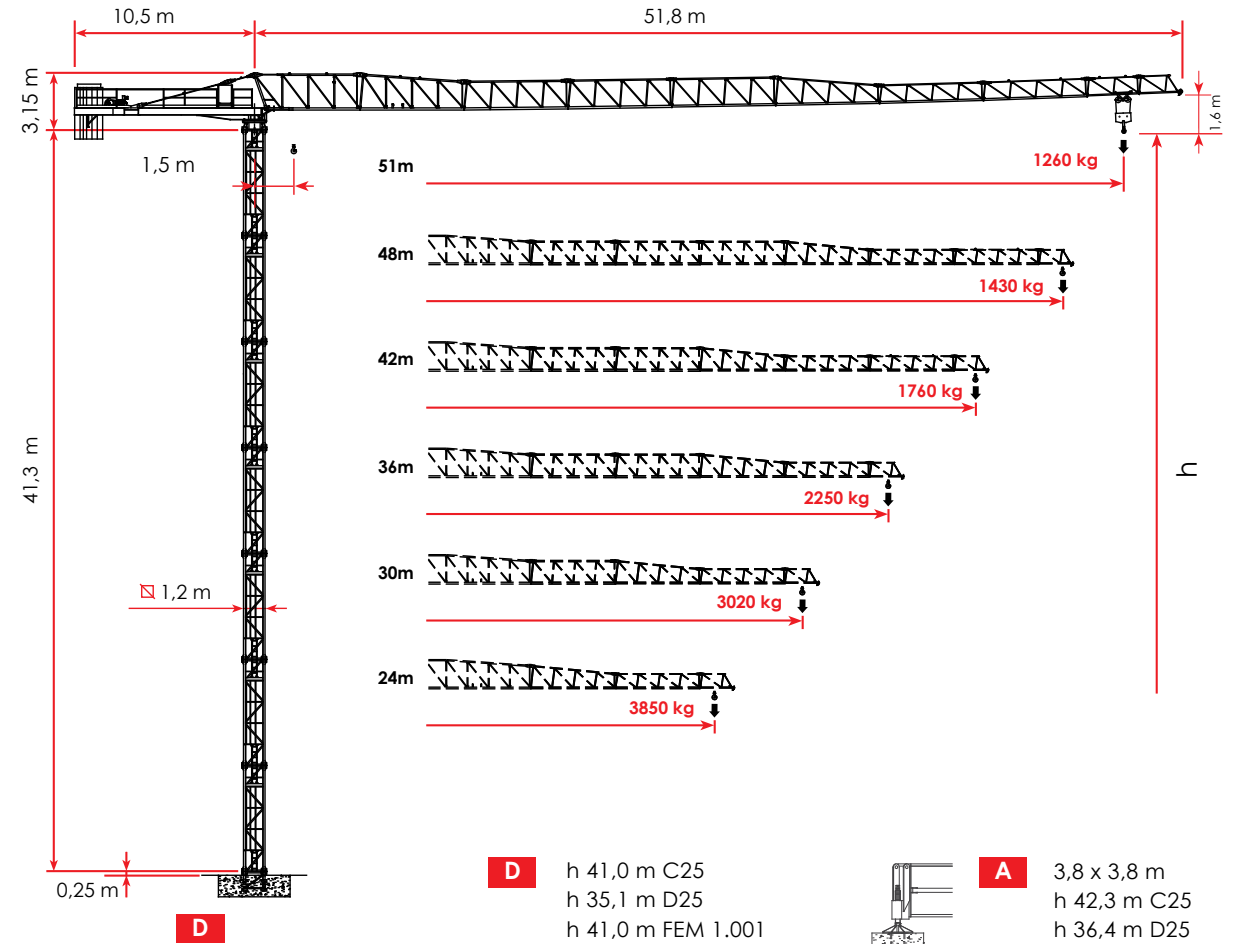

**D** h 41,0 m C25  
h 35,1 m D25  
h 41,0 m FEM 1.001

**A** 3,8 x 3,8 m  
h 42,3 m C25  
h 36,4 m D25  
h 42,3 m FEM 1.001

**B** 3,8 x 3,8 m  
h 42,0 m C25  
h 36,1 m D25  
h 42,0 m FEM 1.001







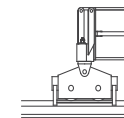







**E** 3,8 x 3,8 m  
h 41,7 m C25  
h 35,8 m D25  
h 41,7 m FEM 1.001







A4 EN 14439 C25 D25 - FEM 1.001



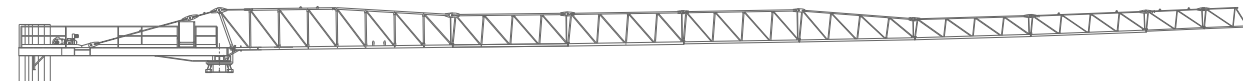





IT	EN	F	DE	RU
 Altezza sotto gancio	Height under hook	Hauteur sous crochet	Höhe unter dem Haken	Высота под крюком
 Contrappesi	Counter weight jib ballast	Lest de contre-flèche	Gegenauslegerballast	Противовесы
 Freccia	Jib	Flèche	Kranarm	стрела крана
 Carico massimo	Max load	Charge maximale	Maximale Belastung	максимальная нагрузка
 Curva di carico Ultralift	Load diagrams with ultralift control	Courbes de charges Ultralift	Lastkurven Ultralift	Кривой Груз Ultralift
 Altezza libera	Free Standing	Hauteur libre	Freistehend	Свободностоящая высота
 Azionamenti	Mechanisms	Mécanismes	Antriebe	Приводы
 Velocità	Speed	Vitesse	Geschwindigkeit	скорость
<b>4* - 5*</b>  Marce con velocità proporzionale al carico	5 step with speed proportional to the load	5 rapports avec une vitesse proportionnelle à la charge	5 Gang Geschwindigkeit proportional zum Last	Автоматический выбор скорости механизма подъема в зависимости от величины груза
 Tiro a 2 funi	Two - rope pull	Tir à deux câbles	Zug an zwei Seilen	Двукратная запасовка тросов
 Tiro a 4 funi	Four - rope pull	Tir à quatre câbles	Zug an vier Seilen	Четырехкратная запасовка тросов
 Totale metri fune tamburo	Total meters rope drum	Total des mètres de corde du tambour	Total Meter Seil Trommel	Запас троса на барабане в метрах
 Diametro fune	Rope diameter	Diamètre du câble	Seildurchmesser	Диаметр троса
 Rotazione	Slewing	Orientation	Schwenken	Поворот
 Carrello	Trolley	Chariot	Katzfahren	Тележка





			MAX 	24 m	30 m	36 m	42 m	48 m	51 m
kg	m	2,5 t							
12050	<b>51</b>	30,0	2500	2473	2020	1699	1459	<b>1375</b>	
11460	<b>48</b>	30,1	2500	2500	2081	1740	<b>1485</b>		
9256	<b>42</b>	31,0	2500	2500	2104	<b>1760</b>			
7934	<b>36</b>	33,0	2500	2500	<b>2310</b>				
6612	<b>30</b>	30,0	2500	<b>2500</b>					
5730	<b>24</b>	24,0	<b>2500</b>						

 400 V ± 5% 50 Hz    2000 / 14 / CE

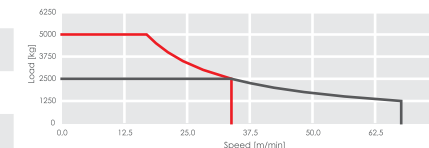
	STEP				
		m/min	kg	m/min	kg
 240 m	1	7,6	2500	3,8	5000
 50 kVA	2	23	2500	11,5	5000
 Ø 11 mm	3	38	2500	19	5000
	4	61	1250	30,5	2500
	5	76	850	38	1700
	<b>5*</b>	91	400	45,5	800





\* **Speed automatically controlled by a current sensor** / Velocità regolata automaticamente da sensore di corrente / Vitesse réglée automatiquement par capteur de courant / Automatisch durch Stromsensor geregelte Geschwindigkeit / **СКОРОСТЬ АВТОМАТИЧЕСКИ КОНТРОЛИРУЕТСЯ ДАТЧИКОМ НАПРЯЖЕНИЯ**

 0,37/ 0,7/ 1,0 min<sup>-1</sup> • 4 kW /  14,0/ 39,0/ 63,0/ 79,0 (1) m/min • 3,6 kW /  14 m/min • 2 x 2,9 kW



MRT84 - 2,5 / 5,0t

JIB	24	30	36	42	48	51
1,5 ▶	<b>18,5</b>	<b>18,0</b>	<b>17,0</b>	<b>16,0</b>	<b>16,0</b>	<b>14,0</b>
14	5000	5000	5000	5000	5000	5000
16	5000	5000	5000	5000	5000	4810
18	5000	5000	4893	4606	4416	4221
20	4706	4735	4357	4099	3929	3754
22	4238	4263	3920	3687	3533	3374
<b>24</b>	<b>3850</b>	3873	3559	3346	3205	3060
28		3263	2995	2813	2692	2569
<b>30</b>		<b>3020</b>	2771	2601	2489	2373
32			2575	2416	2311	2203
34			2403	2253	2155	2053
<b>36</b>			<b>2250</b>	2109	2016	1920
40				1865	1781	1695
<b>42</b>				<b>1760</b>	1680	1599
44					1589	1511
46					1506	1432
<b>48</b>	+ 50 kg				<b>1430</b>	1359
<b>51</b>						<b>1260</b>

**ULTRALIFT** If the crane is not equipped with Ultralift control, all intermediate loads are decreased by 10% / Senza il sistema Ultralift tutte le portate intermedie diminuiscono il carico del 10% / Les charges intermediaires sont diminuees de 10% si la grue n'est pas équipé d'un controle Ultralift. / Mit dem ULTRALIFT-System erhöhen alle Zwischenbelastbarkeiten die Last um 10% / Без ULTRALIFT промежуточный вес уменьшается на 10%.

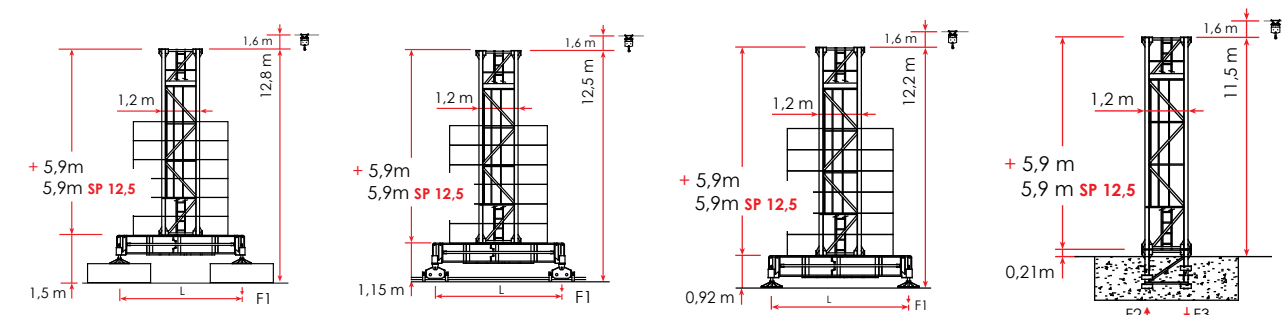



<b>A</b>	Base on concrete pads	Base su zatteroni	Grue sur blocs d'appui	Kran auf Stützblöcken	Кран на опорных блоках
<b>B</b>	Travelling base	Base traslante	Grue à traslation	Fahrbarer Kran	Кран передвижной
<b>E</b>	Base on steel pads	Base con piedi regolabili	Grue sur pieds réglables	Kran auf verstellbaren Füßen	Кран на регулируемых лапах
<b>D</b>	Crane on embedded	Gru su fronchetto	Grue sur plinthe	Kran auf Fundamentplatte	Кран на фундаменте







EN 14439 - C25					EN 14439 - D25					FEM 1.001				
$\Delta H$ (m)	H (m)	Z** (t)	F1 (kN)		$\Delta H$ (m)	H (m)	Z** (t)	F1 (kN)		$\Delta H$ (m)	H (m)	Z** (t)	F1 (kN)	
7	-	-	-	-	7	-	-	-	-	7	-	-	-	-
6	-	-	-	-	6	-	-	-	-	6	-	-	-	-
5	5,9	42,3	89,1	737	5	-	-	-	-	5	5,9	42,3	59,4	595
4	5,9	36,4	69,3	517	4	5,9	36,4	89,1	731	4	5,9	36,4	49,5	478
3	5,9	30,5	59,4	402	3	5,9	30,5	69,3	489	3	5,9	30,5	49,5	394
2	5,9	24,6	59,4	371	2	5,9	24,6	49,5	354	2	5,9	24,6	39,6	341
+1	5,9	18,7	59,4	350	+1	5,9	18,7	39,6	300	+1	5,9	18,7	39,6	323

**B**  **STANDARD 1,2 CITY 5t**



 EN 14439 - C25					 EN 14439 - D25					 FEM 1.001				
$\Delta H$ (m)	H (m)	Z** (t)	F1 (kN)		$\Delta H$ (m)	H (m)	Z** (t)	F1 (kN)		$\Delta H$ (m)	H (m)	Z** (t)	F1 (kN)	
7	-	-	-	-	7	-	-	-	-	7	-	-	-	-
6	-	-	-	-	6	-	-	-	-	6	-	-	-	-
5	5,9	42,0	89,1	735	5	-	-	-	-	5	5,9	42,0	59,4	576
4	5,9	36,1	69,3	515	4	5,9	36,1	89,2	731	4	5,9	36,1	49,5	461
3	5,9	30,2	49,5	378	3	5,9	30,2	69,3	487	3	5,9	30,2	49,5	386
2	5,9	24,3	39,6	324	2	5,9	24,3	59,4	382	2	5,9	24,3	39,6	337
+1	5,9	18,4	39,6	303	+1	5,9	18,4	59,4	352	+1	5,9	18,4	39,6	321

**E**  **STANDARD 1,2 CITY 5t**



 EN 14439 - C25					 EN 14439 - D25					 FEM 1.001				
$\Delta H$ (m)	H (m)	Z** (t)	F1 (kN)		$\Delta H$ (m)	H (m)	Z** (t)	F1 (kN)		$\Delta H$ (m)	H (m)	Z** (t)	F1 (kN)	
7	-	-	-	-	7	-	-	-	-	7	-	-	-	-
6	-	-	-	-	6	-	-	-	-	6	-	-	-	-
5	5,9	41,7	89,1	719	5	-	-	-	-	5	5,9	41,7	59,4	576
4	5,9	35,8	69,3	502	4	5,9	35,8	89,2	712	4	5,9	35,8	49,5	461
3	5,9	29,9	49,5	370	3	5,9	29,9	69,3	472	3	5,9	29,9	49,5	386
2	5,9	24,0	39,6	320	2	5,9	24,0	49,5	347	2	5,9	24,0	39,6	337
+1	5,9	18,1	39,6	299	+1	5,9	18,1	39,6	299	+1	5,9	18,1	39,6	321

**Z\*\***  **Comply with the specified ballast Z(t) / Attenersi alla zavorra indicata Z(t) / S'en tenir au lest indiqué Z(t) / Unbedingt die angegebenen Ballastwerte einhalten Z(t) / Соблюдать указанный балласт Z(t)**

**D**  **STANDARD 1,2 CITY 5t**

 EN 14439 - C25					 EN 14439 - D25					 FEM 1.001				
$\Delta H$ (m)	H (m)	F2 (kN)	F3 (kN)		$\Delta H$ (m)	H (m)	F2 (kN)	F3 (kN)		$\Delta H$ (m)	H (m)	F2 (kN)	F3 (kN)	
7	-	-	-	-	7	-	-	-	-	7	-	-	-	-
6	-	-	-	-	6	-	-	-	-	6	-	-	-	-
5	5,9	41,0	1278	1122	5	-	-	-	-	5	5,9	41,0	1023	864
4	5,9	35,1	909	759	4	5,9	35,1	1239	1089	4	5,9	35,1	733	577
3	5,9	29,2	642	508	3	5,9	29,2	844	701	3	5,9	29,2	607	479
2	5,9	23,3	568	440	2	5,9	23,3	568	440	2	5,9	23,3	543	422
+1	5,9	17,4	507	386	+1	5,9	17,4	507	386	+1	5,9	17,4	491	378

**D**  **STANDARD 1,18 HC 5t**

 EN 14439 - C25					 EN 14439 - D25					 FEM 1.001				
$\Delta H$ (m)	H (m)	F2 (kN)	F3 (kN)		$\Delta H$ (m)	H (m)	F2 (kN)	F3 (kN)		$\Delta H$ (m)	H (m)	F2 (kN)	F3 (kN)	
-	-	-	-	-	-	-	-	-	-	-	-	-	-	-
5	2,36	36,1	1241	1063	5	-	-	-	-	5	2,36	36,1	1117	957
4	2,36	33,7	1068	895	4	-	-	-	-	4	2,36	33,7	961	806
3	2,36	31,4	910	741	3	2,36	31,4	1249	1080	3	2,36	31,4	819	667
2	2,36	29,0	766	611	2	2,36	29,0	1059	895	2	2,36	29,0	689	550
+1	2,36	26,6	726	575	+1	2,36	26,6	886	725	+1	2,36	26,6	653	518
n°10	2,36	24,2			n°10	2,36	24,2			n°10	2,36	24,2		

## 1,5 CITY - TP 12/15 - HEM BOOSTER

TP12/15m L = 4,5 m

**E**

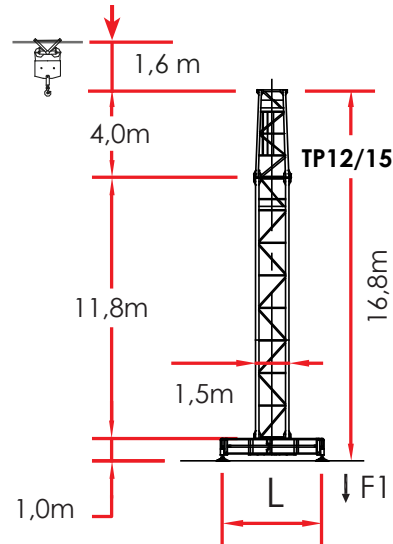

TP12/15m HEM Booster

**D**

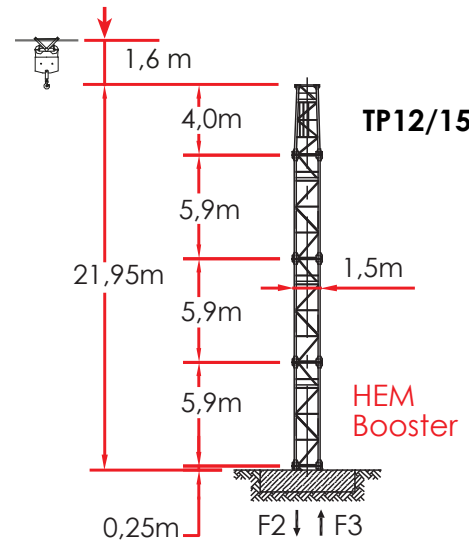

For different heights contact the technical department / Per altezze diverse contattare l'ufficio tecnico / Pour des hauteurs différentes contactez le département technique / Für unterschiedliche Höhen Kontakt zum Technischen / Недопустимо увеличение высоты крана без согласования с технической службой производителя



Position of next anchor to increase height under hook / Posizione prossimo ancoraggio per aumento altezza sotto gancio / Position du prochain ancrage pour augmenter la hauteur sous crochet / Lage nächste Verankerung zur Erhöhung unter dem Haken / положение для следующего якоря большей высоты под крюком



Anchor position / Posizione d'ancoraggio / Position de ancrage / Verankerungsposition / позицию анкеровки



FEM 1.001

EN 14439 C25

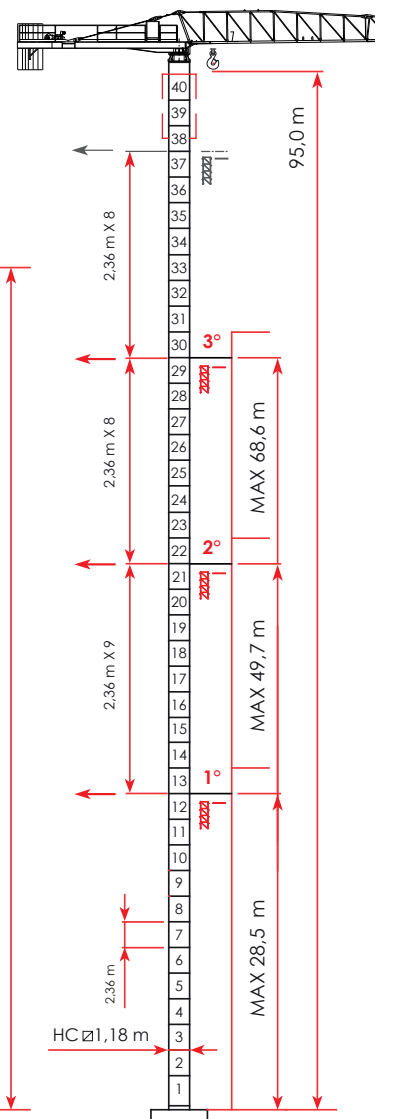
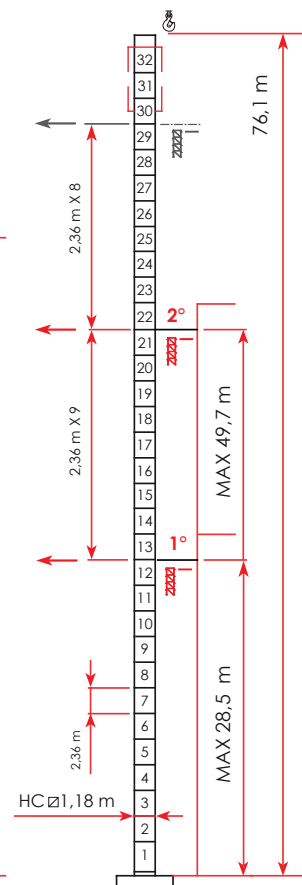
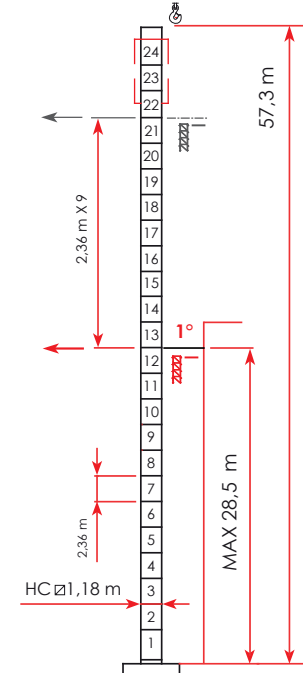
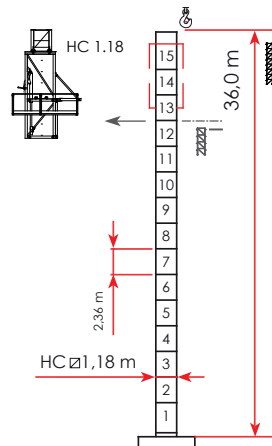

Climbing crane / Sopralzo idraulico / Télécopage sur dalles / Kletterkrane im Gebäude / Кран поднимающийся на плитах перекрытия











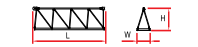



**E** 1,2/1,5 m - L = 4,5 m

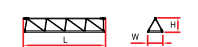

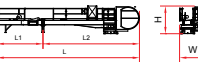









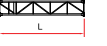

	$\Delta H$ (m)	H (m)	Z** (t)	F1 (kN)
-	-	-	-	-
6	5,9	51,7	82,6	910
5	5,9			
4	5,9			
3	5,9			
2	5,9			
+1	5,9			

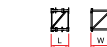

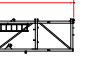
**D** 1,2/1,5 m HEM Booster

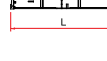
	$\Delta H$ (m)	H (m)	F2 (kN)	F3 (kN)
-	-	-	-	-
6	5,9	56,9	1614	1424
5	5,9			
4	5,9			
3	5,9			
2	5,9			
+1	5,9			

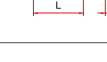

Description	Item	Pz	Drawing	Dimension ( m )			Weight ( kg )	
				n.	n°	l	w	h
<b>Jib element</b> Elemento freccia Elément de flèche Auslegerelement jib section Секция стрелы	1A			6,170	1,100	2,130	960	-
	1B			6,090	1,100	2,100	740	-
	2			6,070	1,100	1,700	670	-
	3			6,070	1,100	1,700	500	-
	4			6,010	1,100	1,700	450	-
	5			6,010	1,100	1,700	380	-
	6			5,980	1,100	1,100	370	-
	7			5,980	1,100	1,100	320	-
	8			3,070	1,100	1,100	130	-
<b>Counterjib - tournable, hoisting winch, trolley jib, electrical box</b> / Controfreccia - girevole, organo sollevamento, quadro elettrico / Contreflèche tournante, treuil de levage, armoire électrique / Gegenausleger, Hubwinde, Laufkatze, Schaltschrank, Element für Gegengewichts Blöcke anführen / Консоль с поворотным кругом, лебедка, тележка	1			L1 4,10 L2 7,87	1,760 7,870	2,450 2,400	2130 2,450	3670
	2			L 11,97	2,400	2,450	5800	-
	1			3,280	1,580	2,210	890	-
<b>Counterweight block</b> / Blocchi di contrappeso / Contre - poids / Gegengewichts Blöcke / Блоки противовеса	4			A75 1,250	0,300	2,865	2204	8816
	2			B75 1,250	0,180	2,865	1322	2644
	1			D93 0,900	0,200	1,450	590	-

Description	Item	Pz	Drawing	Dimension ( m )			Weight ( kg )	
				n.	n°	l	w	h
<b>Tower element</b> / Elementi di torre / Elément de mature / Turmstück / Башенные секции	1			City 1,20 2,950	1,200	1,380	815	-
				HC1,18 2,360	1,180	1,180	870	-
				City 1,20 5,900	1,200	1,380	1610	-
				HC1,18 5,900	1,180	1,180	1850	-
	4			City 1,20 11,800	1,200	1,380	2600	-
			HC 1,18 11,800	1,180	1,180	3350	-	
<b>Expendable foundation element</b> / Tronchetto di fondazione / Elément a sceller / Fundamentanker / Анкер	5			City 1,20 1,090	1,200	1,380	476	-
				HC 1,18 1,350	1,490	1,490	790	-
<b>Climbing Cage</b> / Gabbia di montaggio / Semipoutre de chassis de base / Montagekäfig	6			HC 1,18 4,800	1,680	1,830	3000	-
				CITY 1,20 3,8 x 3,8 m				-
<b>Base main beam</b> / Trave principale crosiera di base / Poutre de chassis de base / Haupt-träger für Kreuzbase / Главная балка крестовины основания	7			5,720	0,670	0,650	1560	-
				2,770	0,450	0,665	750	1500
<b>Half base beam</b> / Semitrave di base / Semipoutre de chassis de base / Halb-träger für Kreuzbase / Полубалка основания	8			2,770	0,450	0,665	750	1500
				3,000	0,600	0,600	2464	-
<b>Concrete pad</b> / Blocco di appoggio / Sabot en béton / Beton Fuß / Опорный блок	9			3,000	0,600	0,600	2464	-

Description	Item	Pz	Drawing	Dimension ( m )			Weight ( kg )	
				n.	n°	l	w	h
<b>Driving bogie</b> / Bilancino di traslazione folle / Boggie fou / Schaukel Bewegung - Neutralstellung / Не приводной балансир	<b>10</b>			0,800	0,195	0,385	190	380
<b>Driven bogie</b> / Bilancino di traslazione motorizzato / Boggie motoriseè / Schaukel Bewegung - Betriebene / Приводной балансир	<b>11</b>			0,925	0,425	0,385	310	620
<b>Base ballast block</b> / Blocco di zavorra / Lest de base / Grundballast / блок балласта	<b>12</b>	1		<sup>A</sup> 3,000	1,200	0,600	4953	-



3 x 13,60 m  
1 x 7,00 m

MRT84 \_Jib 51 m • HUH 41,3 m

Top part / Parte rotante / Partie tournante / Drehender Kranteil / Поворотная часть



3 x 40 High cube  
1 x 40 Open Top

Included counter weight and cabin / Cabina e contrappesi inclusi / Cabine et contrepoids incluses / Kabine und Gegengewichts Blöcke – inbegriffen / Противовес включен - кабина



During erection, technicians work with the Deluxe R16 Crane Cabin





Two Raimondi MRT111s erected in Dubai, United Arab Emirates at work at a large scale residential development jobsite

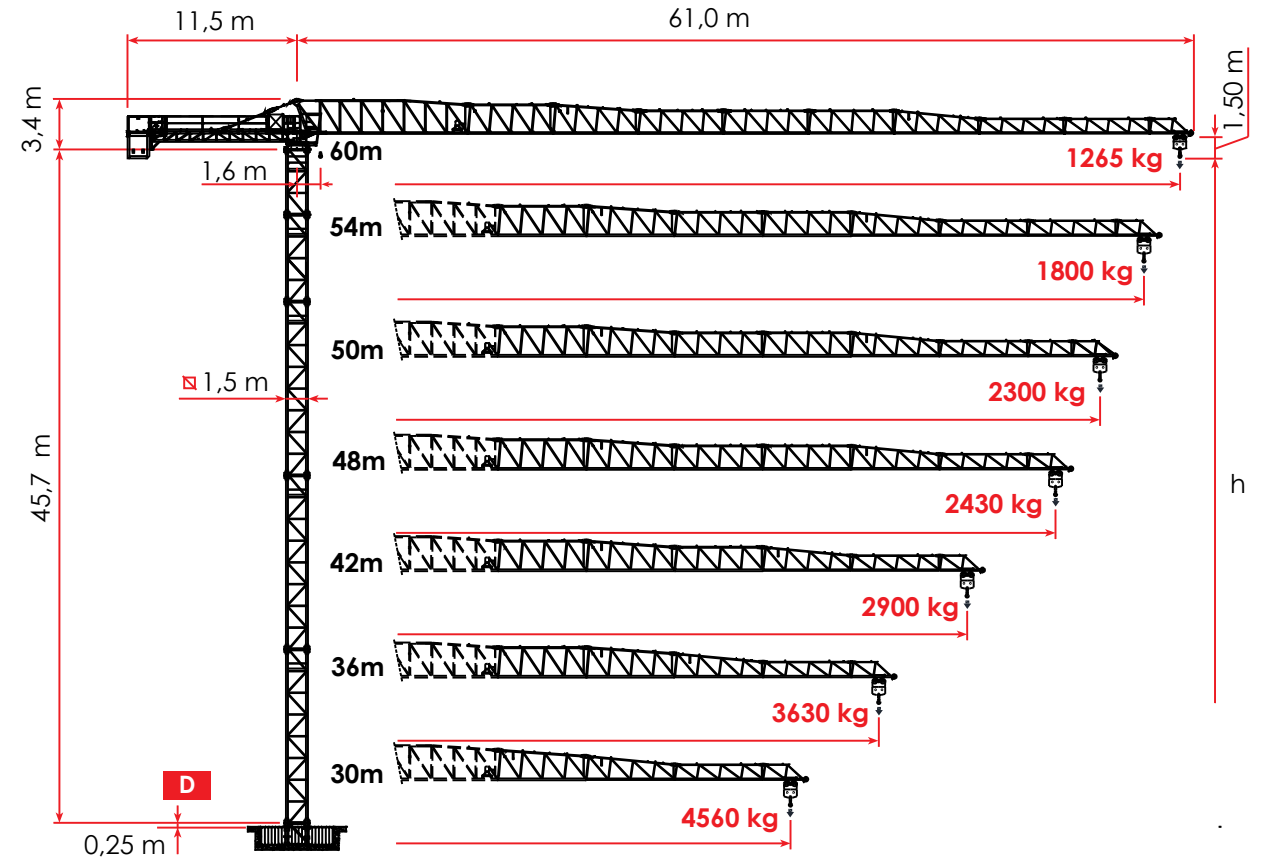



# RAIMONDI<sup>®</sup> MRT111

SINCE 1863



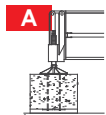

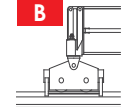



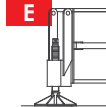





   2000/14/CE  
A4 EN 14439 C25 D25 - FEM 1.001

**D** h 45,5 m EN14439.C25  
h 38,1 m EN14439.D25  
h 45,5 m FEM 1.001

**A**  4,5 x 4,5 m  
h 47,0 m EN14439.C25  
h 39,6 m EN14439.D25  
h 47,0 m FEM 1.001

**B**  4,5 x 4,5 m  
h 46,6 m EN14439.C25  
h 39,2 m EN14439.D25  
h 46,6 m FEM 1.001

**E**  4,5 x 4,5 m  
h 46,4 m EN14439.C25  
h 39,0 m EN14439.D25  
h 46,4 m FEM 1.001

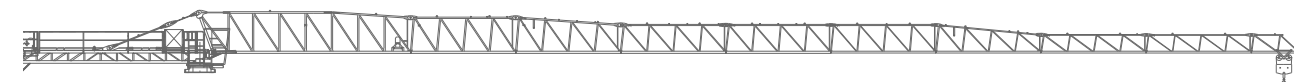

IT	EN	F	DE	RU
 Altezza sotto gancio	Height under hook	Hauteur sous crochet	Höhe unter dem Haken	Высота под крюком
 Contrappesi	Counter weight jib ballast	Lest de contre-flèche	Gegenauslegerballast	Противовесы
 Freccia	Jib	Flèche	Kranarm	стрела крана
 Carico massimo	Max load	Charge maximale	Maximale Belastung	максимальная нагрузка
 Curva di carico Ultralift	Load diagrams with ultralift control	Courbes de charges Ultralift	Lastkurven Ultralift	Кривой Груз Ultralift
 Altezza libera	Free Standing	Hauteur libre	Freistehend	Свободностоящая высота
 Azionamenti	Mechanisms	Mécanismes	Antriebe	Приводы
 Velocità	Speed	Vitesse	Geschwindigkeit	скорость
<b>4* - 5*</b>  Marce con velocità proporzionale al carico	5 step with speed proportional to the load	5 rapports avec une vitesse proportionnelle à la charge	5 Gang Geschwindigkeit proportional zum Last	Автоматический выбор скорости механизма подъема в зависимости от величины груза
 Tiro a 2 funi	Two - rope pull	Tir à deux câbles	Zug an zwei Seilen	Двукратная запасовка тросов
 Tiro a 4 funi	Four - rope pull	Tir à quatre câbles	Zug an vier Seilen	Четырехкратная запасовка тросов
 Totale metri fune tamburo	Total meters rope drum	Total des mètres de corde du tambour	Total Meter Seil Trommel	Запас троса на барабане в метрах
 Diametro fune	Rope diameter	Diamètre du câble	Seildurchmesser	Диаметр троса
 Rotazione	Slewing	Orientation	Schwenken	Поворот
 Carrello	Trolley	Chariot	Katzfahren	Тележка







kg	m	8,0 t	24,0 m	30,0 m	36,0 m	42,0 m	48,0 m	50,0 m	54,0 m	60,0 m
15.260	<b>60</b>	13,0	4090	3137	2508	2061	1728	1635	1470	<b>1265</b>
15.260	<b>54</b>	15,0	4779	3694	2979	2472	2093	1988	<b>1800</b>	
15.260	<b>50</b>	16,8	5440	4220	3416	2845	2419	<b>2300</b>		
13.576	<b>48</b>	16,8	5463	4238	3430	2857	<b>2430</b>			
11.445	<b>42</b>	17,0	5538	4298	3480	<b>2900</b>				
9.314	<b>36</b>	17,5	5614	4358	<b>3630</b>					
7.183	<b>30</b>	18,0	5868	<b>4560</b>						
6.393	<b>24</b>	18,5	<b>5940</b>							

 400 V ± 5% 50 Hz

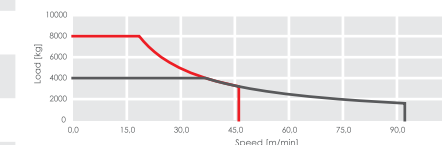
 2000 / 14 / CE

STEP	II		IV		
	m/min	kg	m/min	kg	
 450 m	1	7	4000	3,5	8000
 70 kVA	2	25	4000	12,5	8000
 Ø 12 mm	3	43	4000	21,5	8000
	4	68	2200	34,0	4400
	5	93	1300	46,5	2600
<b>5*</b>	100	600	50,0	1200	

 kVA **Power required** / Potenza richiesta / Puissance requise / Erforderliche Leistung / Потребляемая мощность

 0,23/0,47/0,71 min<sup>-1</sup> • 2 x 4 kW /  14,0/39,0/63,0/ 79,0 (1) m/min • 5,5 kW /  18 m/min • 2 x 2,9 kW

U <sub>lift</sub>	JIB	24	30	36	42	48	50	54	60
		1,6 ▶	<b>17,5</b>	<b>30,0</b>	<b>33,6</b>	<b>33,2</b>	<b>33,0</b>	<b>33,0</b>	<b>33,0</b>
12	4000	4000	4000	4000	4000	4000	4000	4000	4000
14	4000	4000	4000	4000	4000	4000	4000	4000	4000
20	4000	4000	4000	4000	4000	4000	4000	4000	4000
22	4000	4000	4000	4000	4000	4000	4000	4000	4000
<b>24</b>	<b>4000</b>	4000	4000	4000	4000	4000	4000	4000	4000
28		4000	4000	4000	4000	4000	4000	4000	3571
<b>30</b>		<b>4000</b>	4000	4000	4000	4000	4000	3873	3247
32			4000	4000	4000	4000	4000	3597	3010
<b>36</b>			<b>3730</b>	3592	3530	3530	3138	2618	
38				3327	3319	3318	2944	2453	
<b>42</b>				<b>3010</b>	2957	2957	2615	2171	
46					2660	2559	2345	1939	
<b>48</b>					<b>2530</b>	2529	2226	1838	
<b>50</b>						<b>2410</b>	2117	1745	
<b>54</b>							<b>1925</b>	1580	
58								1438	
<b>60</b>								<b>1375</b>	

MRT111 - 4,0t

U <sub>lift</sub>	JIB	24	30	36	42	48	50	54	60
		1,6 ▶	<b>18,5</b>	<b>18,0</b>	<b>17,5</b>	<b>17,0</b>	<b>16,8</b>	<b>16,8</b>	<b>16,8</b>
12	8000	8000	8000	8000	8000	8000	8000	8000	8000
14	8000	8000	8000	8000	8000	8000	8000	8000	7598
20	7289	7192	6885	6794	6703	6676	5877	5056	
22	6551	6467	6190	6107	6025	6000	5276	4527	
<b>24</b>	<b>5940</b>	5868	5614	5538	5463	5440	4779	4090	
28		4932	4715	4651	4587	4567	4003	3407	
<b>30</b>		<b>4560</b>	4358	4298	4238	4220	3694	3137	
32			4047	3991	3935	3918	3425	2900	
<b>36</b>			<b>3630</b>	3480	3430	3416	2979	2508	
38				3266	3219	3205	2792	2343	
<b>42</b>				<b>2900</b>	2857	2845	2472	2061	
46					2560	2548	2208	1829	
<b>48</b>					<b>2430</b>	2419	2093	1728	
<b>50</b>						<b>2300</b>	1988	1635	
<b>54</b>							<b>1800</b>	1470	
58								1329	
<b>60</b>								<b>1265</b>	

MRT111 - 8,0t

**ULTRALIFT** If the crane is not equipped with Ultralift control, all intermediate loads are decreased by 10% / Senza il sistema Ultralift tutte le portate intermedie diminuiscono il carico del 10% / Les charges intermediaires sont diminuees de 10% si la grue n'est pas équipé d'un controle Ultralift. / Mit dem ULTRALIFT-System erhöhen alle Zwischenbelastbarkeiten die Last um 10% / Без ULTRALI FT промежуточный вес уменьшается на 10%.

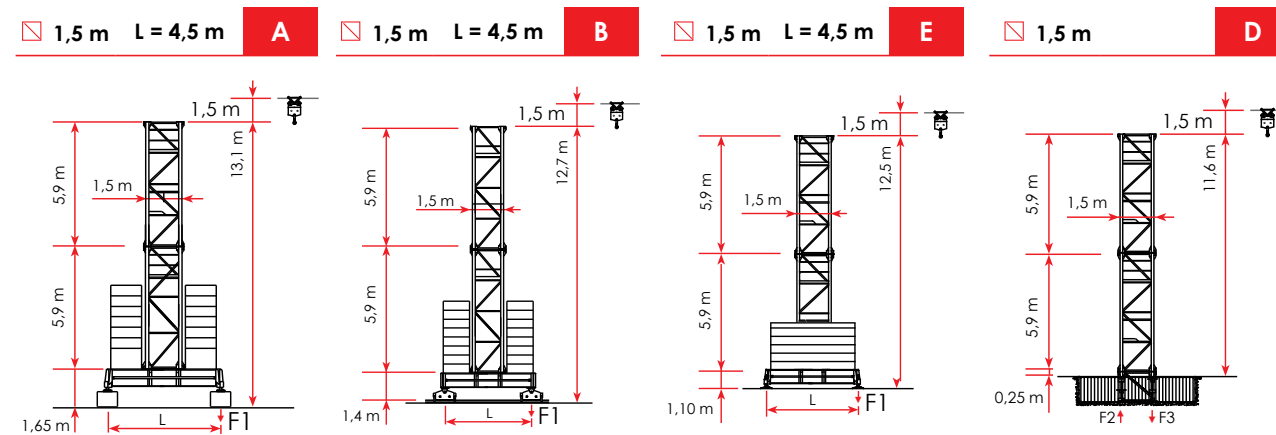

<b>A</b>	Base on concrete pads	Base su zatteroni	Grue sur blocs d'appui	Kran auf Stützblöcken	Кран на опорных блоках
<b>B</b>	Travelling base	Base traslante	Grue à traslation	Fahrbarer Kran	Кран передвижной
<b>E</b>	Base on steel pads	Base con piedi regolabili	Grue sur pieds réglables	Kran auf verstellbaren Füßen	Кран на регулируемых лапах
<b>D</b>	Crane on embedded	Gru su tronchetto	Grue sur plinthe	Kran auf Fundamentplatte	Кран на фундаменте

<b>A</b>		1,5 m - L = 4,5 m						1,5 m - L = 4,5 m						1,5 m - L = 4,5 m			
		EN 14439 - C25						EN 14439 - D25						FEM 1.001			
		$\Delta H$ (m)	H (m)	Z** (t)	F1 (kN)			$\Delta H$ (m)	H (m)	Z** (t)	F1 (kN)			$\Delta H$ (m)	H (m)	Z** (t)	F1 (kN)
7	-	-	-	-	-	7	-	-	-	-	-	7	-	-	-	-	-
6	4,4	47,0	86,5	933		6	-	-	-	-		6	4,4	47,0	80,6	673	
5	5,9	42,6	74,7	700		5	2,95	39,6	80,6	829		5	5,9	42,6	62,9	537	
4	5,9	36,7	57,0	509		4	5,9	36,7	62,9	694		4	5,9	36,7	51,1	457	
3	5,9	30,8	51,1	436		3	5,9	30,8	51,1	487		3	5,9	30,8	45,2	421	
2	5,9	24,9	45,2	396		2	5,9	24,9	45,2	395		2	5,9	24,9	39,3	382	
+1	5,9	19,0	45,2	373		+1	5,9	19,0	45,2	370		+1	5,9	19,0	39,3	351	



**B** 1,5 m - L = 4,5 m **STANDARD 1,5 CITY 8t**

EN 14439 - C25					EN 14439 - D25					FEM 1.001					
$\Delta H$ (m)	H (m)	Z** (t)	F1 (kN)		$\Delta H$ (m)	H (m)	Z** (t)	F1 (kN)		$\Delta H$ (m)	H (m)	Z** (t)	F1 (kN)		
7	-	-	-	-	7	-	-	-	-	7	-	-	-	-	
6	4,4	46,6	88,5	923	6	-	-	-	-	6	4,4	46,6	76,7	641	
5	5,9	42,2	70,8	689	5	2,95	39,2	76,7	816	5	5,9	42,2	59,0	517	
4	5,9	36,3	53,1	499	4	5,9	36,3	64,9	682	4	5,9	36,3	47,2	447	
3	5,9	30,4	47,2	430	3	5,9	30,4	47,2	476	3	5,9	30,4	41,3	400	
2	5,9	24,5	41,3	388	2	5,9	24,5	41,3	386	2	5,9	24,5	35,4	366	
+1	5,9	18,6	41,3	364	+1	5,9	18,6	41,3	365	+1	5,9	18,6	35,4	345	

**E** 1,5 m - L = 4,5 m

EN 14439 - C25					EN 14439 - D25					FEM 1.001					
$\Delta H$ (m)	H (m)	Z** (t)	F1 (kN)		$\Delta H$ (m)	H (m)	Z** (t)	F1 (kN)		$\Delta H$ (m)	H (m)	Z** (t)	F1 (kN)		
7	-	-	-	-	7	-	-	-	-	7	-	-	-	-	
6	4,4	46,4	88,5	914	6	-	-	-	-	6	4,4	46,4	76,7	673	
5	5,9	42,0	70,8	682	5	2,95	39,0	76,7	807	5	5,9	42,0	59,0	516	
4	5,9	36,1	53,1	493	4	5,9	36,1	64,9	674	4	5,9	36,1	47,2	439	
3	5,9	30,2	47,2	425	3	5,9	30,2	47,2	470	3	5,9	30,2	41,3	396	
2	5,9	24,3	41,3	383	2	5,9	24,3	41,3	381	2	5,9	24,3	35,4	354	
+1	5,9	18,4	41,3	359	+1	5,9	18,4	41,3	360	+1	5,9	18,4	35,4	342	

**Z\*\***  Comply with the specified ballast Z(t) / Attenersi alla zavorra indicata Z(t) / S'en tenir au lest indiqué Z(t) / Unbedingt die angegebenen Ballastwerte einhalten Z(t) / Соблюдать указанный балласт Z(t)

**D** 1,5 m **STANDARD 1,5 CITY 8t**

EN 14439 - C25					EN 14439 - D25					FEM 1.001					
$\Delta H$ (m)	H (m)	F2 (kN)	F3 (kN)		$\Delta H$ (m)	H (m)	F2 (kN)	F3 (kN)		$\Delta H$ (m)	H (m)	F2 (kN)	F3 (kN)		
7	-	-	-	-	7	-	-	-	-	7	-	-	-	-	
6	4,4	45,5	1561	1330	6	-	-	-	-	6	4,4	45,5	1328	1091	
5	5,9	41,1	1183	962	5	2,95	38,1	1373	1154	5	5,9	41,1	1013	793	
4	5,9	35,2	865	654	4	5,9	35,2	1159	947	4	5,9	35,2	743	538	
3	5,9	29,3	741	554	3	5,9	29,3	814	612	3	5,9	29,3	724	501	
2	5,9	23,4	673	496	2	5,9	23,4	674	496	2	5,9	23,4	660	446	
+1	5,9	17,5	615	449	+1	5,9	17,5	617	449	+1	5,9	17,5	605	401	

**D** 1,5 m **BOOSTER**

EN 14439 - C25					FEM 1.001					
$\Delta H$ (m)	H (m)	F2 (kN)	F3 (kN)		$\Delta H$ (m)	H (m)	F2 (kN)	F3 (kN)		
8	-	-	-	-	7	2,95	55,8	1782	1553	
7	4,425	52,9	1990	1751	6	5,90	-	-	-	
6	5,90	48,5	1545	1316	5	5,90	-	-	-	
5	5,90	42,6	1169	950	4	5,90	-	-	-	
4	5,90	36,7	852	644	3	5,90	-	-	-	
3	5,90	30,8	737	552	2	5,90	-	-	-	
+2	5,90	24,9	670	495	+1	5,90	-	-	-	

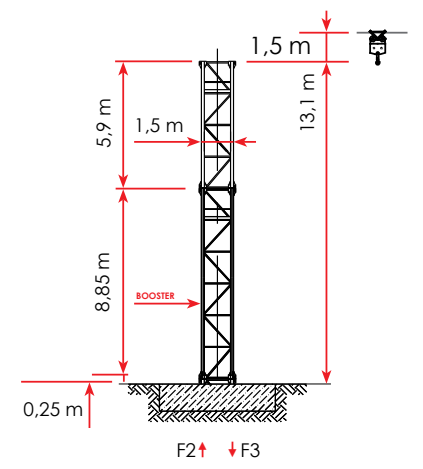

1,7 m L = 4,5 m **A**    1,7 m L = 4,5 m **B**    1,7 m L = 4,5 m **E**    1,7 m **D**

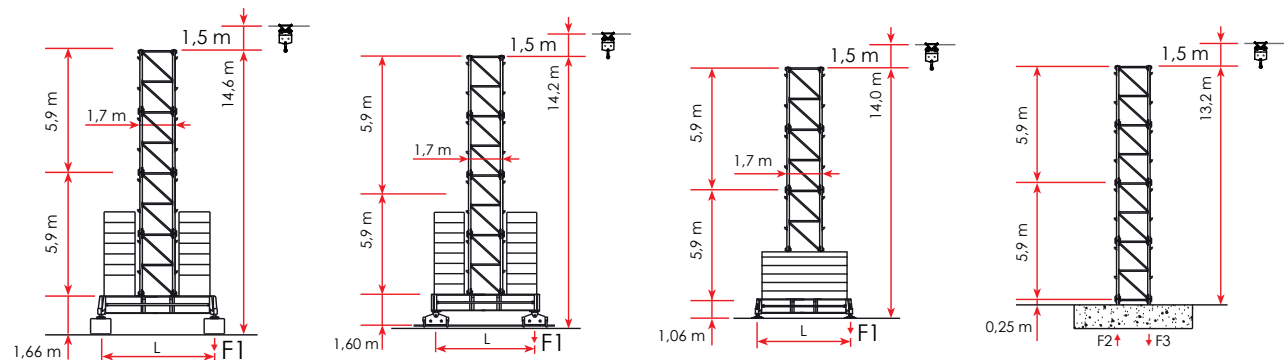

**A** 1,7 m - L = 4,5 m



$\Delta H$ (m)	H (m)	Z** (t)	F1 (kN)	$\Delta H$ (m)	H (m)	Z** (t)	F1 (kN)	$\Delta H$ (m)	H (m)	Z** (t)	F1 (kN)			
7	-	-	-	7	-	-	-	7	2,95	49,9	92,4	993		
6	2,95	47,0	86,5	896	6	-	-	-	6	2,95	46,9	80,6	874	
5	5,9	44,1	74,7	768	5	2,95	38,1	86,5	786	5	5,9	44,0	80,6	760
4	5,9	38,2	62,9	566	4	2,95	35,2	74,7	656	4	5,9	38,1	80,6	594
3	5,9	32,3	45,2	421	3	5,9	32,2	62,9	543	3	5,9	32,2	68,8	479
2	5,9	26,4	45,2	397	2	5,9	26,3	51,1	411	2	5,9	26,3	68,8	454
+1	5,9	20,5	45,2	373	+1	5,9	20,5	45,2	376	+1	5,9	20,5	68,8	440

**Z\*\***  **Comply with the specified ballast Z(t) /** Attenersi alla zavorra indicata Z(t) / S'en tenir au lest indiqué Z(t) / Unbedingt die angegebenen Ballastwerte einhalten Z(t) / Соблюдать указанный балласт Z(t)

**H\*** **Climbing cage connection frame including /** Telaio di raccordo a spinta incluso / Elément de telescopage compris / Verbindungsrahmen und drücken inbegriffen / Включая соединительную раму подъемной клетки

STANDARD 1,7 HC 8t

**B** 1,7 m HC - L = 4,5 m



$\Delta H$ (m)	H (m)	Z** (t)	F1 (kN)	$\Delta H$ (m)	H (m)	Z** (t)	F1 (kN)	$\Delta H$ (m)	H (m)	Z** (t)	F1 (kN)			
7	-	-	-	7	-	-	-	7	2,95	49,6	100,3	995		
6	2,95	46,6	82,6	884	6	-	-	-	6	2,95	46,6	88,5	876	
5	5,9	43,7	70,8	757	5	2,95	37,8	82,6	775	5	5,9	43,7	76,7	757
4	5,9	37,8	53,1	556	4	5,9	34,9	70,8	646	4	5,9	37,8	64,9	564
3	5,9	31,9	41,3	416	3	5,9	31,9	53,1	531	3	5,9	31,9	64,9	474
2	5,9	26,0	41,3	391	2	5,9	26,0	35,4	379	2	5,9	26,0	64,9	449
+1	5,9	20,1	41,3	368	+1	5,9	20,1	35,4	357	+1	5,9	20,1	64,9	440

**E** 1,7 m HC - L = 4,5 m

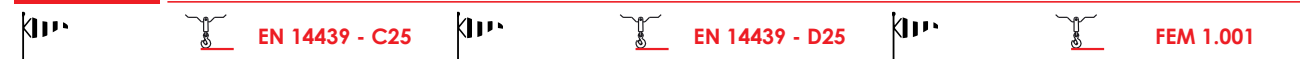

$\Delta H$ (m)	H (m)	Z** (t)	F1 (kN)	$\Delta H$ (m)	H (m)	Z** (t)	F1 (kN)	$\Delta H$ (m)	H (m)	Z** (t)	F1 (kN)			
7	-	-	-	7	-	-	-	7	2,95	49,4	100,3	978		
6	2,95	46,4	82,6	876	6	-	-	-	6	2,95	46,4	88,5	860	
5	5,9	43,5	70,8	749	5	2,95	37,5	82,6	766	5	5,9	43,5	76,7	742
4	5,9	37,6	53,1	549	4	2,95	34,5	70,8	637	4	5,9	37,6	53,1	509
3	5,9	31,7	41,3	410	3	5,9	31,6	53,1	524	3	5,9	31,7	41,3	380
2	5,9	25,8	41,3	386	2	5,9	25,7	41,3	373	2	5,9	25,8	41,3	360
+1	5,9	19,9	41,3	362	+1	5,9	19,9	41,3	351	+1	5,9	19,9	41,3	341

**Z\*\***  **Comply with the specified ballast Z(t) /** Attenersi alla zavorra indicata Z(t) / S'en tenir au lest indiqué Z(t) / Unbedingt die angegebenen Ballastwerte einhalten Z(t) / Соблюдать указанный балласт Z(t)

**D** 1,7 m **STANDARD AND SPECIAL 1,7 HC - 8t**

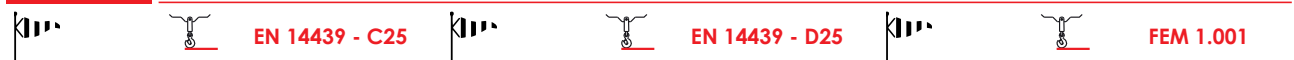

EN 14439 - C25					EN 14439 - D25					FEM 1.001				
$\Delta H$ (m)	H* (m)	F2 (kN)	F3 (kN)		$\Delta H$ (m)	H* (m)	F2 (kN)	F3 (kN)		$\Delta H$ (m)	H* (m)	F2 (kN)	F3 (kN)	
7	-	-	-	-	7	-	-	-	-	7	2,95	48,5	1845	1644
6	2,95	45,6	1289	1074	6	-	-	-	-	6	2,95	45,5	1181	1048
5	5,9	42,7	1114	903	5	3,0	36,8	1118	914	5	5,9	42,7	1087	881
4	5,9	36,8	826	623	4	3,0	33,8	942	743	4	5,9	36,8	766	608
3	5,9	30,9	661	480	3	5,9	30,9	782	587	3	5,9	30,9	602	450
2	5,9	25,0	601	428	2	5,9	25,0	601	428	2	5,9	25,0	550	402
+1	5,9	19,1	550	385	+1	5,9	19,1	550	385	+1	5,9	19,1	502	360

**H\*** Climbing cage connection frame including / Telaio di raccordo a spinta incluso / Elément de telescopage compris / Verbindungsrahmen und drücken inbegriffen / Включая соединительную раму подъемной клетки

 For different heights contact the technical department / Per altezze diverse contattare l'ufficio tecnico / Pour des hauteurs différentes contactez le département technique / Für unterschiedliche Höhen Kontakt zum Technischen / Недопустимо увеличение высоты крана без согласования с технической службой производителя

 Position of next anchor to increase height under hook / Posizione prossimo ancoraggio per aumento altezza sotto gancio / Position du prochain ancrage pour augmenter la hauteur sous crochet / Lage nächste Verankerung zur Erhöhung unter dem Haken / положение для следующего якоря большей высоты под крюком

 Anchor position / Posizione d'ancoraggio / Position de ancrage / Verankerungsposition / позицию анкеровки

**FEM 1.001**

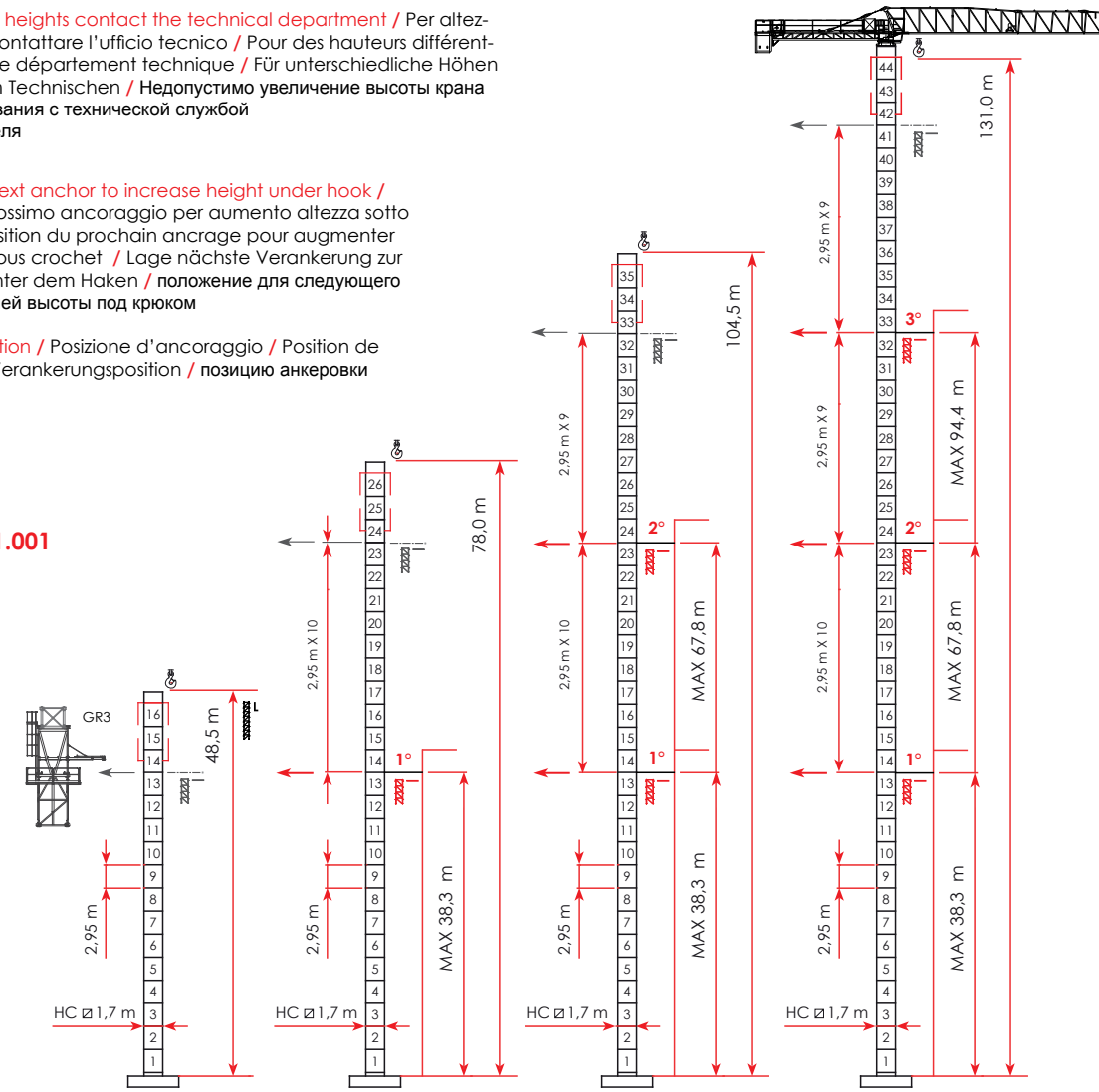

Climbing crane / Sopralzo idraulico / Télescopage sur dalles / Kletterkrane im Gebäude / Кран поднимающийся на плитах перекрытия



For different heights contact the technical department / Per altezze diverse contattare l'ufficio tecnico / Pour des hauteurs différentes contact le département technique / Für unterschiedliche Höhen Kontakt zum Technischen / Недопустимо увеличение высоты крана без согласования с технической службой производителя



Position of next anchor to increase height under hook / Posizione ancoraggio per aumento altezza sotto gancio / Position du prochain ancrage pour augmenter la hauteur sous crochet / Lage nächste Verankerung zur Erhöhung unter dem Haken / положение для следующего якоря большей высоты под крюком





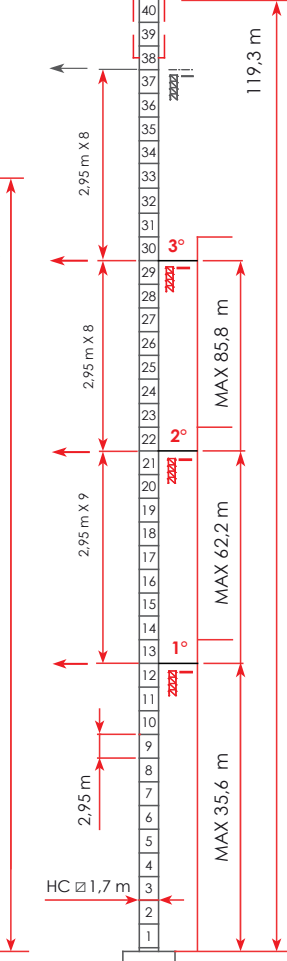
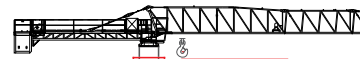

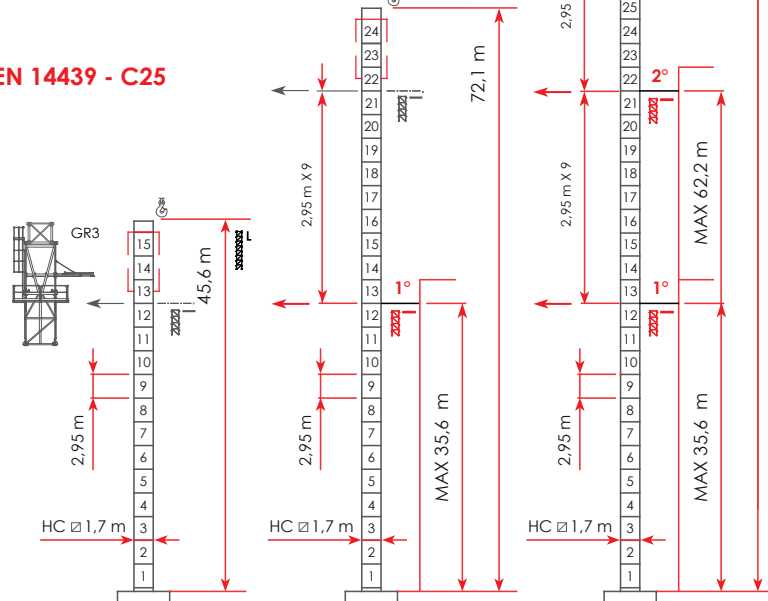

Anchor position / Posizione d'ancoraggio / Position de ancrage / Verankerungsposition / позицию анкеровки

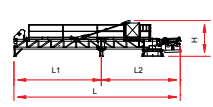

EN 14439 - C25



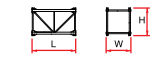
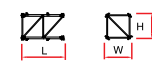

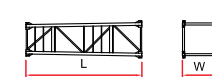
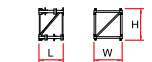
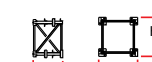
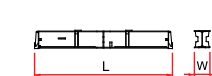

Description	Item n.	Pz n°	Drawing	Dimension ( m )			Weight ( kg )	
				l	w	h	Unit	Total
<b>Jib element</b>								
Elemento freccia	1	1		11,960	1,200	2,380	2186	-
Élément de flèche	2			6,110	1,200	2,070	773	-
Auslegerelement jib section	3			6,100	1,200	2,070	741	-
Секция стрелы	4			6,070	1,200	1,670	574	-
	5			6,030	1,200	1,660	501	-
	6			6,015	1,200	1,660	453	-
	7			6,015	1,200	1,620	437	-
	8			5,985	1,200	1,085	387	-
	9A			3,070	1,200	1,070	184	-
	9B			3,070	1,200	1,070	184	-
	10			2,940	1,200	1,070	188	-

Description	Item n.	Pz n°	Drawing	Dimension ( m )			Weight ( kg )		
				l	w	h	Unit	Total	
<b>Counterjib - tournable, hoisting winch, trolley jib, electrical box, terminal element</b> / Controfreccia - girevole, argano sollevamento, quadro elettrico, carrello freccia, portablocchi / Contreflèche tournante, treuil de levage, chariot de flèche, armoire électrique, élément terminal / Gegenausleger, Hubwinde, Laufkatze, Schaltschrank, Element für Gegengewichts Blöcke anführen / Консоль с поворотным кругом, лебедка, тележка, эл. ящик, противовесная консоль	2	1		L1	6,25	2,230	2,550	3300	-
				L2	5,65	2,230	2,550	3915	-
				L	11,90	2,230	2,550	7215	-
				L1	7,85	2,230	2,550	3,850	-
				L2	5,65	2,230	2,550	4510	-
				L	13,50	3,380	2,550	8360	-
<b>Access balcony, cabin</b> / Ballatoio cabina, cabina / Porte cabine / Kabine Podest, Kabine / Платформа кабины, кабина	3	1		3,050	1,990	2,295	963	-	
<b>Counterweight block</b> / Blocchi di contrappeso / Contre - poids / Gegengewichts Blöcke / Блоки противовеса	4	4		A99+3	1,430	0,265	2,800	2131	-
				B99+3	1,430	0,210	2,800	1684	8420
<b>Terminal element</b> / Elemento portablocchi / Elément terminal / Element für Gegengewichts Blöcke anführen / Блокодержатель	5	1		2,580	2,278	1,485	540	-	
<b>Tower element</b> / Elementi di torre / Elément de mature / Turmstück / Башенные секции	6	-		CITY 1,5	2,95	1,500	1,700	1400	-
<b>Tower element</b> / Elementi di torre / Elément de mature / Turmstück / Башенные секции	7	-		HC3 - 1,7	2,95	1,850	1,850	950	-
<b>Tower element</b> / Elementi di torre / Elément de mature / Turmstück / Башенные секции	8	-		CITY 1,5	4,425	1,700	1,500	1642	-

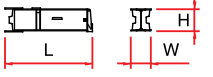
Description	Item n.	Pz n°	Drawing	Dimension ( m )			Weight ( kg )		
				l	w	h	Unit	Total	
<b>Tower element</b> / Elementi di torre / Elément de mature / Turmstück / Башенные секции	9	1		TP 1715	5,90	1,900	1,700	2245	-
				CITY 1,5	5,90	1,500	1,700	2070	-
				HC3 - 1,7	5,90	1,850	1,850	1695	-
				CITY 1,5	11,80	1,500	1,700	3870	-
				HC3 - 1,7	11,80	1,850	1,850	3235	-
				CITY 1,5	1,465	1,780	1,780	795	-
				HC3 - 1,7	1,325	1,960	1,960	624	-
<b>Expendable foundation element</b> / Tronchetto di fondazione / Elément a sceller / Fundamentanker / Анкер	14	1		CITY 1,5	1,465	1,780	1,780	795	-
<b>Expendable foundation element</b> / Tronchetto di fondazione / Elément a sceller / Fundamentanker / Анкер	15	1		HC3 - 1,7	1,325	1,960	1,960	624	-
<b>Base main beam</b> / Trave principale crosiera di base / Poutre de chassis de base / Haupt-träger für Kreuzbase / Главная балка крестовины основания	16	1		CITY 1,5	4,530	0,710	0,760	2450	-
				HC3 - 1,7	4,530	0,710	0,760	2450	-

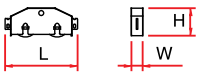
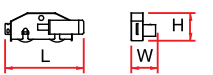

Description	Item	Pz	Drawing	Dimension ( m )			Weight ( kg )		
				n.	n°	l	w	h	Unit
<b>Half base beam /</b> Semitrave di base / Semipoutre de chassis de base / Halb-träger für Kreuzbase / Полубалка основания	17	2		<b>CITY 1,5 4,5 x 4,5 m</b>			1090	2180	
				3,200	0,590	0,770			
				<b>HC3 - 1,7</b>			1090	2180	
				3,200	0,590	0,770			
<b>Concrete pad /</b> Blocco di appoggio / Sabot en béton / Beton Fuß / Опорный блок	18	4		<b>CITY 1,5 B2</b>			3925	15700	
				3,600	0,800	0,600			
				<b>HC3 - 1,7 B2</b>			3925	15700	
				3,600	0,800	0,600			
<b>Driving bogie /</b> Bilancino di traslazione folle/ Boggie fou / Schaukel Bewegung - Neutralstellung / Не приводной балансир	19	2		<b>CITY 1,5</b>			415	830	
				1,080	0,230	0,515			
				<b>HC3 - 1,7</b>			415	830	
				1,080	0,230	0,515			
<b>Driven bogie /</b> Bilancino di traslazione motorizzato / Boggie motorisée / Schau- kel Bewegung - Betriebene / Приводной балансир	20	2		<b>CITY 1,5</b>			535	1070	
				1,550	0,500	0,515			
				<b>HC3 - 1,7</b>			535	1070	
				1,550	0,500	0,515			
<b>Base ballast block /</b> Blocco di zavorra / Lest de base / Grundballast / блок балласта	21	-		<b>GB3</b>			2950	-	
				3,600	1,200	0,300	2950	-	

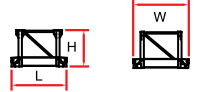
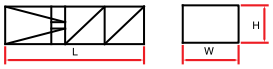
Description	Item	Pz	Drawing	Dimension ( m )			Weight ( kg )		
				n.	n°	l	w	h	Unit
<b>Climbing cage connection frame /</b> Telaio di raccordo a spinta / Elément de telescopage / Verbindungsrahmen und drücken / Переходной элемент	22			<b>HC3 - 1,7</b>			690	-	
				1,500	1,970	1,970			
<b>Climbing Cage /</b> Gabbia di montaggio / Semipoutre de chassis de base / Montagekäfig	23			<b>GR3 - 1,7</b>			4200	-	
				7,160	2,530	2,390			



3 x 13,60 m

MRT111 HC \_Jib 60 m • HUH 0,0 m

Top part / Parte rotante / Partie tournante / Drehender Kranteil / Поворотная часть



2 x 40 High cube

 Included counter weight and cabin / Cabina e contrappesi inclusi / Cabine et  
 contrepoids inclus / Kabine und Gegengewichts Blöcke – inbegriffen / Противовес  
 включен - кабина

2 x 40 Open Top



The Raimondi MRT159 topless tower crane, equipped with a 65 meter jib length and a maximum tip load of 1650 kg, has more jib configurations available and a selection of three different winches with respective powers of 30 kW and 45 kW

# MRT159

## 8t

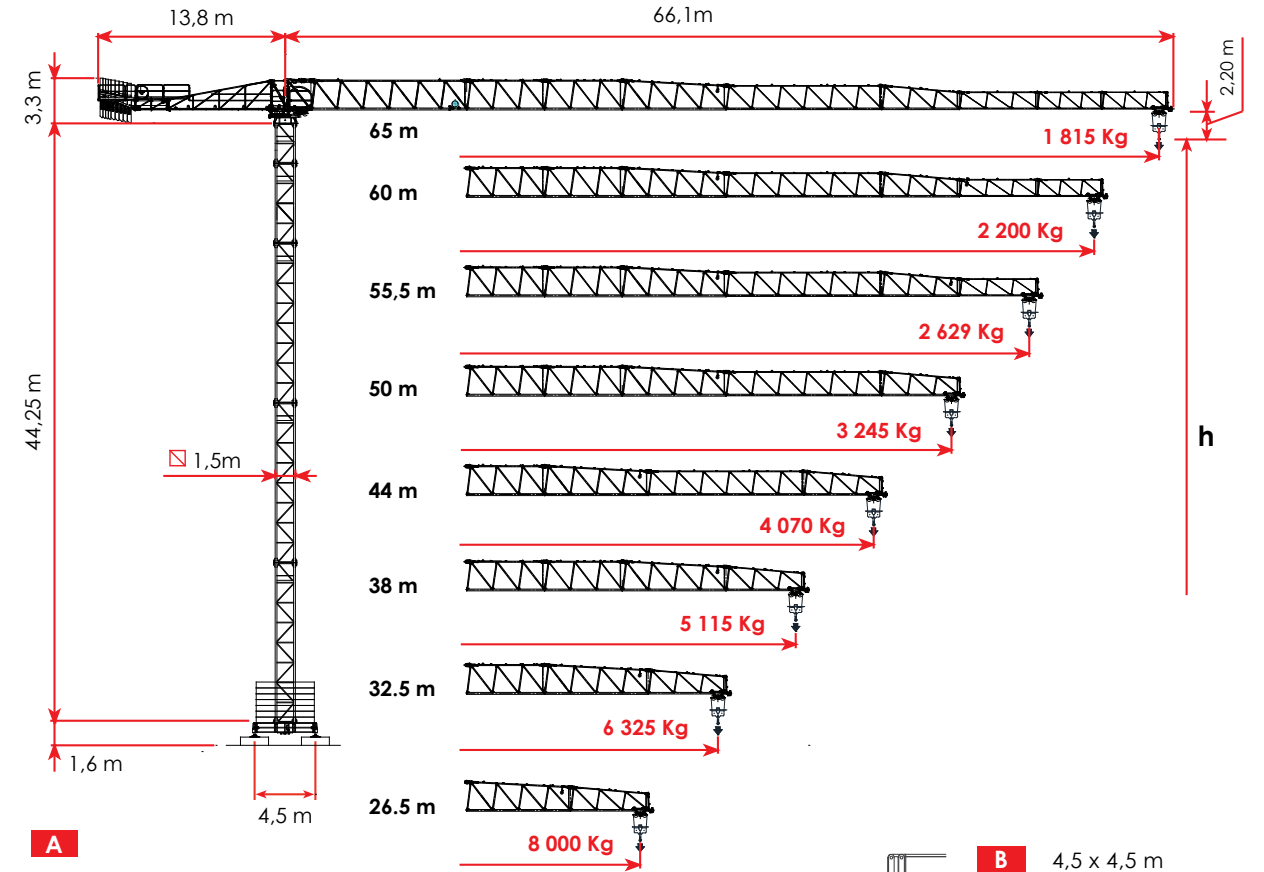

**A**  
 4,5 x 4,5 m  
 h 44,8 m C25  
 h 44,8 m D25  
 h 47,8 m FEM 1.001

**B**  
 4,5 x 4,5 m  
 h 44,4 m C25  
 h 44,4 m D25  
 h 47,4 m FEM 1.001

    
 2000/14/CE  
 A4 EN 14439 C25 D25 - FEM 1.001















**D**  
 h 43,4 m C25  
 h 43,4 m D25  
 h 46,4 m FEM 1.001

**E**  
 4,5 x 4,5 m  
 h 44,2 m C25  
 h 44,2 m D25  
 h 47,2 m FEM 1.001



# RAIMONDI<sup>®</sup> MRT159

SINCE 1863

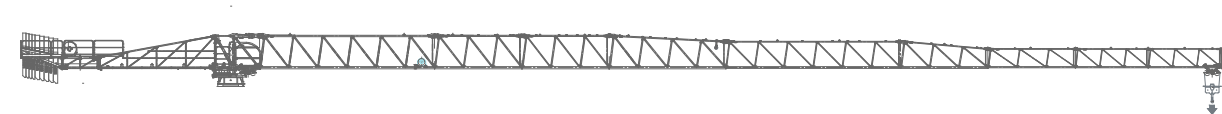

IT	EN	F	DE	RU
 Altezza sotto gancio	Height under hook	Hauteur sous crochet	Höhe unter dem Haken	Высота под крюком
 Contrappesi	Counter weight jib ballast	Lest de contre-flèche	Gegenauslegerballast	Противовесы
 Freccia	Jib	Flèche	Kranarm	стрела крана
 Carico massimo	Max load	Charge maximale	Maximale Belastung	максимальная нагрузка
 Curva di carico Ultralift	Load diagrams with ultralift control	Courbes de charges Ultralift	Lastkurven Ultralift	Кривой Груз Ultralift
 Altezza libera	Free Standing	Hauteur libre	Freistehend	Свободностоящая высота
 Azionamenti	Mechanisms	Mécanismes	Antriebe	Приводы
 Velocità	Speed	Vitesse	Geschwindigkeit	скорость
<b>4* - 5*</b>  Marce con velocità proporzionale al carico	5 step with speed proportional to the load	5 rapports avec une vitesse proportionnelle à la charge	5 Gang Geschwindigkeit proportional zum Last	Автоматический выбор скорости механизма подъема в зависимости от величины груза
 Tiro a 2 funi	Two - rope pull	Tir à deux câbles	Zug an zwei Seilen	Двукратная запасовка тросов
 Tiro a 4 funi	Four - rope pull	Tir à quatre câbles	Zug an vier Seilen	Четырехкратная запасовка тросов
 Totale metri fune tamburo	Total meters rope drum	Total des mètres de corde du tambour	Total Meter Seil Trommel	Запас троса на барабане в метрах
 Diametro fune	Rope diameter	Diamètre du câble	Seildurchmesser	Диаметр троса
 Rotazione	Slewing	Orientation	Schwenken	Поворот
 Carrello	Trolley	Chariot	Katzfahren	Тележка



kg	m	8,0 t	26,5 m	32,5 m	38,0 m	44,0 m	50,0 m	55,5 m	60,0 m	65,0 m
19.236	<b>65</b>	17,9	5197	4133	3457	2916	2506	2209	2006	<b>1815</b>
17.879	<b>60</b>	19,3	5641	4493	3765	3181	2738	2418	<b>2200</b>	
17.879	<b>55,5</b>	20,6	6088	4856	4074	3447	2973	<b>2629</b>		
16.184	<b>50</b>	22,2	6607	5278	4434	3757	<b>3245</b>			
14.161	<b>44</b>	23,8	7131	5703	4797	<b>4070</b>				
13.495	<b>38</b>	25,2	7591	6076	<b>5115</b>					
12.138	<b>32,5</b>	26,2	7897	<b>6325</b>						
10.115	<b>26,5</b>	26,5	<b>8000</b>							



 400 V ± 5% 50 Hz

 2000 / 14 / CE

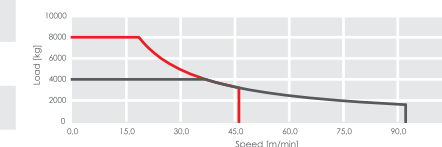
	STEP	m/min	kg	m/min	kg
 450 m	1	7	4000	3,5	8000
 70 kVA	2	25	4000	12,5	8000
 Ø 12 mm	3	43	4000	21,5	8000
	4	68	2200	34,0	4400
	5	93	1300	46,5	2600
	<b>5*</b>	100	600	50,0	1200



kVA Power required / Potenza richiesta / Puissance requise / Erforderliche Leistung / Потребляемая мощность

 0,37/0,7/1,0 min<sup>-1</sup> • 2 x 4 kW /  15,0/42,0/67,0/ 75,0 (\*) m/min • 5,5 kW /  19 m/min • 2 x 2,9 kW

 400 V ± 5% 50 Hz



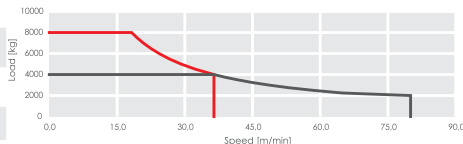

 2005 / 88 / CE

**8,0 t 60 hp 45 kW**

	STEP	Icon II		Icon IV	
		m/min	kg	m/min	kg
840 m	1	↓	↓	↓	↓
95 kVA	2	45	4000	22,5	8000
Ø 12 mm	3	↓	↓	↓	↓
	4	82	2000	41,0	4000
	5	↓	↓	↓	↓
	5*	136	1000	68	2000

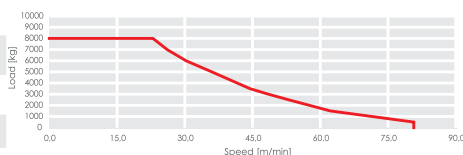
**8,0 t 40 hp 30 kW**

	STEP	Icon II		Icon IV	
		m/min	kg	m/min	kg
440 m	1	0	↓	-	-
70 kVA	2	23	8000	-	-
Ø 16 mm	3	↓	↓	-	-
	4	40	4000	-	-
	5	↓	↓	-	-
	5*	80	500	-	-

 0,37/0,7/1,0 min<sup>-1</sup> • 2 x 4 kW /  15,0/42,0/67,0/ 75,0 (°) m/min • 5,5 kW /  19 m/min • 2 x 2,9 kW

**MRT159 - 8,0t - T2**

JIB	26,5	32,5	38	44	50	55,5	60	65
1,6 ▶	<b>26,5</b>	<b>26,2</b>	<b>25,2</b>	<b>23,8</b>	<b>22,2</b>	<b>20,6</b>	<b>19,3</b>	<b>17,9</b>
17	8000	8000	8000	8000	8000	8000	8000	8000
18	8000	8000	8000	8000	8000	8000	8000	7961
20	8000	8000	8000	8000	8000	8000	7686	7093
23	8000	8000	8000	8000	7712	7112	6594	6081
<b>26,5</b>	<b>8000</b>	7897	7591	7131	6607	6088	5641	5197
30		6902	6632	6227	5766	5308	4914	4523
<b>32,5</b>		<b>6325</b>	6076	5703	5278	4856	4493	4133
36			5430	5094	4710	4331	4003	3679
<b>38</b>			<b>5115</b>	4797	4434	4074	3765	3457
40				4530	4185	3844	3550	3258
<b>44</b>				<b>4070</b>	3757	3447	3181	2916
46					3571	3275	3020	2767
<b>50</b>					<b>3245</b>	2973	2738	2506
52						2839	2614	2390
<b>55,5</b>						<b>2629</b>	2418	2209
<b>60</b>							<b>2200</b>	2006
<b>65</b>								<b>1815</b>



**MRT159 - 8,0t - T4**

JIB	26,5	32,5	38	44	50	55,5	60	65
1,6 ▶	<b>26,5</b>	<b>26,2</b>	<b>25,2</b>	<b>23,8</b>	<b>22,2</b>	<b>20,6</b>	<b>19,3</b>	<b>17,9</b>
17	8000	8000	8000	8000	8000	8000	8000	8000
18	8000	8000	8000	8000	8000	8000	8000	7961
20	8000	8000	8000	8000	8000	8000	7686	7093
23	8000	8000	8000	8000	7712	7112	6594	6081
<b>26,5</b>	<b>8000</b>	7897	7591	7131	6607	6088	5641	5197
30		6902	6632	6227	5766	5308	4914	4523
<b>32,5</b>		<b>6325</b>	6076	5703	5278	4856	4493	4133
36			5430	5094	4710	4331	4003	3679
<b>38</b>			<b>5115</b>	4797	4434	4074	3765	3457
40				4530	4185	3844	3550	3258
<b>44</b>				<b>4070</b>	3757	3447	3181	2916
46					3571	3275	3020	2767
<b>50</b>					<b>3245</b>	2973	2738	2506
52						2839	2614	2390
<b>55,5</b>		+ 80 Kg				<b>2629</b>	2418	2209
<b>60</b>							<b>2200</b>	2006
<b>65</b>								<b>1815</b>

**ULTRALIFT** If the crane is not equipped with Ultralift control, all intermediate loads are decreased by 10% / Senza il sistema Ultralift tutte le portate intermedie diminuiscono il carico del 10% / Les charges intermediaires sont diminuees de 10% si la grue n'est pas equipé d'un controle Ultralift. / Mit dem ULTRALIFT-System erhöhen alle Zwischenbelastbarkeiten die Last um 10% / Без ULTRALI FT промежуточный вес уменьшается на 10%.

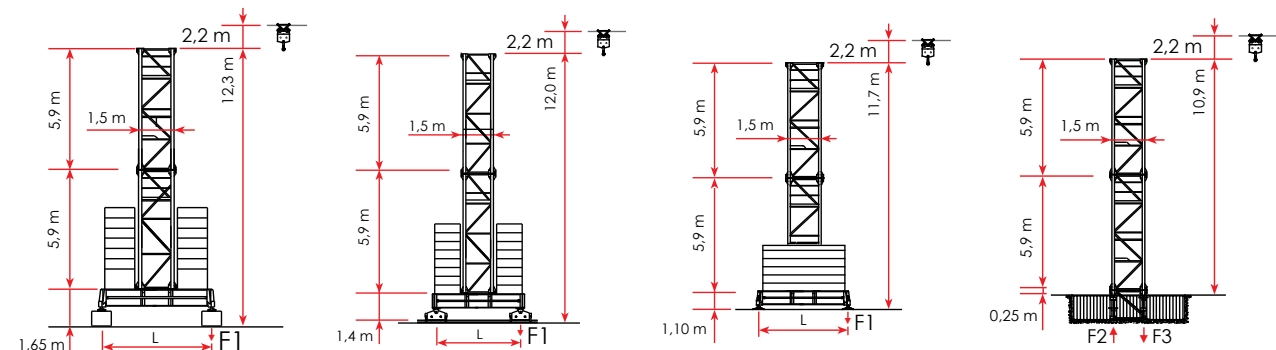

A 1,5 m L = 4,5 (m)   
 B 1,5 m L = 4,5 (m)   
 E 1,5 m L = 4,5 (m)   
 D 1,5 m



<b>A</b>	Base on concrete pads	Base su zatteroni	Grue sur blocs d'appui	Kran auf Stützblöcken	Кран на опорных блоках
<b>B</b>	Travelling base	Base traslante	Grue à traslation	Fahrbarer Kran	Кран передвижной
<b>E</b>	Base on steel pads	Base con piedi regolabili	Grue sur pieds réglables	Kran auf verstellbaren Füßen	Кран на регулируемых лапах
<b>D</b>	Crane on embedded	Gru su tronchetto	Grue sur plinthe	Kran auf Fundamentplatte	Кран на фундаменте

**A** 1,5 m - L = 4,5 m

EN 14439 - C25					EN 14439 - D25					FEM 1.001				
$\Delta H$ (m)	H (m)	Z** (t)	F1 (kN)		$\Delta H$ (m)	H (m)	Z** (t)	F1 (kN)		$\Delta H$ (m)	H (m)	Z** (t)	F1 (kN)	
7	-	-	-	-	7	-	-	-	-	8	-	-	-	-
6	2,95	44,8	98,3	663	6	2,95	44,8	98,3	836	7	2,95	47,8	110,1	735
5	5,9	41,8	92,4	627	5	5,9	41,8	92,4	684	6	2,95	44,8	98,3	666
4	5,9	35,9	86,5	578	4	5,9	35,9	86,5	538	5	5,9	41,8	92,4	630
3	5,9	30,0	80,6	533	3	5,9	30,0	80,6	533	4	5,9	35,9	86,5	581
2	5,9	24,1	74,7	493	2	5,9	24,1	74,7	493	3	5,9	30,0	80,6	535
+1	5,9	18,2	74,7	480	+1	5,9	18,2	74,7	478	+2	5,9	24,1	68,8	484

STANDARD 1,5 CITY 8t

**B** 1,5 m - L = 4,5 m

EN 14439 - C25					EN 14439 - D25					FEM 1.001				
$\Delta H$ (m)	H (m)	Z** (t)	F1 (kN)		$\Delta H$ (m)	H (m)	Z** (t)	F1 (kN)		$\Delta H$ (m)	H (m)	Z** (t)	F1 (kN)	
7	-	-	-	-	7	-	-	-	-	8	-	-	-	-
6	2,95	44,4	94,4	661	6	2,95	44,4	100,3	826	7	2,95	47,4	106,2	711
5	5,9	41,5	88,5	627	5	5,9	41,5	94,4	693	6	2,95	44,4	94,4	654
4	5,9	35,6	82,6	577	4	5,9	35,6	88,5	592	5	5,9	41,5	88,5	618
3	5,9	29,7	76,7	532	3	5,9	29,7	82,6	547	4	5,9	35,6	82,6	569
2	5,9	23,8	70,8	494	2	5,9	23,8	76,7	507	3	5,9	29,7	76,7	524
+1	5,9	17,9	70,8	487	+1	5,9	17,9	76,7	500	+2	5,9	23,8	64,9	474

**E** 1,5 m - L = 4,5 m

EN 14439 - C25					EN 14439 - D25					FEM 1.001				
$\Delta H$ (m)	H (m)	Z** (t)	F1 (kN)		$\Delta H$ (m)	H (m)	Z** (t)	F1 (kN)		$\Delta H$ (m)	H (m)	Z** (t)	F1 (kN)	
7	-	-	-	-	7	-	-	-	-	8	-	-	-	-
6	2,95	44,2	94,4	654	6	2,95	44,2	100,3	815	7	2,95	47,2	106,2	717
5	5,9	41,2	88,5	618	5	5,9	41,2	94,4	674	6	2,95	44,2	94,4	655
4	5,9	35,3	82,6	568	4	5,9	35,3	88,5	583	5	5,9	41,2	88,5	619
3	5,9	29,4	76,7	523	3	5,9	29,4	82,6	538	4	5,9	35,3	82,6	569
2	5,9	23,5	70,8	487	2	5,9	23,5	76,7	500	3	5,9	29,4	76,7	524
+1	5,9	17,6	70,8	481	+1	5,9	17,6	76,7	494	+2	5,9	23,5	64,9	474

**Z\*\***  Comply with the specified ballast Z(t) / Attenersi alla zavorra indicata Z(t) / S'en tenir au lest indiqué Z(t) / Unbedingt die angegebenen Ballastwerte einhalten Z(t) / Соблюдать указанный балласт Z(t)

**D** 1,5 m STANDARD 1,5 CITY 8t

EN 14439 - C25					EN 14439 - D25					FEM 1.001				
$\Delta H$ (m)	H (m)	F2 (kN)	F3 (kN)		$\Delta H$ (m)	H (m)	F2 (kN)	F3 (kN)		$\Delta H$ (m)	H* (m)	F2 (kN)	F3 (kN)	
7	-	-	-	-	7	-	-	-	-	-	-	-	-	-
6	2,95	43,4	1039	784	6	2,95	43,4	1395	1133	9	-	-	-	-
5	5,9	40,4	979	730	5	5,9	40,4	1148	893	8	2,95	46,4	790	555
4	5,9	34,5	878	639	4	5,9	34,5	878	639	7	2,95	43,4	709	478
3	5,9	28,6	791	589	3	5,9	28,6	791	589	6	2,95	40,4	679	451
2	5,9	22,7	772	587	2	5,9	22,7	772	587	5	2,95	37,4	625	412
+1	5,9	16,8	762	588	+1	5,9	16,8	762	588	+4	5,9	34,5	585	404

1,7 m L = 4,5 m **A** 1,7 m L = 4,5 m **B** 1,7 m L = 4,5 m **E** 1,7 m **D**

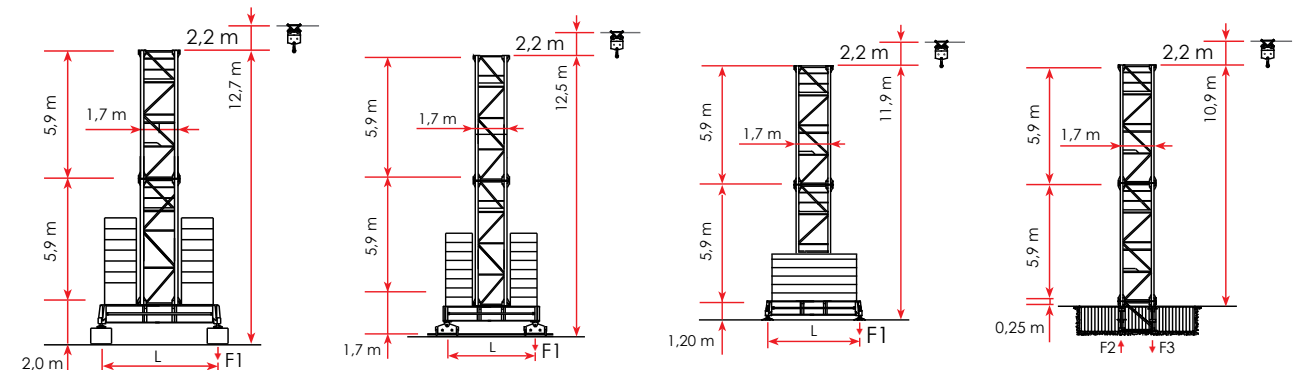



- A** Base on concrete pads / Base su zatteroni / Grue sur blocs d'appui / Kran auf Stützblöcken / Кран на опорных блоках
- B** Travelling base / Base traslante / Grue à traslation / Fahrbarer Kran / Кран передвижной
- E** Base on steel pads / Base con piedi regolabili / Grue sur pieds réglables / Kran auf verstellbaren Füßen / Кран на регулируемых лапах
- D** Crane on embedded / Gru su tronchetto / Grue sur plinthe / Kran auf Fundamentplatte / Кран на фундаменте



**A** 1,7 m - City L = 4,5 m

EN 14439 - C25					EN 14439 - D25					FEM 1.001				
$\Delta H$ (m)	H (m)	Z** (t)	F1 (kN)		$\Delta H$ (m)	H (m)	Z** (t)	F1 (kN)		$\Delta H$ (m)	H (m)	Z** (t)	F1 (kN)	
8	2,95	54,0	124,1	1084	7	2,95	48,1	103,7	1040	9	-	-	-	-
7	2,95	51,0	113,9	932	6	2,95	45,1	93,5	859	8	2,95	54,0	110,6	911
6	5,9	48,1	103,7	792	5	5,9	42,2	83,3	708	7	2,95	51,0	98,8	772
5	5,9	42,2	93,5	665	4	5,9	36,3	83,3	570	6	5,9	48,2	87,0	672
4	5,9	36,3	83,3	604	3	5,9	30,4	83,3	543	5	5,9	42,2	81,1	606
3	5,9	30,4	83,3	573	2	5,9	24,5	83,3	514	4	5,9	36,3	69,3	541
+2	5,9	24,5	83,3	546	+1	5,9	18,6	83,3	498	+3	5,9	30,4	69,3	510

**B**  **1,7 m - City** L = 4,5 m **STANDARD 1,7 CITY 8t**



 <b>EN 14439 - C25</b>					 <b>EN 14439 - D25</b>					 <b>FEM 1.001</b>				
$\Delta H$ (m)	H (m)	Z** (t)	F1 (kN)		$\Delta H$ (m)	H (m)	Z** (t)	F1 (kN)		$\Delta H$ (m)	H (m)	Z** (t)	F1 (kN)	
8	2,95	53,8	122,4	978	7	2,95	47,9	102,0	1041	9	-	-	-	-
7	2,95	50,8	112,2	822	6	2,95	44,9	91,8	859	8	2,95	53,8	112,1	911
6	5,9	47,9	102,0	725	5	5,9	42,0	81,6	707	7	2,95	50,8	100,3	772
5	5,9	42,0	91,8	630	4	5,9	36,1	81,6	573	6	5,9	47,9	88,5	682
4	5,9	36,1	81,6	570	3	5,9	30,2	81,6	543	5	5,9	42,0	82,6	617
3	5,9	30,2	81,6	541	2	5,9	24,3	81,6	518	4	5,9	36,1	70,8	551
+2	5,9	24,3	81,6	522	+1	5,9	18,4	81,6	501	+3	5,9	30,2	70,8	521

**E**  **1,7 m - City** L = 4,5 m

 <b>EN 14439 - C25</b>					 <b>EN 14439 - D25</b>					 <b>FEM 1.001</b>				
$\Delta H$ (m)	H (m)	Z** (t)	F1 (kN)		$\Delta H$ (m)	H (m)	Z** (t)	F1 (kN)		$\Delta H$ (m)	H (m)	Z** (t)	F1 (kN)	
8	2,95	53,2	122,4	950	7	2,95	47,3	102,0	1009	9	-	-	-	-
7	2,95	50,3	112,2	803	6	2,95	44,4	91,8	830	8	2,95 m	53,2	112,1	892
6	5,9	47,3	102,0	707	5	5,9	41,4	91,8	681	7	2,95 m	50,2	100,3	754
5	5,9	41,4	91,8	621	4	5,9	35,5	81,6	564	6	5,9 m	47,3	88,5	667
4	5,9	35,5	81,6	561	3	5,9	29,6	81,6	535	5	5,9 m	41,4	82,6	608
3	5,9	29,6	81,6	532	2	5,9	23,7	81,6	509	4	5,9 m	35,5	70,8	542
+2	5,9	23,7	81,6	515	+1	5,9	17,8	81,6	494	+3	5,9 m	29,6	70,8	512

**Z\*\***  **Comply with the specified ballast Z(t) / Attenersi alla zavorra indicata Z(t) / S'en tenir au lest indiqué Z(t) / Unbedingt die angegebenen Ballastwerte einhalten Z(t) / Соблюдать указанный балласт Z(t)**

**D**  **1,7 m - City** **STANDARD 1,7 CITY 8t**

 <b>EN 14439 - C25</b>					 <b>EN 14439 - D25</b>					 <b>FEM 1.001</b>				
$\Delta H$ (m)	H (m)	F2 (kN)	F3 (kN)		$\Delta H$ (m)	H (m)	F2 (kN)	F3 (kN)		$\Delta H$ (m)	H (m)	F2 (kN)	F3 (kN)	
9	-	-	-	-	8	-	-	-	-	-	-	-	-	-
8	2,95	52,2	1420	1135	7	2,95	46,3	1492	1218	10	-	-	-	-
7	2,95	49,3	1208	930	6	2,95	43,4	1255	987	9	2,95	52,2	1104	819
6	5,9	46,3	1013	741	5	5,9	40,4	1038	777	8	2,95	49,3	946	668
5	5,9	40,4	851	598	4	5,9	34,5	774	530	7	2,95	46,3	801	530
4	5,9	34,5	766	524	3	5,9	28,6	700	496	6	2,95	43,3	713	459
+3	5,9	28,6	698	502	+2	5,9	22,7	684	497	+5	5,9	40,4	643	400

HC 1,7m L = 4,5m **A** 1,7 m L = 4,5 (m) **B** 1,7 m L = 4,5 (m) **E** 1,7 m **D**

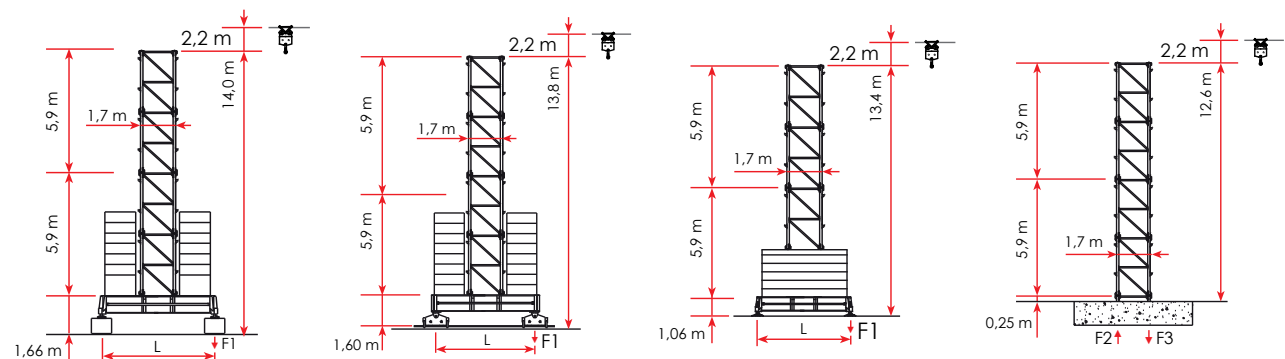

**H\*** Climbing cage connection frame including / Telaio di raccordo a spinta incluso / Elément de telescopage compris / Включая соединительную раму подъемной клетки

**A** 1,7 m - L = 4,5 m

EN 14439 - C25 EN 14439 - D25 FEM 1.001

$\Delta H$ (m)	H* (m)	Z** (t)	F1 (kN)	$\Delta H$ (m)	H* (m)	Z** (t)	F1 (kN)	$\Delta H$ (m)	H* (m)	Z** (t)	F1 (kN)			
9	-	-	-	8	-	-	-	9	-	-	-			
8	-	-	-	7	-	-	-	8	2,95	52,3	116,0	827		
7	2,95	49,4	116,0	770	6	2,95	46,5	110,1	920	7	2,95	49,4	92,4	727
6	2,95	46,5	110,1	693	5	5,9	43,5	104,2	757	6	2,95	46,5	86,5	629
5	5,9	43,5	98,3	643	4	5,9	37,6	92,4	607	5	5,9	43,5	74,7	573
4	5,9	37,6	92,4	594	3	5,9	31,7	92,4	545	4	5,9	37,6	74,7	538
+3	5,9	31,7	86,5	549	+2	5,9	25,8	92,4	521	+3	5,9	31,7	74,7	510

**Z\*\*** Comply with the specified ballast Z(t) / Attenersi alla zavorra indicata Z(t) / S'en tenir au lest indiqué Z(t) / Unbedingt die angegebenen Ballastwerte einhalten Z(t) / Соблюдать указанный балласт Z(t)

STANDARD 1,7 HC3 - 8t

**B** 1,7 m - L = 4,5 m

EN 14439 - C25 EN 14439 - D25 FEM 1.001

$\Delta H$ (m)	H* (m)	Z** (t)	F1 (kN)	$\Delta H$ (m)	H* (m)	Z** (t)	F1 (kN)	$\Delta H$ (m)	H* (m)	Z** (t)	F1 (kN)			
8	-	-	-	8	-	-	-	9	-	-	-			
7	2,95	49,2	112,1	762	7	-	-	8	2,95	52,1	112,1	827		
6	2,95	46,2	106,2	690	6	2,95	46,2	106,2	913	7	2,95	49,2	88,5	726
5	5,9	43,3	94,4	640	5	5,9	43,3	100,3	761	6	2,95	46,2	82,6	625
4	5,9	37,4	88,5	591	4	5,9	37,4	88,5	591	5	5,9	43,3	70,8	569
3	5,9	31,5	82,6	546	3	5,9	31,5	88,5	558	4	5,9	37,4	70,8	534
+2	5,9	25,6	76,7	505	+2	5,9	25,6	88,5	533	+3	5,9	31,5	70,8	505

**E** 1,7 m - L = 4,5 m

EN 14439 - C25 EN 14439 - D25 FEM 1.001

$\Delta H$ (m)	H* (m)	Z** (t)	F1 (kN)	$\Delta H$ (m)	H* (m)	Z** (t)	F1 (kN)	$\Delta H$ (m)	H* (m)	Z** (t)	F1 (kN)			
8	-	-	-	8	-	-	-	9	-	-	-			
7	2,95	48,8	112,1	749	7	-	-	8	2,95	51,7	112,1	810		
6	2,95	45,9	106,2	680	6	2,95	45,9	106,2	896	7	2,95	48,8	88,5	711
5	5,9	42,9	94,4	631	5	5,9	42,9	100,3	734	6	2,95	45,9	82,6	618
4	5,9	37,0	88,5	582	4	5,9	37,0	88,5	582	5	5,9	42,9	70,8	562
3	5,9	31,1	82,6	537	3	5,9	31,1	82,6	534	4	5,9	37,0	70,8	527
+2	5,9	25,2	76,7	499	+2	5,9	25,2	82,6	511	+3	5,9	31,1	70,8	499

**Z\*\*** Comply with the specified ballast Z(t) / Attenersi alla zavorra indicata Z(t) / S'en tenir au lest indiqué Z(t) / Unbedingt die angegebenen Ballastwerte einhalten Z(t) / Соблюдать указанный балласт Z(t)



**D**

□ 1,7 m - HC3

**STANDARD 1,7 HC3 - 8t**

EN 14439 - C25					EN 14439 - D25					FEM 1.001					
$\Delta H$ (m)	H* (m)	F2 (kN)	F3 (kN)		$\Delta H$ (m)	H* (m)	F2 (kN)	F3 (kN)		$\Delta H$ (m)	H* (m)	F2 (kN)	F3 (kN)		
8	-	-	-	-	8	-	-	-	-	-	-	-	-	-	-
7	2,95	48,0	1129	879	7	-	-	-	-	13	2,95	51,0	1138	653	
6	2,95	45,1	943	697	6	2,95	45,1	1351	1106	12	2,95	48,0	990	510	
5	5,9	42,1	870	636	5	5,9	42,1	1126	885	11	2,95	45,1	852	416	
4	5,9	36,2	782	555	4	5,9	36,2	782	555	10	2,95	42,1	755	366	
3	5,9	30,3	705	497	3	5,9	30,3	705	497	9	2,95	39,2	672	354	
+2	5,9	24,4	673	496	+2	5,9	24,4	673	496	+8	2,95	36,2	634	350	



**H\*** Climbing cage connection frame including / Telaio di raccordo a spinta incluso / Elément de telescopage compris / Включая соединительную раму подъемной клетки



For different heights contact the technical department / Per altezze diverse contattare l'ufficio tecnico / Pour des hauteurs différentes contact le département technique / Für unterschiedliche Höhen Kontakt zum Technischen / Недопустимо увеличение высоты крана без согласования с технической службой производителя



Position of next anchor to increase height under hook / Posizione prossimo ancoraggio per aumento altezza sotto gancio / Position du prochain ancrage pour augmenter la hauteur sous crochet / Lage nächste Verankerung zur Erhöhung unter dem Haken / положение для следующего якоря большей высоты под крюком



Anchor position / Posizione d'ancoraggio / Position de ancrage / Verankerungsposition / позицию анкеровки



FEM 1.001

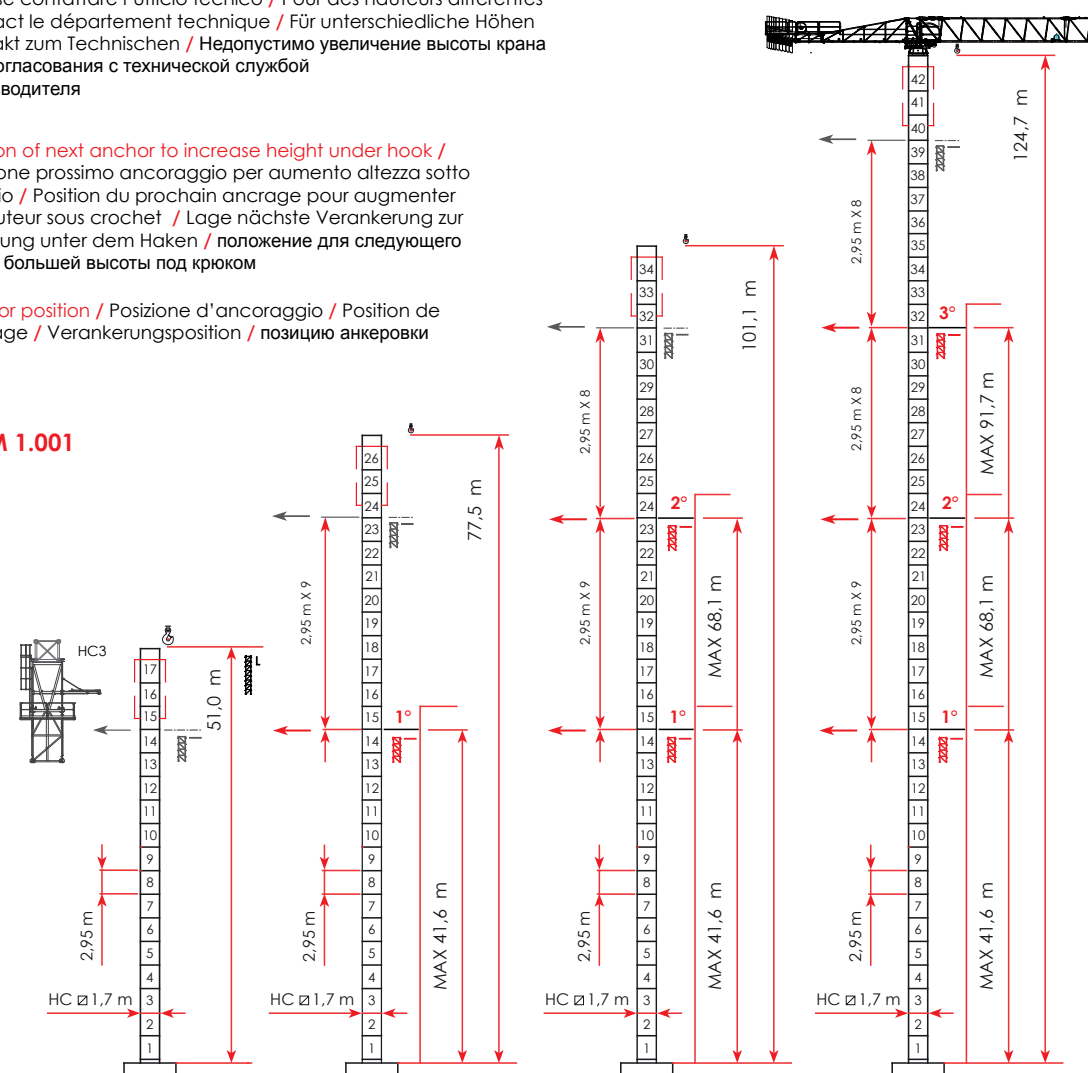

Climbing crane / Sopralzo idraulico / Télescopage sur dalles / Kletterkrane im Gebäude / Кран поднимающийся на плитах перекрытия



For different heights contact the technical department / Per altezze diverse contattare l'ufficio tecnico / Pour des hauteurs différentes contact le département technique / Für unterschiedliche Höhen Kontakt zum Technischen / Недопустимо увеличение высоты крана без согласования с технической службой производителя



Position of next anchor to increase height under hook / Posizione prossimo ancoraggio per aumento altezza sotto gancio / Position du prochain ancrage pour augmenter la hauteur sous crochet / Lage nächste Verankerung zur Erhöhung unter dem Haken / положение для следующего якоря большей высоты под крюком



Anchor position / Posizione d'ancoraggio / Position de ancrage / Verankerungsposition / позицию анкеровки



**EN 14439 - C25**

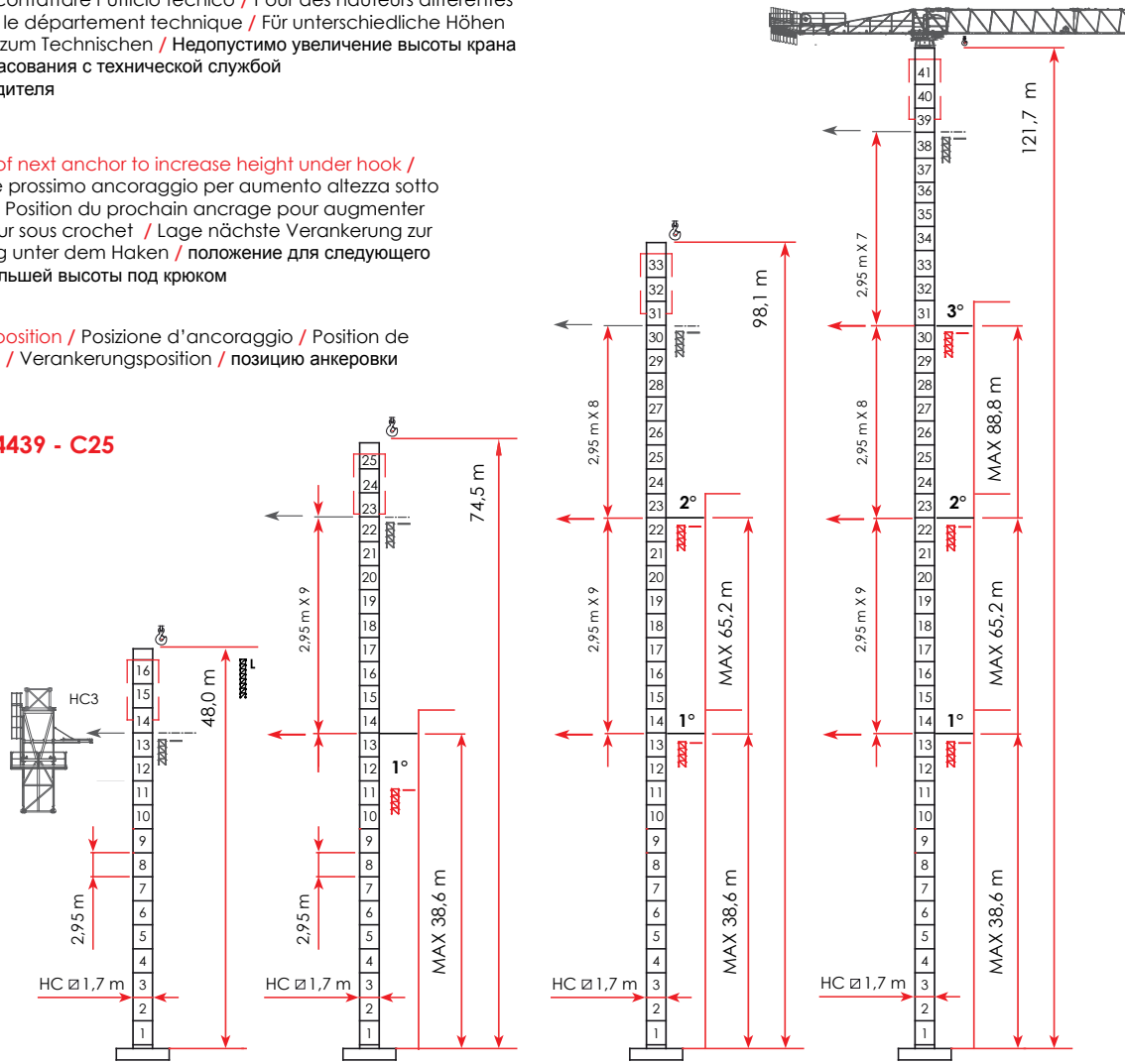



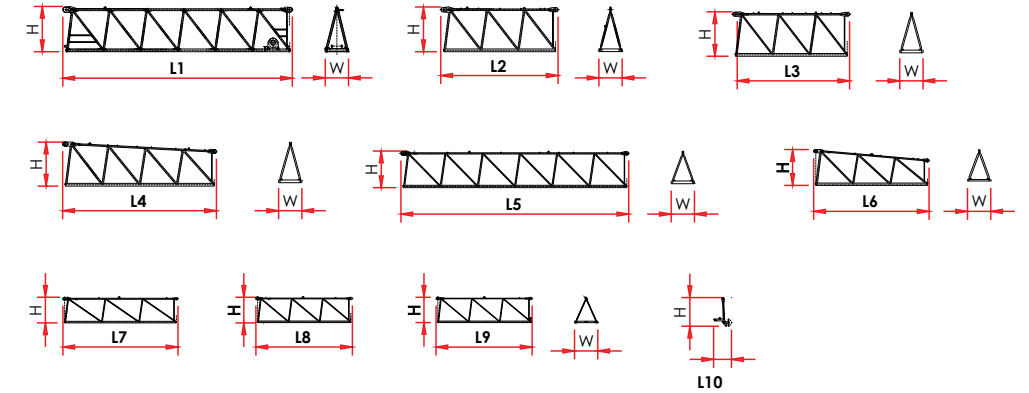





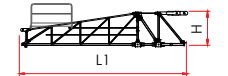

### Jib element









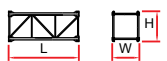

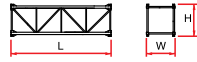

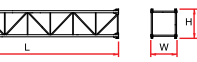

### Description

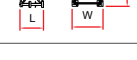
Elemento freccia / Élément de flèche / Auslegerelement jib section / Секция стрелы

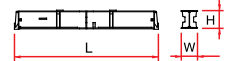
Item n.	Pz n°	Dimension ( m )			Weight ( kg )	
		l	w	h	Unit	Total
<b>L1</b>	1	11,84	1,20	2,30	2813	-
<b>L2</b>	1	6,04	1,20	2,30	962	-
<b>L3</b>	1	6,03	1,20	2,28	786	-
<b>L4</b>	1	7,93	1,20	2,26	982	-
<b>L5</b>	1	11,8	1,20	1,88	1076	-
<b>L6</b>	1	5,95	1,20	1,85	501	-
<b>L7</b>	1	5,93	1,20	1,32	397	-
<b>L8</b>	1	4,96	1,20	1,30	258	-
<b>L9</b>	1	4,95	1,20	1,30	237	-
<b>L10</b>	1	0,93	1,20	1,48	86	-

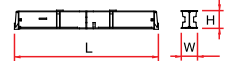
Description	Item	Pz	Drawing	Dimension ( m )			Weight ( kg )		
				n.	n°	l	w	h	Unit
<b>Counterjib - tournable, hoisting winch, trolley jib, electrical box, terminal element / Controfreccia - girevole, argano sollevamento, quadro elettrico, carrello freccia, portablocchi / Contreflèche tournante, treuil de levage, chariot de flèche, armoire électrique, élément terminal / Gegenausleger, Hubwinde, Laufkatze, Schaltschrank, Element für Gegengewichts Blöcke anführen / Консоль с поворотным кругом, лебедка, тележка, эл. ящик, противовесная консоль</b>	1			16,4	2,36	2,38	-	7560	
				<b>L1</b> 11,00	1,25	2,38	-	3850	
	<b>2</b>			<b>L2</b> 2,64	2,16	1,95	-	2700	
				<b>L3</b> 3,56	2,36	1,95	-	1010	
<b>Access balcony, cabin / Ballatoio cabina, cabina / Porte cabine / Kabine Podest, Kabine / Платформа кабины, кабина</b>	3	1		<b>L4</b> 3,70	2,13	2,26	-	1300	
				<b>L5</b> 3,45	3,75	2,28	-	4600	
<b>Counterweight block / Blocchi di contrappeso / Contre - poids / Gegengewichts Blöcke / Блоки противовеса</b>	8			<b>A MRT159</b>	1,300	0,300	3,00	2023	-
	<b>4</b>	1		<b>B MRT159</b>	1,300	0,200	3,00	1357	-
		1		<b>C MRT159</b>	1,300	0,250	3,00	1695	-
<b>Tower element / Elementi di torre / Elément de mature / Turmstück / Башенные секции</b>	5			<b>CITY 1,5</b>	2,95	1,500	1,700	1400	-
				<b>CITY 1,7</b>	2,95	1,900	1,700	1350	-
<b>6</b>			<b>HC3 - 1,7</b>	2,95	1,850	1,850	950	-	
	<b>7</b>			<b>CITY 1,5</b>	4,425	1,700	1,500	1642	-

Description	Item	Pz	Drawing	Dimension ( m )			Weight ( kg )			
				n.	n°	l	w	h	Unit	Total
<b>Tower element / Elementi di torre / Elément de mature / Turmstück / Башенные секции</b>	8			<b>TP 1715</b>	5,90	1,900	1,700	2245	-	
				<b>CITY 1,5</b>	5,90	1,500	1,700	2070	-	
	9			<b>CITY 1,7</b>	5,90	1,900	1,700	2295	-	
		<b>10</b>			<b>HC3 - 1,7</b>	5,90	1,850	1,850	1695	-
	11			<b>CITY 1,5</b>	11,80	1,500	1,700	3870	-	
				<b>CITY 1,7</b>	11,80	1,900	1,700	4175	-	
	12			<b>HC3 - 1,7</b>	11,80	1,850	1,850	3235	-	
		1			<b>CITY 1,5</b>	1,465	1,780	1,780	795	-
	13			<b>CITY 1,7</b>	1,465	1,980	1,980	830	-	
		<b>14</b>	1		<b>HC3 - 1,7</b>	1,325	1,960	1,960	624	-
	<b>Expendable foundation element / Tronchetto di fondazione / Elément a sceller / Fundamentanker / Анкер</b>	15			<b>CITY 1,5 4,5 x 4,5 m</b>	6,530	0,710	0,760	2450	-
					<b>CITY 1,7 4,5 x 4,5 m</b>	6,524	0,780	0,960	2595	-
				<b>HC3 - 1,7 4,5 x 4,5 m</b>	6,530	0,710	0,760	2450	-	
<b>Base main beam / Trave principale crosiera di base / Poutre de chassis de base / Haupt-träger für Kreuzbase / Главная балка крестовины основания</b>	15			<b>CITY 1,5 4,5 x 4,5 m</b>	6,530	0,710	0,760	2450	-	
				<b>CITY 1,7 4,5 x 4,5 m</b>	6,524	0,780	0,960	2595	-	

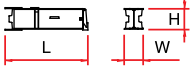
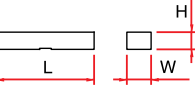
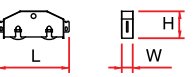
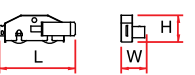
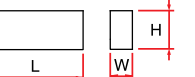
Description	Item	Pz	Drawing	Dimension ( m )			Weight ( kg )				
				n.	n°	l	w	h	Unit	Total	
Half base beam / Semitrave di base / Semipoutre de chassis de base / Halb-träger für Kreuzbase / Полубалка основания	16	2		CITY 1,5 4,5 x 4,5 m			3,200	0,590	0,770	1090	2180
				CITY 1,7 4,5 x 4,5 m			3,212	0,680	0,974	1235	2470
				HC3 - 1,7			3,200	0,590	0,770	1090	2180
Concrete pad / Blocco di appoggio / Sabot en béton / Beton Fuß / Опорный блок	17	4		CITY 1,5 B2			3,600	0,800	0,600	3925	15700
				HC3 - 1,7 B2			3,600	0,800	0,600	3925	15700
Driving bogie / Bilancino di traslazione folle / Boggie fou / Schaukel Bewegung - Neutralstellung / Не приводной балансир	18	2		CITY 1,5			1,080	0,230	0,515	415	830
				HC3 - 1,7			1,080	0,230	0,515	415	830
Driven bogie / Bilancino di traslazione motorizzato / Boggie motorisée / Schau- kel Bewegung - Betriebsene / Приводной балансир	19	2		CITY 1,5			1,550	0,500	0,515	535	1070
				HC3 - 1,7			1,550	0,500	0,515	535	1070
Base ballast block / Blocco di zavorra / Lest de base / Grundballast / блок балласта	20	-		GB3			3,600	1,200	0,300	2950	-

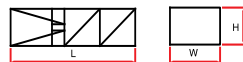
Description	Item	Pz	Drawing	Dimension ( m )			Weight ( kg )				
				n.	n°	l	w	h	Unit	Total	
Climbing cage connection frame / Telaio di raccordo a spinta / Elèment de telescopage / Verbindungsrahmen und drücken / Переходной элемент	21			HC3 - 1,7			1,500	1,970	1,970	690	-
				GR3 - 1,7			7,160	2,530	2,390	4200	-
Climbing Cage / Gabbia di montaggio / Semipoutre de chassis de base / Montagekäfig	22			GR3 - 1,7			7,160	2,530	2,390	4200	-



3 x 13,60 m  
1 x 10,00 m

MRT159 \_Jib 65 m • HUH 0,0 m

Top part / Parte rotante / Partie tournante / Drehender Kranteil / Поворотная часть



4 x 40 High cube  
1 x 40 Open Top

Included counter weight and cabin / Cabina e contrappesi inclusi / Cabine et  
contrepois inclus / Kabine und Gegengewichts Blöcke – inbegriffen / Противовес  
включен - кабина





The Raimondi MRT189 topless tower crane on a Kalyon Construction jobsite in Istanbul, Turkey, erected by AKEM Group. This tower crane guarantees easy, safe and comfortable access to all main systems: winches, pulleys, electrical cabin, and safety devices

# MRT189

## 10t

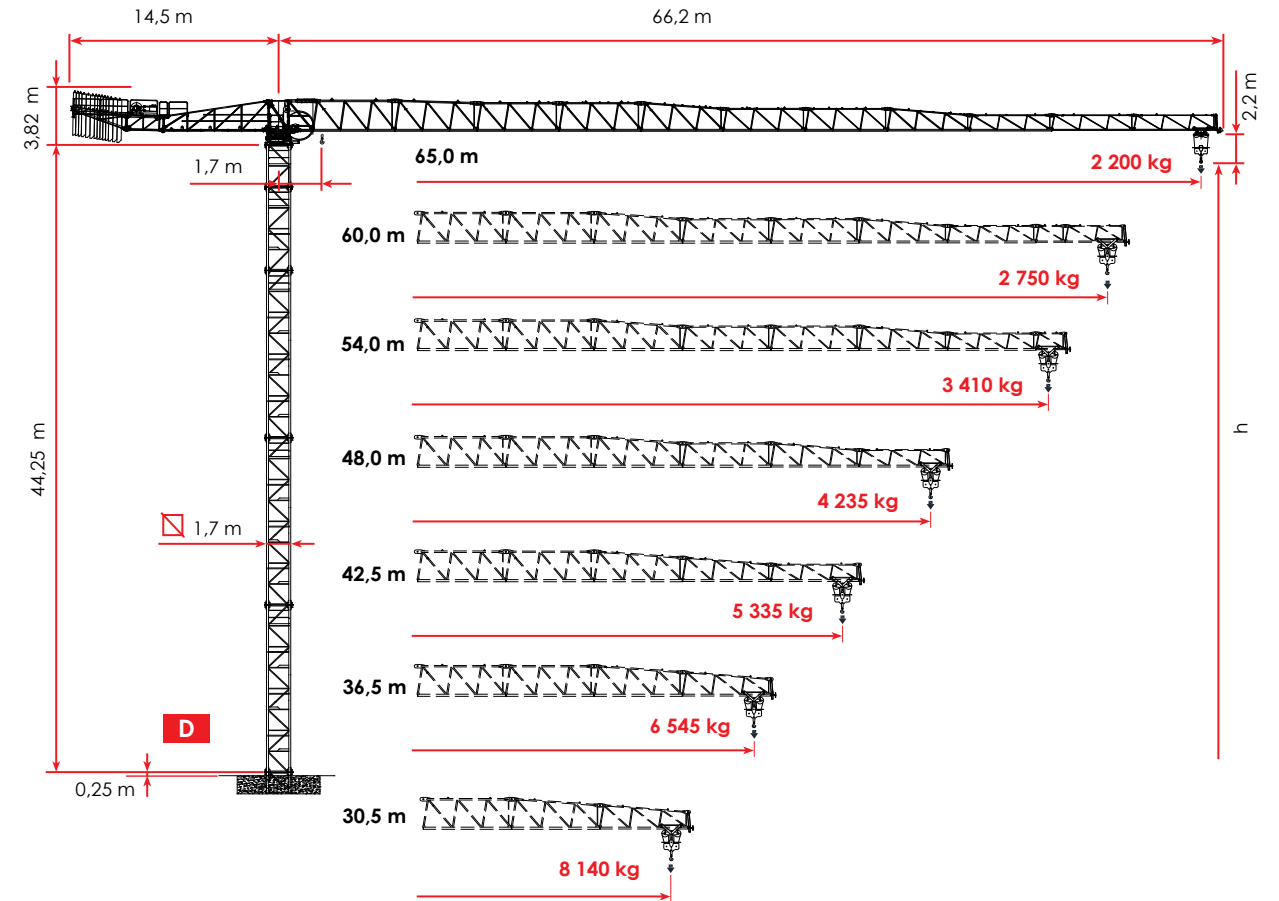

**D** h 43,3 m C25  
h 43,3 m D25  
h 43,3 m FEM 1.001

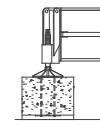

**A** 4,5 x 4,5 m  
h 45,1 m C25  
h 45,1 m D25  
h 45,1 m FEM 1.001

   2000/14/CE  
A4 EN 14439 C25 D25 - FEM 1.001

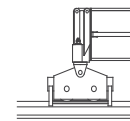



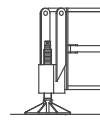











**B** 4,5 x 4,5 m  
h 44,7 m C25  
h 44,7 m D25  
h 44,7 m FEM 1.001





**E** 4,5 x 4,5 m  
h 44,4 m C25  
h 44,4 m D25  
h 44,4 m FEM 1.001

 **RAIMONDI**® MRT189  
SINCE 1863

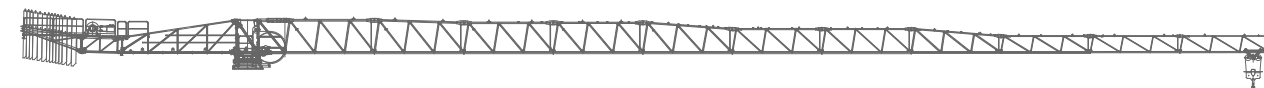
IT	EN	F	DE	RU
 Altezza sotto gancio	Height under hook	Hauteur sous crochet	Höhe unter dem Haken	Высота под крюком
 Contrappesi	Counter weight jib ballast	Lest de contre-flèche	Gegenauslegerballast	Противовесы
 Freccia	Jib	Flèche	Kranarm	стрела крана
 Carico massimo	Max load	Charge maximale	Maximale Belastung	максимальная нагрузка
 Curva di carico Ultralift	Load diagrams with ultralift control	Courbes de charges Ultralift	Lastkurven Ultralift	Кривой Груз Ultralift
 Altezza libera	Free Standing	Hauteur libre	Freistehend	Свободностоящая высота
 Azionamenti	Mechanisms	Mécanismes	Antriebe	Приводы
 Velocità	Speed	Vitesse	Geschwindigkeit	скорость
<b>4* - 5*</b>  Marce con velocità proporzionale al carico	5 step with speed proportional to the load	5 rapports avec une vitesse proportionnelle à la charge	5 Gang Geschwindigkeit proportional zum Last	Автоматический выбор скорости механизма подъема в зависимости от величины груза
 Tiro a 2 funi	Two - rope pull	Tir à deux câbles	Zug an zwei Seilen	Двукратная запасовка тросов
 Tiro a 4 funi	Four - rope pull	Tir à quatre câbles	Zug an vier Seilen	Четырехкратная запасовка тросов
 Totale metri fune tamburo	Total meters rope drum	Total des mètres de corde du tambour	Total Meter Seil Trommel	Запас троса на барабане в метрах
 Diametro fune	Rope diameter	Diamètre du câble	Seildurchmesser	Диаметр троса
 Rotazione	Slewing	Orientation	Schwenken	Поворот
 Carrello	Trolley	Chariot	Katzfahren	Тележка



			MAX 	25,0 m	30,5 m	36,5 m	42,5 m	48,0 m	54,0 m	60,0 m	65,0 m
kg	m	10,0 t	†								
22 994	<b>65,0</b>	19,0 m	7,29	5,78	4,66	3,86	3,31	2,83	2,46	<b>2,20</b>	
21 637	<b>60,0</b>	20,5 m	7,99	6,35	5,14	4,27	3,67	3,16	<b>2,75</b>		
20 280	<b>54,0</b>	21,8 m	8,54	6,80	5,51	4,59	<b>3,95</b>	<b>3,41</b>			
18 257	<b>48,0</b>	22,9 m	9,08	7,24	5,88	4,91	<b>4,23</b>				
16 900	<b>42,5</b>	24,6 m	9,81	7,84	6,37	<b>5,33</b>					
15 543	<b>36,5</b>	25,1 m	10,0	8,04	<b>6,54</b>						
13 520	<b>30,5</b>	25,4 m	10,0	<b>8,14</b>							
10 806	<b>25,0</b>	25,0 m	<b>10,0</b>								

 400 V ± 5% 50 Hz

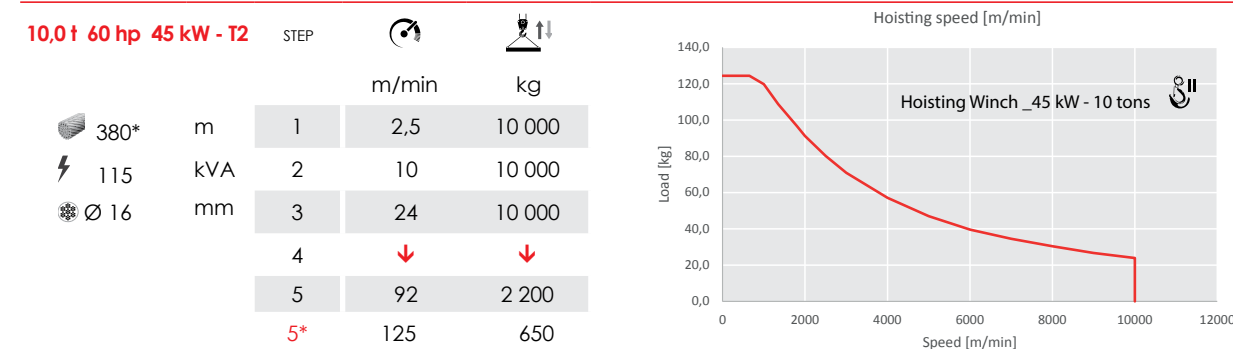
 2005 / 88 / CE

kVA Power required / Potenza richiesta / Puissance requise / Erforderliche Leistung / Потребляемая мощность

\* Rope Length 485m on demand / Su richiesta lunghezza della fune 485 m

 0,37/0,7/1,0 min<sup>-1</sup> • 2 x 4 kW /  15,0/42,0/67,0/ 75,0 (†) m/min • 5,5 kW /  19 m/min • 4 x 2,9 kW



 400 V ± 5% 50 Hz

 2005 / 88 / CE

**10,0 t 60 hp 45 kW - T4**



STEP



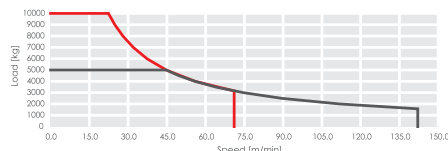

		m/min	kg	m/min	kg
 660 m		0		0	
 95 kVA	1	↓	↓	↓	↓
 Ø 14 mm	2	45	5000	22,5	10000
	3	↓	↓	↓	↓
	4	75	2500	37,5	5000
	5	↓	↓	↓	↓
	5*	136	1000	68	2000



\* **Speed automatically controlled by a current sensor** / Velocità regolata automaticamente da sensore di corrente / Vitesse réglée automatiquement par capteur de courant / Automatisch durch Stromsensor geregelte geschwindigkeit / СКОРОСТЬ АВТОМАТИЧЕСКИ КОНТРОЛИРУЕТСЯ ДАТЧИКОМ НАПРЯЖЕНИЯ

 0,37/0,7/1,0 min<sup>-1</sup> • 2 x 4 kW /  15,0/42,0/67,0/ 75,0 (°) m/min • 5,5 kW /  19 m/min • 4 x 2,9 kW

	JIB	25	30,5	36,5	42,5	48	54	60	65
 1,7m ▶		25,0	25,4	25,1	24,6	22,9	21,8	20,5	19,0
17		10 000	10 000	10 000	10 000	10 000	10 000	10 000	10 000
18		10 000	10 000	10 000	10 000	10 000	10 000	10 000	10 000
20		10 000	10 000	10 000	10 000	10 000	10 000	10 000	9 410
23		10 000	10 000	10 000	10 000	9 983	9 391	8 793	8 024
<b>25</b>		<b>10 000</b>	10 000	10 000	9 819	9 088	8 544	7 996	7 291
28			8 967	8 860	8 642	7 991	7 507	7 020	6 391
<b>30,5</b>			<b>8 140</b>	8 042	7 843	7 246	6 803	6 356	5 780
34				7 103	6 925	6 391	5 994	5 594	5 079
<b>36,5</b>				<b>6 545</b>	6 379	5 882	5 513	5 141	4 662
40					5 731	5 279	4 943	4 604	4 167
<b>42,5</b>					<b>5 335</b>	4 910	4 594	4 275	3 865
43						4 841	4 529	4 214	3 809
<b>48</b>						<b>4 235</b>	3 956	3 674	3 312
<b>54</b>							<b>3 410</b>	3 160	2 838
58								2 877	2 578
<b>60</b>								<b>2 750</b>	2 461
<b>65</b>									<b>2 200</b>

	JIB	25	30,5	36,5	42,5	48	54	60	65
 1,7m ▶		25,0	25,4	25,1	24,6	22,9	21,8	20,5	19,0
17		10 000	10 000	10 000	10 000	10 000	10 000	10 000	10 000
18		10 000	10 000	10 000	10 000	10 000	10 000	10 000	10 000
20		10 000	10 000	10 000	10 000	10 000	10 000	10 000	9 410
23		10 000	10 000	10 000	10 000	9 983	9 391	8 793	8 024
<b>25</b>		<b>10 000</b>	10 000	10 000	9 819	9 088	8 544	7 996	7 291
28			8 967	8 860	8 642	7 991	7 507	7 020	6 391
<b>30,5</b>			<b>8 140</b>	8 042	7 843	7 246	6 803	6 356	5 780
34				7 103	6 925	6 391	5 994	5 594	5 079
<b>36,5</b>				<b>6 545</b>	6 379	5 882	5 513	5 141	4 662
40					5 731	5 279	4 943	4 604	4 167
<b>42,5</b>					<b>5 335</b>	4 910	4 594	4 275	3 865
43						4 841	4 529	4 214	3 809
<b>48</b>						<b>4 235</b>	3 956	3 674	3 312
<b>54</b>							<b>3 410</b>	3 160	2 838
58								2 877	2 578
<b>60</b>								<b>2 750</b>	2 461
<b>65</b>									<b>2 200</b>

**ULTRALIFT** If the crane is not equipped with Ultralift control, all intermediate loads are decreased by 10% / Senza il sistema Ultralift tutte le portate intermedie diminuiscono il carico del 10% / Les charges intermediaires sont diminuées de 10% si la grue n'est pas équipée d'un controle Ultralift. / Mit dem ULTRALIFT-System erhöhen alle Zwischenbelastbarkeiten die Last um 10% / Без ULTRALI FT промежуточный вес уменьшается на 10%.

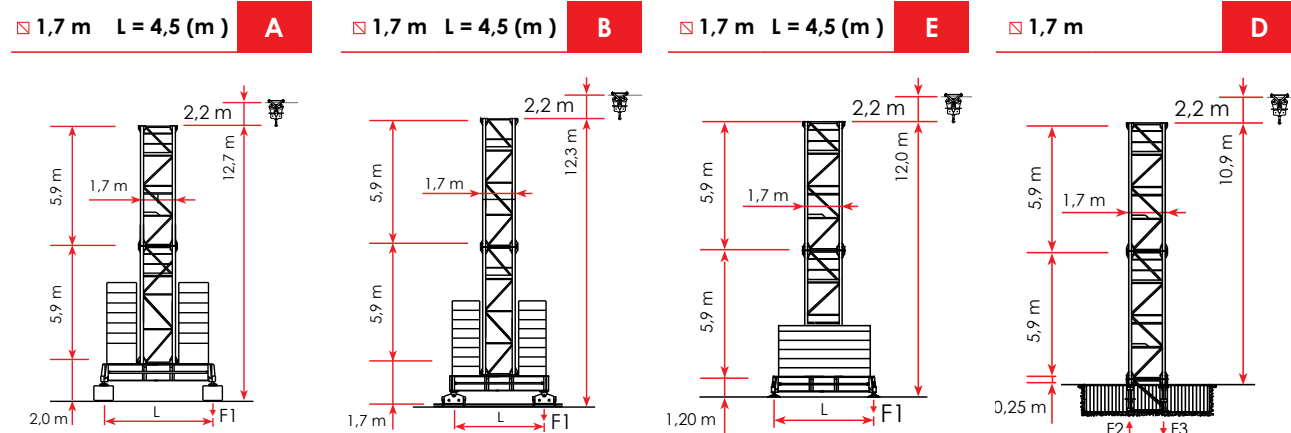

A																				
1,7 m					L = 4,5 m															
EN 14439 - C25					EN 14439 - D25					FEM 1.001										
$\Delta H$ (m)	H (m)	Z** (t)	F1 (kN)		$\Delta H$ (m)	H (m)	Z** (t)	F1 (kN)		$\Delta H$ (m)	H (m)	Z** (t)	F1 (kN)		$\Delta H$ (m)	H (m)	Z** (t)	F1 (kN)		
7	-	-	-	-	7	-	-	-	-	7	-	-	-	-						
6	2,95 m	45,1	104,7	794	6	2,95 m	45,1	110,6	958	6	2,95 m	45,1	104,7	754						
5	5,9 m	42,2	98,8	763	5	5,9 m	42,2	98,8	797	5	5,9 m	42,2	98,8	725						
4	5,9 m	36,3	92,9	705	4	5,9 m	36,3	98,8	720	4	5,9 m	36,3	92,9	670						
3	5,9 m	30,4	92,9	673	3	5,9 m	30,4	92,9	673	3	5,9 m	30,4	92,9	639						
2	5,9 m	24,5	87,0	629	2	5,9 m	24,5	87,0	629	2	5,9 m	24,5	87,0	598						
+1	5,9 m	18,6	81,1	590	+1	5,9 m	18,6	81,1	594	+1	5,9 m	18,6	81,1	560						

- |          |                       |                           |                          |                              |                            |
|----------|-----------------------|---------------------------|--------------------------|------------------------------|----------------------------|
| <b>A</b> | Base on concrete pads | Base su zatteroni         | Grue sur blocs d'appui   | Kran auf Stützblöcken        | Кран на опорных блоках     |
| <b>B</b> | Travelling base       | Base traslante            | Grue à traslation        | Fahrbarer Kran               | Кран передвижной           |
| <b>E</b> | Base on steel pads    | Base con piedi regolabili | Grue sur pieds réglables | Kran auf verstellbaren Füßen | Кран на регулируемых лапах |
| <b>D</b> | Crane on embedded     | Gru su tronchetto         | Grue sur plinthe         | Kran auf Fundamentplatte     | Кран на фундаменте         |

B																				
1,7 m					L = 4,5 m										STANDARD 1,7 CITY - 10t					
EN 14439 - C25					EN 14439 - D25					FEM 1.001										
$\Delta H$ (m)	H (m)	Z** (t)	F1 (kN)		$\Delta H$ (m)	H (m)	Z** (t)	F1 (kN)		$\Delta H$ (m)	H (m)	Z** (t)	F1 (kN)		$\Delta H$ (m)	H (m)	Z** (t)	F1 (kN)		
7	-	-	-	-	7	-	-	-	-	7	-	-	-	-						
6	2,95 m	44,7	100,3	790	6	2,95 m	44,7	106,2	968	6	2,95 m	44,7	100,3	750						
5	5,9 m	41,8	94,4	759	5	5,9 m	41,8	94,4	806	5	5,9 m	41,8	94,4	721						
4	5,9 m	35,9	88,5	701	4	5,9 m	35,9	94,4	717	4	5,9 m	35,9	88,5	666						
3	5,9 m	30,0	88,5	668	3	5,9 m	30,0	88,5	670	3	5,9 m	30,0	88,5	635						
2	5,9 m	24,1	82,6	625	2	5,9 m	24,1	82,6	626	2	5,9 m	24,1	82,6	594						
+1	5,9 m	18,2	76,7	586	+1	5,9 m	18,2	76,7	591	+1	5,9 m	18,2	76,7	557						

E																				
1,7 m					L = 4,5 m															
EN 14439 - C25					EN 14439 - D25					FEM 1.001										
$\Delta H$ (m)	H (m)	Z** (t)	F1 (kN)		$\Delta H$ (m)	H (m)	Z** (t)	F1 (kN)		$\Delta H$ (m)	H (m)	Z** (t)	F1 (kN)		$\Delta H$ (m)	H (m)	Z** (t)	F1 (kN)		
7	-	-	-	-	7	-	-	-	-	7	-	-	-	-						
6	2,95 m	44,4	100,3	781	6	2,95 m	44,4	106,2	935	6	2,95 m	44,4	100,3	742						
5	5,9 m	41,5	94,4	751	5	5,9 m	41,5	94,4	775	5	5,9 m	41,5	94,4	713						
4	5,9 m	35,6	88,5	693	4	5,9 m	35,6	94,4	708	4	5,9 m	35,6	88,5	658						
3	5,9 m	29,7	88,5	660	3	5,9 m	29,7	88,5	660	3	5,9 m	29,7	88,5	627						
2	5,9 m	23,8	82,6	617	2	5,9 m	23,8	82,6	617	2	5,9 m	23,8	82,6	587						
+1	5,9 m	17,9	76,7	578	+1	5,9 m	17,9	76,7	583	+1	5,9 m	17,9	76,7	549						

**Z\*\***  **Comply with the specified ballast Z(t) / Attenersi alla zavorra indicata Z(t) / S'en tenir au lest indiqué Z(t) / Unbedingt die angegebenen Ballastwerte einhalten Z(t) / Соблюдать указанный балласт Z(t)**



**D** 1,7 m **STANDARD 1,7 CITY - 10t**

EN 14439 - C25					EN 14439 - D25					FEM 1.001				
$\Delta H$ (m)	H (m)	F2 (kN)	F3 (kN)		$\Delta H$ (m)	H (m)	F2 (kN)	F3 (kN)		$\Delta H$ (m)	H (m)	F2 (kN)	F3 (kN)	
7	-	-	-	-	7	-	-	-	-	7	-	-	-	-
6	2,95 m	43,3	1235	936	6	2,95 m	43,3	1406	1093	6	2,95 m	43,3	1173	890
5	5,9 m	40,4	1174	887	5	5,9 m	40,4	1181	887	5	5,9 m	40,4	1116	842
4	5,9 m	34,5	1073	803	4	5,9 m	34,5	1073	803	4	5,9 m	34,5	1019	763
3	5,9 m	28,6	985	732	3	5,9 m	28,6	985	732	3	5,9 m	28,6	936	695
2	5,9 m	22,7	911	673	2	5,9 m	22,7	911	673	2	5,9 m	22,7	866	640
+1	5,9 m	16,8	853	626	+1	5,9 m	16,8	853	626	+1	5,9 m	16,8	810	594

**B** HC5S 2,1m L = 6,0 m **STANDARD 2,1 HC5S - 10t**

EN 14439 - C25					EN 14439 - D25					FEM 1.001				
$\Delta H$ (m)	H* (m)	Z** (t)	F1 (kN)		$\Delta H$ (m)	H* (m)	Z** (t)	F1 (kN)		$\Delta H$ (m)	H* (m)	Z** (t)	F1 (kN)	
7	-	-	-	-	7	-	-	-	-	7	-	-	-	-
6	2,95m	60,8	102,9	1240	6	-	-	-	-	6	2,95m	60,8	96,5	1132
5	5,9 m	57,9	90,0	1102	5	2,95m	54,9	116	1342	5	5,9 m	57,9	83,5	1011
4	5,9 m	52,0	77,1	853	4	5,9 m	52,0	97	1181	4	5,9 m	52,0	77,1	793
3	5,9 m	46,1	64,2	641	3	5,9 m	46,1	77	896	3	5,9 m	46,1	70,6	646
2	5,9 m	40,2	57,7	583	2	5,9 m	40,2	64	655	2	5,9 m	40,2	64,2	599
+1	5,9 m	34,3	44,8	532	+1	5,9 m	34,3	58	554	+1	5,9 m	34,3	64,2	576

**STANDARD 2,1 HC5S - 10T**

**B** 2,1 m L = 6,0 (m) **E** 2,1 m L = 6,0 (m) **D** 2,1 m **D** 2,1 m Booster

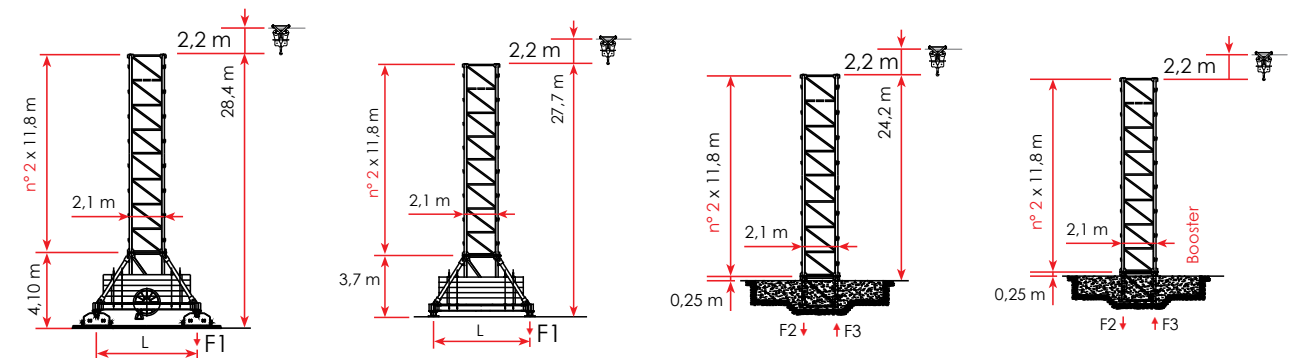

<b>B</b> Travelling base	Base traslante	Grue à traslation	Fahrbarer Kran	Кран передвижной
<b>E</b> Base on steel pads	Base con piedi regolabili	Grue sur pieds réglables	Kran auf verstellbaren Füßen	Кран на регулируемых лапах
<b>D</b> Crane on embedded	Gru su tronchetto	Grue sur plinthe	Kran auf Fundamentplatte	Кран на фундаменте

**E** HC5S 2,1m L = 6,0 m

EN 14439 - C25					EN 14439 - D25					FEM 1.001				
$\Delta H$ (m)	H* (m)	Z** (t)	F1 (kN)		$\Delta H$ (m)	H* (m)	Z** (t)	F1 (kN)		$\Delta H$ (m)	H* (m)	Z** (t)	F1 (kN)	
7	-	-	-	-	7	-	-	-	-	7	-	-	-	-
6	2,95m	60,1	102,9	1211	6	-	-	-	-	6	2,95m	60,1	94,5	1109
5	5,9 m	57,2	90,0	1075	5	2,95m	54,2	116	1307	5	5,9 m	57,2	83,5	990
4	5,9 m	51,3	77,1	829	4	5,9 m	51,3	97	1148	4	5,9 m	51,3	77,1	774
3	5,9 m	45,4	64,2	620	3	5,9 m	45,4	77	868	3	5,9 m	45,4	70,6	636
2	5,9 m	39,5	57,7	574	2	5,9 m	39,5	64	631	2	5,9 m	39,5	64,2	589
+1	5,9 m	33,6	44,8	523	+1	5,9 m	33,6	58	545	+1	5,9 m	33,6	64,2	566

**Z\*\***  **Comply with the specified ballast Z(t) / Attenersi alla zavorra indicata Z(t) / S'en tenir au lest indiqué Z(t) / Unbedingt die angegebenen Ballastwerte einhalten Z(t) / Соблюдать указанный балласт Z(t)**

**D** **HC5S 2,1m** **STANDARD 2,1 HC5S - 10t**

EN 14439 - C25					EN 14439 - D25					FEM 1.001				
$\Delta H$ (m)	H* (m)	F2 (kN)	F3 (kN)		$\Delta H$ (m)	H* (m)	F2 (kN)	F3 (kN)		$\Delta H$ (m)	H* (m)	F2 (kN)	F3 (kN)	
7	-	-	-	-	7	-	-	-	-	7	-	-	-	-
6	2,95m	56,6	1800	1428	6	-	-	-	-	6	2,95m	56,6	1752	1375
5	5,9 m	53,7	1601	1238	5	2,95m	50,7	1887	1530	5	5,9 m	53,7	1565	1202
4	5,9 m	47,8	1239	889	4	5,9 m	47,8	1662	1313	4	5,9 m	47,8	1225	877
3	5,9 m	41,9	989	680	3	5,9 m	41,9	1253	919	3	5,9 m	41,9	992	678
2	5,9 m	36,0	909	618	2	5,9 m	36,0	909	618	2	5,9 m	36,0	914	615
+1	5,9 m	30,1	839	565	+1	5,9 m	30,1	839	565	+1	5,9 m	30,1	846	561

**D** **HC5S 2,1m** **BOOSTER**

EN 14439 - C25					EN 14439 - D25					FEM 1.001				
$\Delta H$ (m)	H* (m)	F2 (kN)	F3 (kN)		$\Delta H$ (m)	H* (m)	F2 (kN)	F3 (kN)		$\Delta H$ (m)	H* (m)	F2 (kN)	F3 (kN)	
8	2,95 m	65,5	2486	2095	8	-	-	-	-	8	2,95 m	65,5	2366	1976
7					7	2,95 m	59,6	2671	2294	7				
6					6					6				
5					5					5				
4					4					4				
3					3					3				
2					2					2				
+1					+1					+1				

**H\*** Climbing cage connection frame including / Telaio di raccordo a spinta incluso / Elément de telescopage compris / Включая соединительную раму подъемной клетки

 For different heights contact the technical department / Per altezze diverse contattare l'ufficio tecnico / Pour des hauteurs différentes contact le département technique / Für unterschiedliche Höhen Kontakt zum Technischen / Недопустимо увеличение высоты крана без согласования с технической службой производителя

 Position of next anchor to increase height under hook / Posizione prossimo ancoraggio per aumento altezza sotto gancio / Position du prochain ancrage pour augmenter la hauteur sous crochet / Lage nächste Verankerung zur Erhöhung unter dem Haken / положение для следующего якоря большей высоты под крюком







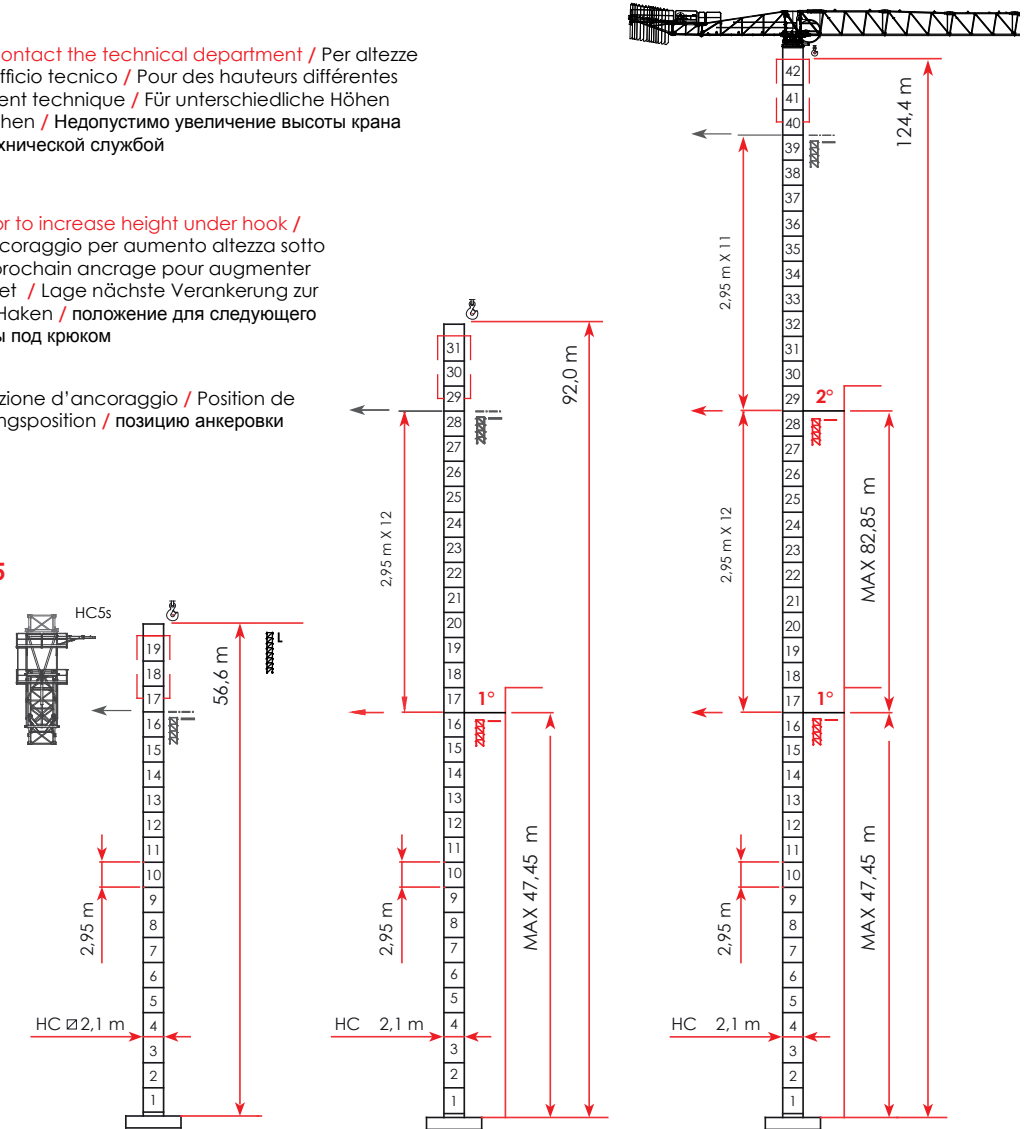

 Anchor position / Posizione d'ancoraggio / Position de ancrage / Verankerungsposition / позицию анкеровки

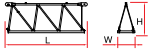
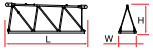
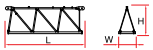

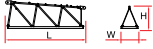

 **FEM 1.001**

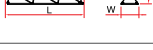
**EN 14439 - C25**

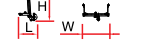

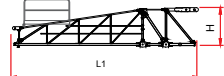

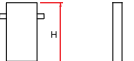

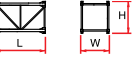
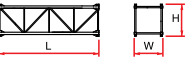
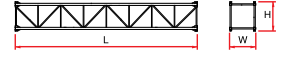
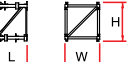
Climbing crane / Sopralzo idraulico / Téliscopage sur dalles / Kletterkrane im Gebäude / Кран поднимающийся на плитах перекрытия

Description	Item	Pz	Drawing	Dimension ( m )			Weight ( kg )	
				n.	n°	l	w	h
<b>Jib element</b>								
Elemento freccia	1	1		6,192	1,300	2,265	-	1520
Élément de flèche	2	2		6,187	1,300	2,265	-	1584
Auslegerelement jib section	3	3		6,158	1,300	2,100	-	1185
Секция стрелы	4	4		6,108	1,300	2,100	-	1145
	5	5		6,103	1,300	2,100	-	860
	6	6		6,099	1,300	1,680	-	785
	7	7		6,074	1,300	1,680	-	705
	8	8		6,064	1,300	1,660	-	630
	9	9		6,056	1,300	1,210	-	540
	10	10		5,986	1,300	1,170	-	361
	11	11		5,917	1,300	1,140	-	325
				924	1,330	1,303	-	110

Description	Item	Pz	Drawing	Dimension ( m )			Weight ( kg )		
				n.	n°	l	w	h	Unit
<b>Counterjib - tournable, hoisting winch, trolley jib, electrical box, terminal element</b> / Controfreccia - girevole, argano sollevamento, quadro elettrico, carrello freccia, portablocchi / Contreflèche tournante, treuil de levage, chariot de flèche, armoire électrique, élément terminal / Gegenausleger, Hubwinde, Laufkatze, Schaltschrank, Element für Gegengewichts Blöcke anführen / Консоль с поворотным кругом, лебедка, тележка, эл. ящик, противовесная консоль	1	1		16,90	2,30	2,36	-	8600	
	2	2		L1 10,80	1,60	2,30	-	4550	
				L2 2,70	2,21	1,94	-	2900	
				L3 4,00	2,26	2,22	-	1150	
	3	1		L4 3,60	2,13	2,26	-	1450	
				L5 3,70	4,79	2,62	-	5450	
	6			<b>A MRT 144</b>					
				1,300	0,30	3,00	2023	-	
	8			<b>B MRT 144</b>					
				1,300	0,20	3,00	1357	-	
	5	-		<b>CITY 1,7</b>					
				2,95	1,900	1,700	1349	-	
				<b>HC5s</b>					
				2,95	2,300	2,300	1900	-	
	6	-		<b>CITY 1,7</b>					
				5,90	1,900	1,700	2291	-	
				<b>HC5s</b>					
				5,90	2,300	2,300	3450	-	
	7	-		<b>CITY 1,7</b>					
				11,8	1,900	1,700	4171	-	
				<b>HC5s</b>					
				11,8	2,300	2,300	6240	-	
	8	1		<b>CITY 1,7</b>					
				1,465	1,98	1,98	830	-	
				<b>HC5s</b>					
				1,82	2,40	2,40	1370	-	

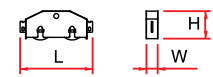
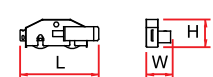

Description	Item	Pz	Drawing	Dimension ( m )			Weight ( kg )	
				n.	n°	l	w	h
<b>Base main beam</b> / Trave principale crosiera di base / Poutre de chassis de base / Haupt-träger für Kreuzbase / Главная балка крестовины основания	<b>9</b>	1		<b>4,5 x 4,5 m - 1,7m CITY</b>			2595	-
<b>Half base beam</b> / Semitrave di base / Semipoutre de chassis de base / Halb-träger für Kreuzbase / Полубалка основания	<b>10</b>	2		<b>4,5 x 4,5 m - 1,7m CITY</b>			1235	-
<b>Concrete pad</b> / Blocco di appoggio / Sabot en béton / Beton Fuß / Опорный блок	<b>11</b>	4		<b>B2</b>			5520	-
<b>Driving bogie</b> / Bilancino di traslazione folle / Boggie fou / Schaukel Bewegung - Neutralstellung / Не приводной балансир	<b>12</b>	2		1,315	0,230	0,540	600	-
<b>Driven bogie</b> / Bilancino di traslazione motorizzato / Boggie motoriseè / Schaukel Bewegung - Betriebene / Приводной балансир	<b>13</b>	2		1,427	0,492	0,540	765	-
<b>Base ballast block</b> / Blocco di zavorra / Lest de base / Grundballast / блок балласта	<b>14</b>	-		<b>GB3</b>			2950	-



4 x 13,60 m  
1 x 7,00 m

MRT189 \_Jib 65 m • HUH 0,0 m

Top part / Parte rotante / Partie tournante / Drehender Kranteil / Поворотная часть



4 x 40 High cube  
1 x 20 Box  
1 x 40 Open Top

Included counter weight and cabin / Cabina e contrappesi inclusi / Cabine et contrepoids inclus / Kabine und Gegengewichts Blöcke – inbegriffen / Противовес включен - кабина



As part of Raimondi's manufacturing tradition, excellence in end-user experience and ease of maintenance are two pillars the company has incorporated into its production techniques



# MRT234

## 12t



The Raimondi MRT234 topless tower crane erected in Milan, Italy

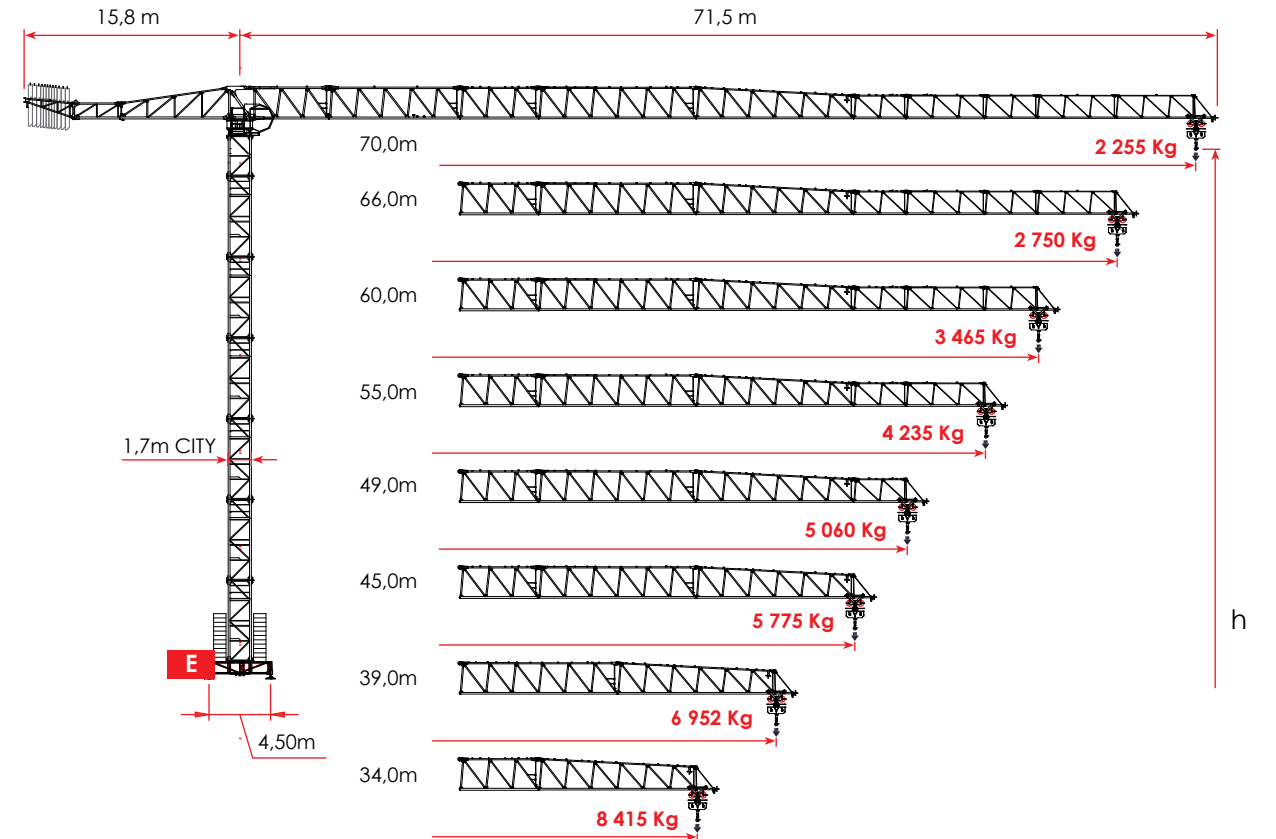

**D** -  
 h 37,5 m C25  
 h 37,5 m D25  
 h 40,4 m FEM 1.001















**A** 4,5 x 4,5 m  
 h 39,3 m C25  
 h 39,3 m D25  
 h 42,2 m FEM 1.001

**B** 4,5 x 4,5 m  
 h 39,1 m C25  
 h 39,1 m D25  
 h 42,0 m FEM 1.001



**E** 4,5 x 4,5 m  
 h 38,5 m C25  
 h 38,5 m D25  
 h 41,4 m FEM 1.001

 **RAIMONDI**® MRT234  
 SINCE 1863

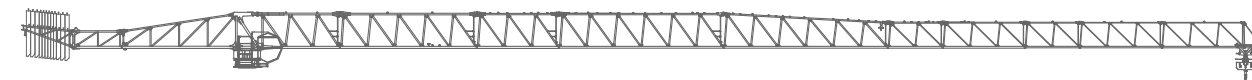

    
 2000/14/CE  
 A4 EN 14439 C25 D25 - FEM 1.001

IT	EN	F	DE	RU
 Altezza sotto gancio	Height under hook	Hauteur sous crochet	Höhe unter dem Haken	Высота под крюком
 Contrappesi	Counter weight jib ballast	Lest de contre-flèche	Gegenauslegerballast	Противовесы
 Freccia	Jib	Flèche	Kranarm	стрела крана
 Carico massimo	Max load	Charge maximale	Maximale Belastung	максимальная нагрузка
 Curva di carico Ultralift	Load diagrams with ultralift control	Courbes de charges Ultralift	Lastkurven Ultralift	Кривой Груз Ultralift
 Altezza libera	Free Standing	Hauteur libre	Freistehend	Свободностоящая высота
 Azionamenti	Mechanisms	Mécanismes	Antriebe	Приводы
 Velocità	Speed	Vitesse	Geschwindigkeit	скорость
<b>4* - 5*</b>  Marce con velocità proporzionale al carico	5 step with speed proportional to the load	5 rapports avec une vitesse proportionnelle à la charge	5 Gang Geschwindigkeit proportional zum Last	Автоматический выбор скорости механизма подъема в зависимости от величины груза
 Tiro a 2 funi	Two - rope pull	Tir à deux câbles	Zug an zwei Seilen	Двукратная запасовка тросов
 Tiro a 4 funi	Four - rope pull	Tir à quatre câbles	Zug an vier Seilen	Четырехкратная запасовка тросов
 Totale metri fune tamburo	Total meters rope drum	Total des mètres de corde du tambour	Total Meter Seil Trommel	Запас троса на барабане в метрах
 Diametro fune	Rope diameter	Diamètre du câble	Seildurchmesser	Диаметр троса
 Rotazione	Slewing	Orientation	Schwenken	Поворот
 Carrello	Trolley	Chariot	Katzfahren	Тележка



			MAX 	28 m	34,0 m	39,0 m	45,0 m	49,0 m	55,0 m	60,0 m	66,0 m	70,0 m
kg	m	12,0 t										
25 210	<b>70</b>	18,4 m	7 376	5 852	4 947	4 132	3 701	3 173	2 816	2 459	<b>2 255</b>	
23 955	<b>66</b>	19,8 m	8 074	6 424	5 444	4 561	4 095	3 524	3 137	<b>2 750</b>		
23 955	<b>60</b>	21,3 m	8 788	7 009	5 953	5 001	4 498	3 883	<b>3 465</b>			
23 955	<b>55</b>	22,8 m	9 489	7 584	6 453	5 433	4 894	<b>4 235</b>				
22 085	<b>49</b>	23,4 m	9 783	7 825	6 662	5 614	<b>5 060</b>					
20 830	<b>45</b>	23,9 m	10 044	8 039	6 848	<b>5 775</b>						
17 635	<b>39</b>	24,2 m	10 190	8 158	<b>6 952</b>							
15 765	<b>34</b>	24,9 m	10 503	<b>8 415</b>								
13 220	<b>28</b>	25,2 m	<b>10 670</b>									

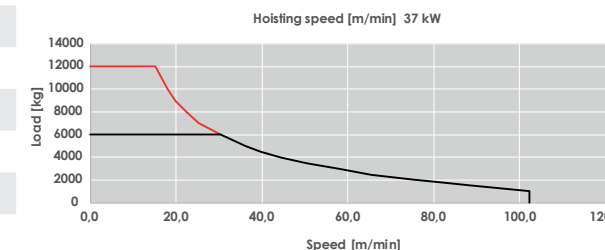

**12,0 t 50 hp 37 kW** STEP         400 V ± 5% 50 Hz  2000 / 14 / CE

		m/min	kg	m/min	kg
 330 m	1	4,5	12 000	9	6 000
 85 kVA	2	10,5	12 000	21	6 000
 Ø 14 mm	3	15,5	12 000	31	6 000
	4	↓	↓	↓	↓
	5	30	6 000	60	3 000
	<b>5*</b>	52	2 000	104	1 000



kVA Power required / Potenza richiesta / Puissance requise / Erforderliche Leistung / Потребляемая мощность

**\* Progressive speed automatically adjusted by the control system** / Velocità progressiva regolata automaticamente dal sistema di controllo / Vitesse progressive ajustée automatiquement par le système de contrôle / Progressive Geschwindigkeit automatisch durch das Steuersystem eingestellt.

 0,26/0,48/0,8 min<sup>-1</sup> • 2 x 80 Nm /  0 → 45 → 108 (°) m/min • 6,6 kW /  20 m/min • 2 x 4 kW

400 V ± 5% 50 Hz



2000 / 14 / CE

**12,0 t 75 hp 55 kW** STEP



	STEP	m/min	kg	m/min	kg
702 m	1	4,5	12 000	9	6 000
115 kVA	2	14	12 000	28	6 000
Ø 14 mm	3	22	12 000	44	6 000
	4	↓	↓	↓	↓
	5	42,5	6 000	85	3 000
	5*	60,0	2 000	120	1 000

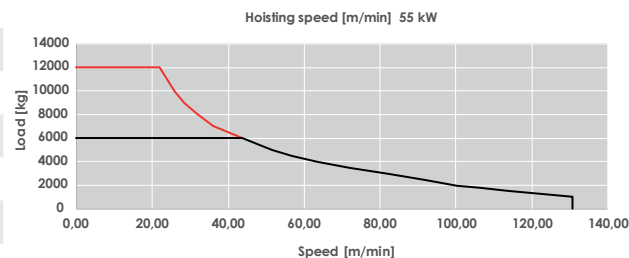



kVA Power required / Potenza richiesta / Puissance requise / Erforderliche Leistung / Потребляемая мощность

\* Progressive speed automatically adjusted by the control system / Velocità progressiva regolata automaticamente dal sistema di controllo / Vitesse progressive ajustée automatiquement par le système de contrôle / Progressive Geschwindigkeit automatisch durch das Steuersystem eingestellt.

0,26/0,48/0,8 min<sup>-1</sup> • 2 x 80 Nm / 0 → 45 → 108 (°) m/min • 6,6 kW / 20 m/min • 2 x 4 kW



JIB	28,0 m	34,0 m	39,0 m	45,0 m	49,0 m	55,0 m	60,0 m	66,0 m	70,0 m
18	25,2 m	24,9 m	24,2 m	23,9 m	23,4 m	22,8 m	21,3 m	19,8 m	18,4 m
19	12 000	12 000	12 000	12 000	12 000	12 000	12 000	12 000	11 541
21	12 000	12 000	12 000	12 000	12 000	12 000	12 000	11 235	10 295
22	12 000	12 000	12 000	12 000	12 000	12 000	11 572	10 655	9 760
23	12 000	12 000	12 000	12 000	12 000	11 863	11 003	10 128	9 274
24	12 000	12 000	12 000	11 957	11 650	11 306	10 484	9 647	8 829
26	11 600	11 420	11 082	10 925	10 642	10 326	9 569	8 798	8 045
28	10 670	10 503	10 190	10 044	9 783	9 489	8 788	8 074	7 376
30		9 712	9 420	9 284	9 041	8 767	8 114	7 448	6 798
32		9 022	8 749	8 622	8 394	8 138	7 526	6 903	6 295
34		8 415	8 158	8 039	7 825	7 584	7 009	6 424	5 852
36			7 635	7 522	7 320	7 093	6 551	5 999	5 459
38			7 167	7 061	6 870	6 655	6 142	5 619	5 109
39			6 952	6 848	6 662	6 453	5 953	5 444	4 947
42				6 273	6 100	5 906	5 443	4 971	4 510
44				5 933	5 768	5 584	5 142	4 692	4 252
45				5 775	5 614	5 433	5 001	4 561	4 132
46					5 466	5 290	4 867	4 437	4 017
48					5 190	5 021	4 616	4 204	3 802
49					5 060	4 894	4 498	4 095	3 701
50						4 773	4 385	3 990	3 604
53						4 438	4 072	3 700	3 336
54						4 335	3 976	3 610	3 253
55						4 235	3 883	3 524	3 173
56							3 793	3 441	3 097
57							3 707	3 361	3 023
58							3 623	3 283	2 951
59							3 543	3 209	2 882
60							3 465	3 137	2 816
63								2 934	2 629
64								2 871	2 570
65								2 809	2 513
66		+100Kg						2 750	2 459
68									2 354
70									2 255

MRT234 - 12,0t

**ULTRALIFT** If the crane is not equipped with Ultralift control, all intermediate loads are decreased by 10% / Senza il sistema Ultralift tutte le portate intermedie diminuiscono il carico del 10% / Les charges intermediaires sont diminuées de 10% si la grue n'est pas équipé d'un controle Ultralift. / Mit dem ULTRALIFT-System erhöhen alle Zwischenbelastbarkeiten die Last um 10% / Без ULTRALIFT промежуточный вес уменьшается на 10%.

1,7 m L = 4,5 (m) **A**

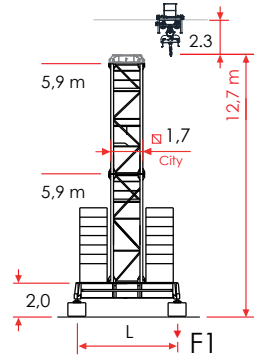

1,7 m L = 4,5 (m) **B**

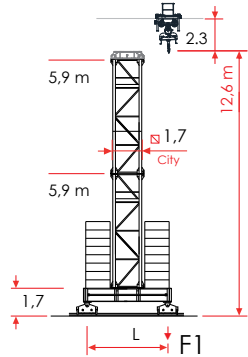

1,7 m L = 4,5 (m) **E**

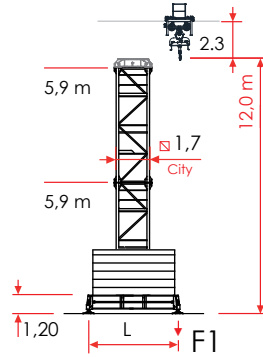

1,7 m **D**

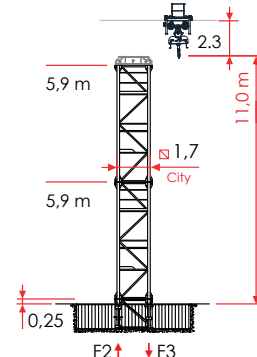

**A** 1,7 m L = 4,5 m

EN 14439 - C25				EN 14439 - D25				FEM 1.001			
$\Delta H$ (m)	H (m)	Z** (t)	F1 (kN)	$\Delta H$ (m)	H (m)	Z** (t)	F1 (kN)	$\Delta H$ (m)	H (m)	Z** (t)	F1 (kN)
7	-	-	-	7	-	-	-	7	-	-	-
6	-	-	-	6	2,95 m	42,2	113,9	6	2,95 m	42,2	829
5	2,95 m	39,3	800	5	2,95 m	39,3	113,9	5	2,95 m	39,3	800
4	5,9 m	36,3	753	4	5,9 m	36,3	103,7	4	5,9 m	36,3	753
3	5,9 m	30,4	675	3	5,9 m	30,4	93,5	3	5,9 m	30,4	675
2	5,9 m	24,5	633	2	5,9 m	24,5	83,3	2	5,9 m	24,5	633
+1	5,9 m	18,6	617	+1	5,9 m	18,6	83,3	+1	5,9 m	18,6	617

- |                                |                           |                          |                              |                            |
|--------------------------------|---------------------------|--------------------------|------------------------------|----------------------------|
| <b>A</b> Base on concrete pads | Base su zatteroni         | Grue sur blocs d'appui   | Kran auf Stützblöcken        | Кран на опорных блоках     |
| <b>B</b> Travelling base       | Base traslante            | Grue à traslation        | Fahrbarer Kran               | Кран передвижной           |
| <b>E</b> Base on steel pads    | Base con piedi regolabili | Grue sur pieds réglables | Kran auf verstellbaren Füßen | Кран на регулируемых лапах |
| <b>D</b> Crane on embedded     | Gru su tronchetto         | Grue sur plinthe         | Kran auf Fundamentplatte     | Кран на фундаменте         |

**B** 1,7 m L = 4,5 m



EN 14439 - C25				EN 14439 - D25				FEM 1.001			
$\Delta H$ (m)	H (m)	Z** (t)	F1 (kN)	$\Delta H$ (m)	H (m)	Z** (t)	F1 (kN)	$\Delta H$ (m)	H (m)	Z** (t)	F1 (kN)
7	-	-	-	7	-	-	-	7	-	-	-
6	-	-	-	6	-	-	-	6	2,95 m	42,0	102,0
5	2,95 m	39,1	803	5	2,95 m	39,1	122,4	5	2,95 m	39,1	102,0
4	5,9 m	36,2	755	4	5,9 m	36,2	102,0	4	5,90 m	36,2	91,8
3	5,9 m	30,3	677	3	5,9 m	30,3	91,8	3	5,90 m	30,3	91,8
2	5,9 m	24,4	636	2	5,9 m	24,4	81,6	2	5,90 m	24,4	81,6
+1	5,9 m	18,5	603	+1	5,9 m	18,5	81,6	+1	5,90 m	18,5	71,4

**E** 1,7 m L = 4,5 m



EN 14439 - C25				EN 14439 - D25				FEM 1.001			
$\Delta H$ (m)	H (m)	Z** (t)	F1 (kN)	$\Delta H$ (m)	H (m)	Z** (t)	F1 (kN)	$\Delta H$ (m)	H (m)	Z** (t)	F1 (kN)
7	-	-	-	7	-	-	-	7	-	-	-
6	-	-	-	6	-	-	-	6	2,95 m	41,4	102,0
5	2,95 m	38,5	794	5	2,95 m	38,5	122,4	5	2,95 m	38,5	102,0
4	5,9 m	35,6	746	4	5,9 m	35,6	102,0	4	5,90 m	35,6	91,8
3	5,9 m	29,7	669	3	5,9 m	29,7	91,8	3	5,90 m	29,7	91,8
2	5,9 m	23,8	628	2	5,9 m	23,8	81,6	2	5,90 m	23,8	81,6
+1	5,9 m	17,9	620	+1	5,9 m	17,9	71,4	+1	5,90 m	17,9	71,4

**Z\*\***  **Comply with the specified ballast Z(t) / Attenersi alla zavorra indicata Z(t) / S'en tenir au lest indiqué Z(t) / Unbedingt die angegebenen Ballastwerte einhalten Z(t) / Соблюдать указанный балласт Z(t)**

**D**  1,7 m **STANDARD 1,7 CITY - 12t**

 EN 14439 - C25					 EN 14439 - D25					 FEM 1.001				
$\Delta H$ (m)	H (m)	F2 (kN)	F3 (kN)		$\Delta H$ (m)	H (m)	F2 (kN)	F3 (kN)		$\Delta H$ (m)	H (m)	F2 (kN)	F3 (kN)	
7	-	-	-	-	7	-	-	-	-	7	-	-	-	-
6	-	-	-	-	6	-	-	-	-	6	2,95 m	40,4	1202	865
5	2,95 m	37,5	1244	914	5	2,95 m	37,5	1244	914	5	2,95 m	37,5	1143	814
4	5,9 m	34,6	1178	862	4	5,9 m	34,6	1178	862	4	3,00 m	34,6	1085	764
3	5,9 m	28,7	1076	772	3	5,9 m	28,7	1076	772	3	3,00 m	28,7	988	695
2	5,9 m	22,8	990	747	2	5,9 m	22,8	990	747	2	5,90 m	22,8	922	680
+1	5,9 m	16,9	979	746	+1	5,9 m	16,9	979	746	+1	5,90 m	16,9	903	670

**B**  HC5S 2,1m L = 6,0 m **STANDARD 2,1 HC5S - 12t**

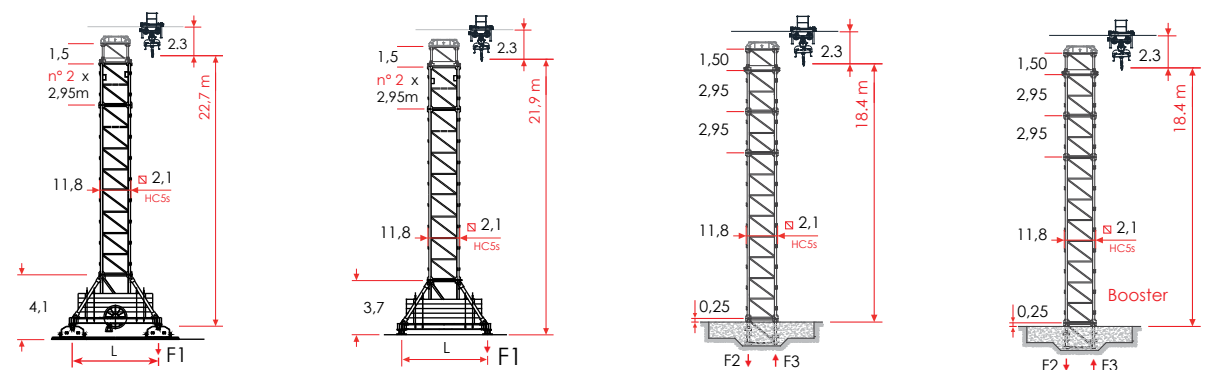

 EN 14439 - C25					 EN 14439 - D25					 FEM 1.001				
$\Delta H$ (m)	H* (m)	Z** (t)	F1 (kN)		$\Delta H$ (m)	H* (m)	Z** (t)	F1 (kN)		$\Delta H$ (m)	H* (m)	Z** (t)	F1 (kN)	
7	2,95 m	61,0	122,3	1283	7	-	-	-	-	7	2,95m	61,0	102,9	1161
6	5,9 m	58,1	115,8	1136	6	-	-	-	-	6	5,9 m	58,1	90,0	1115
5	5,9 m	52,2	96,5	879	5	5,9 m	52,2	122,3	1235	5	5,9 m	52,2	64,2	889
4	5,9 m	46,3	77,1	680	4	5,9 m	46,3	102,9	934	4	5,9 m	46,3	51,2	684
3	5,9 m	40,4	70,8	614	3	5,9 m	40,4	96,5	699	3	5,9 m	40,4	51,2	603
2	5,9 m	34,5	64,2	584	2	5,9 m	34,5	77,1	616	2	5,9 m	34,5	51,2	603
+1	5,9 m	28,6	51,2	535	+1	5,9 m	28,6	70,8	556	+1	5,9 m	28,6	51,2	580

**STANDARD 2,1 HC5S - 12t**



- B** Travelling base    Base traslante    Grue à traslation    Fahrbarer Kran    Кран передвижной
- E** Base on steel pads    Base con piedi regolabili    Grue sur pieds réglables    Kran auf verstellbaren Füßen    Кран на регулируемых лапах
- D** Crane on embedded    Gru su tronchetto    Grue sur plinthe    Kran auf Fundamentplatte    Кран на фундаменте

**E**  HC5S 2,1m L = 6,0 m

 EN 14439 - C25					 EN 14439 - D25					 FEM 1.001				
$\Delta H$ (m)	H* (m)	Z** (t)	F1 (kN)		$\Delta H$ (m)	H* (m)	Z** (t)	F1 (kN)		$\Delta H$ (m)	H* (m)	Z** (t)	F1 (kN)	
7	2,95 m	60,2	122,3	1242	7	-	-	-	-	7	2,95 m	60,2	102,9	1132
6	5,9 m	57,3	115,8	1098	6	-	-	-	-	6	5,9 m	57,3	90,0	1086
5	5,9 m	51,4	96,5	845	5	5,9 m	51,4	122,3	1189	5	5,9 m	51,4	64,2	862
4	5,9 m	45,5	77,1	666	4	5,9 m	45,5	102,9	894	4	5,9 m	45,5	51,2	660
3	5,9 m	39,6	70,8	601	3	5,9 m	39,6	96,5	672	3	5,9 m	39,6	51,2	590
2	5,9 m	33,7	64,2	571	2	5,9 m	33,7	77,1	603	2	5,9 m	33,7	51,2	550
+1	5,9 m	27,8	51,2	522	+1	5,9 m	27,8	70,8	544	+1	5,9 m	27,8	51,2	510

**Z\*\***  **Comply with the specified ballast Z(t) / Attenersi alla zavorra indicata Z(t) / S'en tenir au lest indiqué Z(t) / Unbedingt die angegebenen Ballastwerte einhalten Z(t) / Соблюдать указанный балласт Z(t)**



**D** STANDARD 2,1 HC5S - 12t

HC5S 2,1m					EN 14439 - C25					EN 14439 - D25					FEM 1.001					
$\Delta H$ (m)	H* (m)	F2 (kN)	F3 (kN)		$\Delta H$ (m)	H* (m)	F2 (kN)	F3 (kN)		$\Delta H$ (m)	H* (m)	F2 (kN)	F3 (kN)		$\Delta H$ (m)	H* (m)	F2 (kN)	F3 (kN)		
7	2,95 m	56,7	2100	1882	7	-	-	-	-	7	2,95 m	56,7	2056,2	1649						
6	5,9 m	53,8	1884	1674	6	-	-	-	-	6	5,9 m	53,8	1863,9	1465						
5	5,9 m	47,9	1490	1296	5	5,9 m	47,9	1975	1779	5	5,9 m	47,9	1485	1100						
4	5,9 m	42,0	1139	959	4	5,9 m	42,0	1524	1345	4	5,9 m	42,0	990	633						
3	5,9 m	36,1	1019	695	3	5,9 m	36,1	1128	963	3	5,9 m	36,1	905	564						
2	5,9 m	30,2	938	629	2	5,9 m	30,2	938	638	2	5,9 m	30,2	833	507						
+1	5,9 m	24,3	866	572	+1	5,9 m	24,3	866	572	+1	5,9 m	24,3	767	490						

**D** BOOSTER

HC5S 2,1m					EN 14439 - C25					EN 14439 - D25					FEM 1.001					
$\Delta H$ (m)	H* (m)	F2 (kN)	F3 (kN)		$\Delta H$ (m)	H* (m)	F2 (kN)	F3 (kN)		$\Delta H$ (m)	H* (m)	F2 (kN)	F3 (kN)		$\Delta H$ (m)	H* (m)	F2 (kN)	F3 (kN)		
10	-	-	-	-	10	-	-	-	-	10	-	-	-	-						
9	-	-	-	-	9	-	-	-	-	9	2,95 m	62,6	2056	1649						
8	2,95 m	62,6	2583	2345	8	-	-	-	-	8	2,95 m	59,7	1864	1465						
7	5,9 m	59,7	2335	2110	7	2,95 m	56,7	2784	2557											
					6	5,9 m	53,8	2494	2284											

**H\*** Climbing cage connection frame including / Telaio di raccordo a spinta incluso / Elément de telescopage compris /  
Включая соединительную раму подъемной клетки

**E** CITY - TP21/17S  
L = 6,0 m

EN 14439 - C25				
$\Delta H$ (m)	H (m)	Z** (t)	F1 (kN)	
CITY $\square$ 1,7 m	2,95 m	58,7	122,3	1016
CITY $\square$ 1,7 m	5,9 m			
CITY $\square$ 1,7 m	11,8 m			
CITY $\square$ 1,7 m	11,8 m			
TP 21/17s	5,9 m			
HC5S $\square$ 2,1 m	5,90 m			
HC5S $\square$ 2,1 m	11,8 m			
Base 6x6 m HC5S	3,75 m			

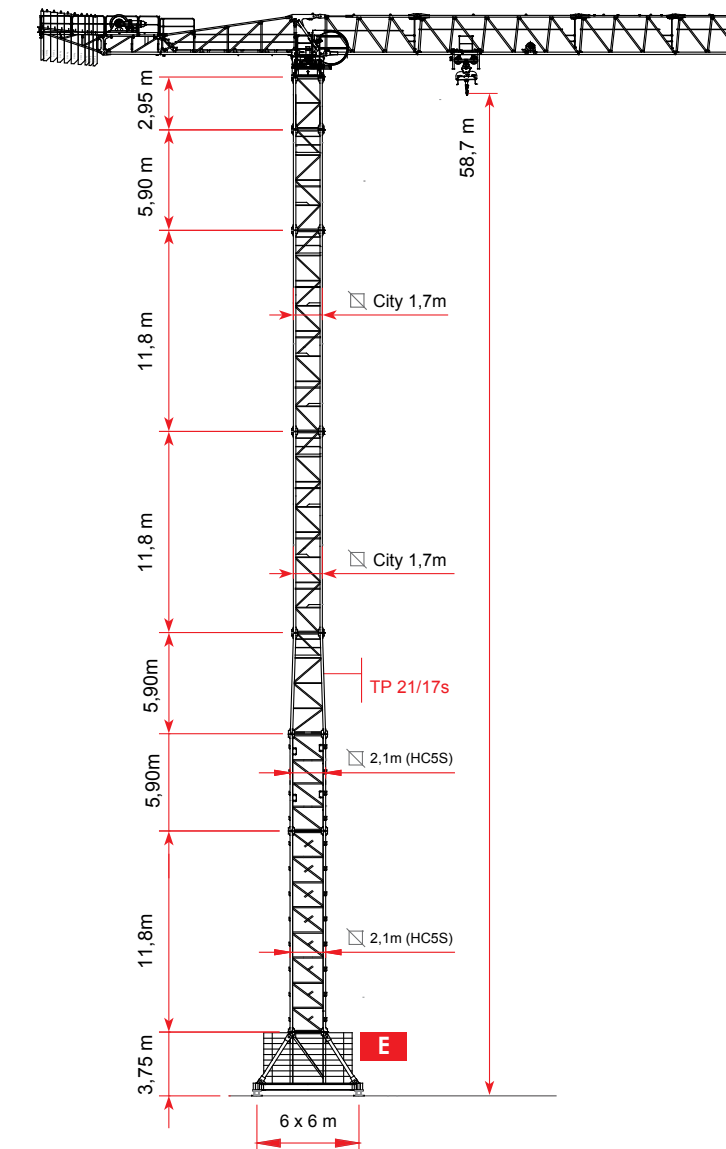



For different heights contact the technical department / Per altezze diverse contattare l'ufficio tecnico / Pour des hauteurs différentes contact le département technique / Für unterschiedliche Höhen Kontakt zum Technischen / Недопустимо увеличение высоты крана без согласования с технической службой производителя



Position of next anchor to increase height under hook / Posizione prossimo ancoraggio per aumento altezza sotto gancio / Position du prochain ancrage pour augmenter la hauteur sous crochet / Lage nächste Verankerung zur Erhöhung unter dem Haken / положение для следующего якоря большей высоты под крюком



Anchor position / Posizione d'ancoraggio / Position de ancrage / Verankerungsposition / позицию анкеровки



**FEM 1.001**

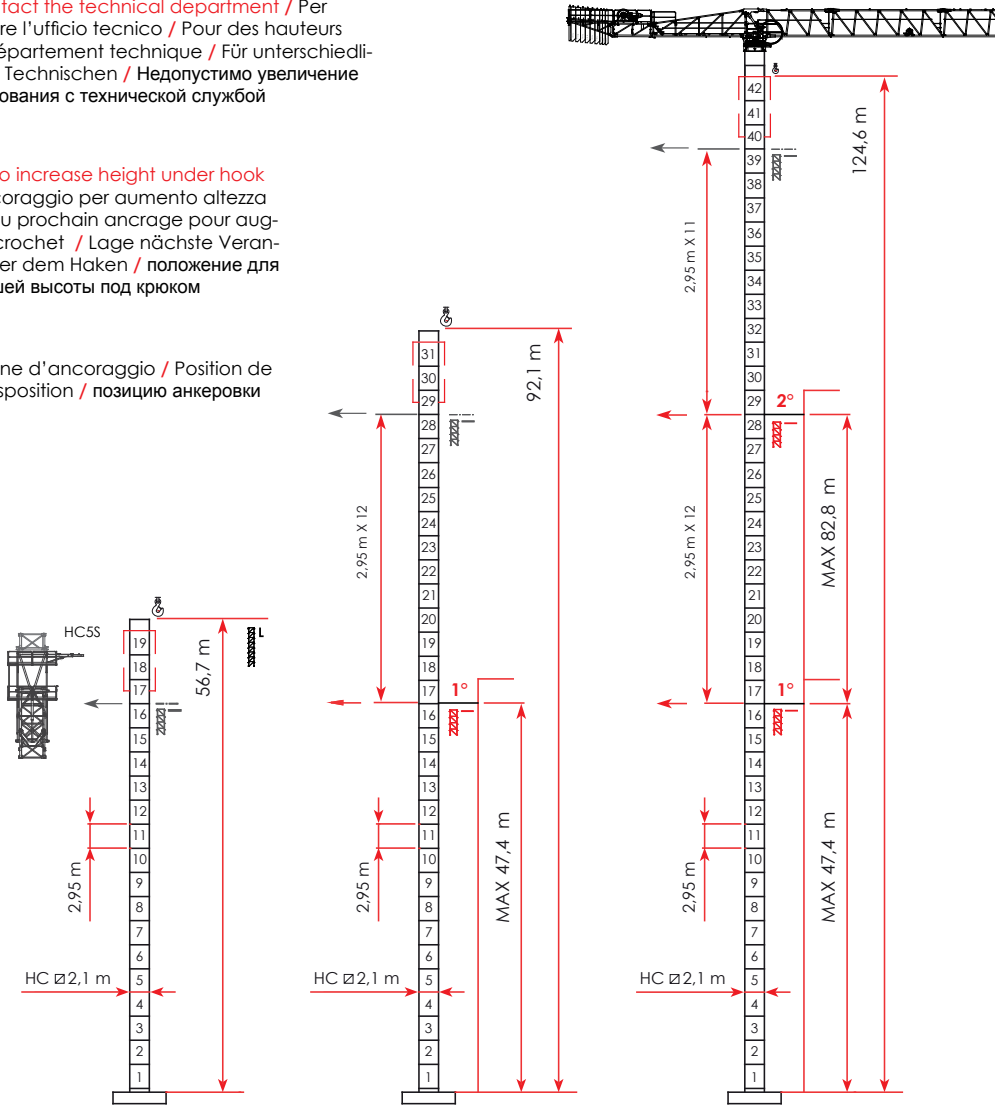

Climbing crane / Sopralzo idraulico / Télescopage sur dalles / Kletterkrane im Gebäude / Кран поднимающийся на плитах перекрытия



For different heights contact the technical department / Per altezze diverse contattare l'ufficio tecnico / Pour des hauteurs différentes contact le département technique / Für unterschiedliche Höhen Kontakt zum Technischen / Недопустимо увеличение высоты крана без согласования с технической службой производителя



Position of next anchor to increase height under hook / Posizione prossimo ancoraggio per aumento altezza sotto gancio / Position du prochain ancrage pour augmenter la hauteur sous crochet / Lage nächste Verankerung zur Erhöhung unter dem Haken / положение для следующего якоря большей высоты под крюком







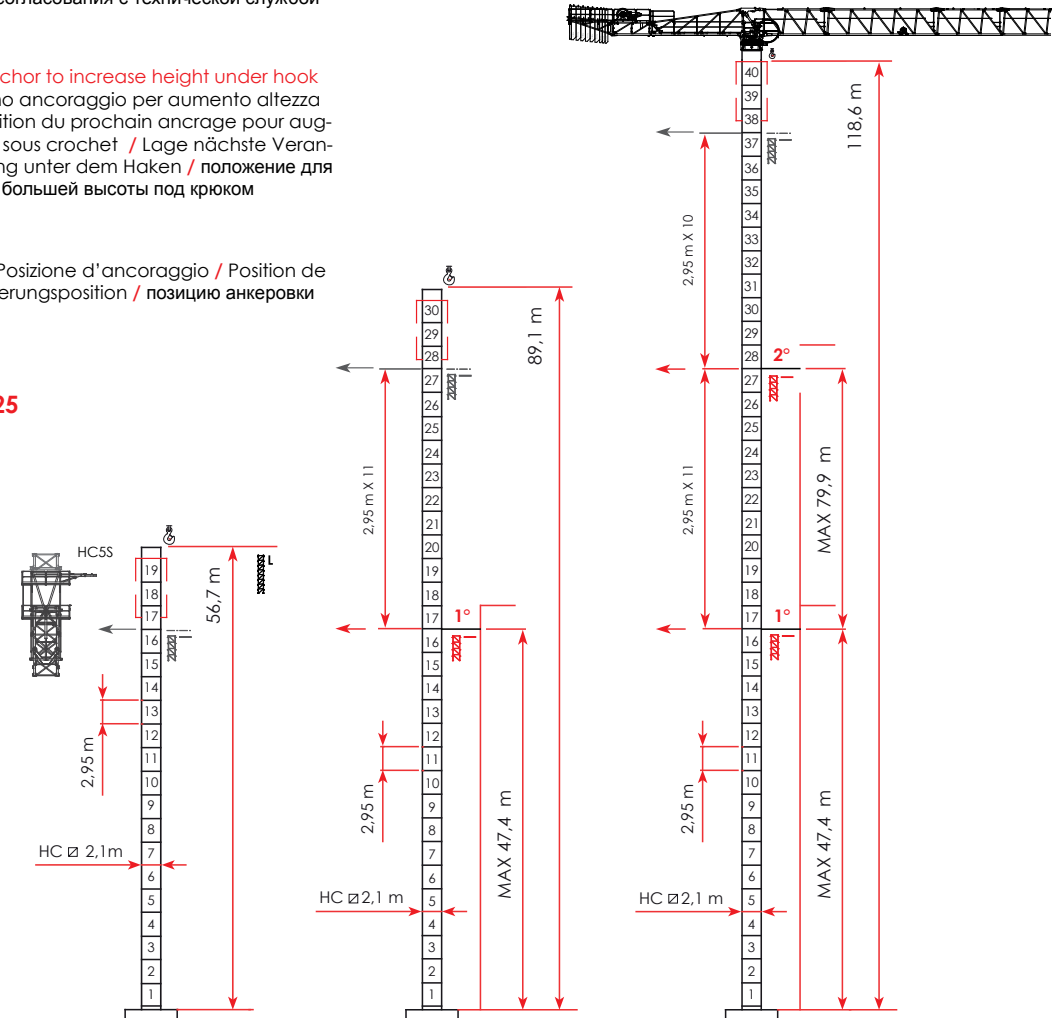

Anchor position / Posizione d'ancoraggio / Position de ancrage / Verankerungsposition / позицию анкеровки



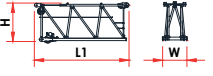
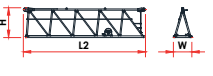
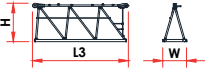
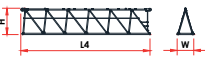
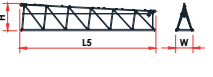

**EN 14439 - C25**

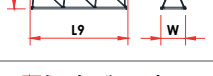

Climbing crane / Sopralzo idraulico / Télescopage sur dalles / Kletterkrane im Gebäude / Кран поднимающийся на плитах перекрытия

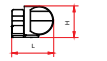
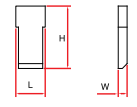
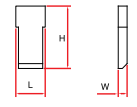
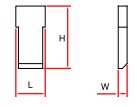
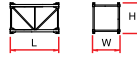
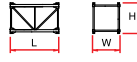
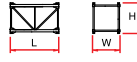
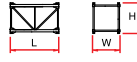
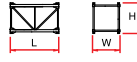
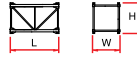
Description	Item	Pz	Drawing	Dimension ( m )			Weight ( kg )	
				n.	n°	L	W	H
<b>Jib element</b>	<b>1</b>	1		6,09	1,59	2,44	2 311	-
Elemento freccia		2		9,93	1,50	2,42	2 827	-
Elément de flèche		3		6,05	1,50	2,40	1 208	-
Auslegerement jib section		4		11,79	1,50	2,38	1 895	-
Секция стрелы		5		11,76	1,50	2,36	1 484	-
		6		4,06	1,50	1,79	431	-
		7		5,97	1,50	1,79	529	-
		8		5,96	1,50	1,78	415	-
		9		5,94	1,50	1,74	332	-
		10		4,01	1,50	1,73	232	-
		11		2,33	1,50	1,99	185	-

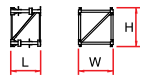
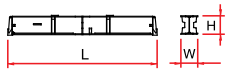
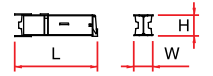
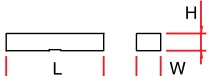
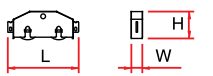
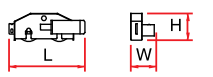
Description	Item	Pz	Drawing	Dimension ( m )			Weight ( kg )			
				n.	n°	L	W	H	Unit	Total
<b>Counterjib - tournable, hoisting winch, trolley jib, electrical box, terminal element / Controfreccia - girevole, argano sollevamento, quadro elettrico, carrello freccia, portablochi / Contreflèche tournante, treuil de levage, chariot de flèche, armoire électrique, élément terminal / Gegenausleger, Hubwinde, Laufkatze, Schaltschrank, Element für Gegengewichts Blöcke anführen / Консоль с поворотным кругом, лебедка, тележка, эл. ящик, противовесная консоль</b>	<b>2</b>	1		10,11	1,840	2,460	3 958	-		
		3,610	2,520	2,330	-	3 430				
		4,03	2,38	2,310	-	1 138				
		<b>City 1,7</b>	2,066	2,35	1,723	-	3 950			
		<b>HC5s</b>	2,332	2,35	1,738	-	4 350			
		2,305	1,933	2,070	-	-				
		<b>Access balcony, cabin / Ballatoio cabina, cabina / Porte cabine / Kabine Podest, Kabine / Платформа кабины, кабина</b>	3	1		3,640	5,020	2,450	-	5 686
		<b>Counterweight block / Blocchi di contrappeso / Contre - poids / Gegengewichts Blöcke / Блоки противовеса</b>	<b>4</b>	2		<b>A234</b>	1,18	0,41	2,910	3160
		4			<b>B234</b>	1,18	0,24	2,910	1870	
		4			<b>C234</b>	1,18	0,16	2,910	1255	
		<b>Tower element / Elementi di torre / Elément de mature / Turmstück / Башенные секции</b>	<b>5</b>	-		<b>CITY 1,7</b>	2,95	1,900	1,700	1400
-				<b>HC5s</b>	2,95	2,300	2,300	1900	-	
-				<b>CITY 1,7</b>	5,90	1,900	1,700	2295	-	
-				<b>HC5s</b>	5,90	2,300	2,300	3450	-	
-				<b>CITY 1,7</b>	11,8	1,900	1,700	4175	-	
-		<b>HC5s</b>	11,8	2,300	2,300	5920	-			

Description	Item n.	Pz n°	Drawing	Dimension ( m )			Weight ( kg )	
				l	w	h	Unit	Total
<b>Expendable foundation element /</b> Tronchetto di fondazione / Elément a sceller / Fundamentanker / Анкер	8	1		<b>CITY 1,7</b> 1,465	1,98	1,98	830	-
				<b>HC5s</b> 1,82	2,40	2,40	1398	-
<b>Base main beam /</b> Trave principale crociera di base / Poutre de chassis de base / Haupt-träger für Kreuzbase / Главная балка крестовины основания	9	1		<b>4,5 x 4,5 m - 1,7m CITY</b>			-	2595
				6,530	0,780	0,960	-	-
<b>Half base beam /</b> Semitrave di base / Semipoutre de chassis de base / Halb-träger für Kreuzbase / Полубалка основания	10	2		<b>4,5 x 4,5 m - 1,7m CITY</b>			1 235	2470
				3,212	0,680	0,974	-	-
<b>Concrete pad /</b> Blocco di appoggio / Sabot en béton / Beton Fuß / Опорный блок	11	4		<b>B5</b>			5 520	-
				3,600	0,900	0,750	-	-
<b>Driving bogie /</b> Bilancino di traslazione folle / Boggie fou / Schaukel Bewegung - Neutralstellung / Не приводной балансир	12	2		1,320	0,230	0,540	600	-
				-	-	-	-	-
<b>Driven bogie /</b> Bilancino di traslazione motorizzato / Boggie motorisée / Schaukel Bewegung - Betriebene / Приводной балансир	13	2		1,430	0,500	0,540	765	-
				-	-	-	-	-
<b>Base ballast block /</b> Blocco di zavorra / Lest de base / Grundballast / блок балласта	14	-		<b>GB5F</b>			5 100	-
				4,300	1,200	0,430	-	-



5 x 13,60 m

MRT234 HC \_Jib 70 m • HUH 0,0 m

Top part / Parte rotante / Partie tournante / Drehender Kranteil / Поворотная часть



4 x 40 High cube

1 x 40 Box

1 x 40 Open Top

Included counter weight and cabin / Cabina e contrappesi inclusi / Cabine et contrepoids inclus / Kabine und Gegengewichts Blöcke – inbegriffen / Противовес включен - кабина



As part of our mission to deliver superior models to market, a key production pillar at Raimondi Cranes is prioritizing crane operator comfort and ease-of-use in all of our products







The Raimondi MRT294 topless tower crane 16 tonne is one of Raimondi's most popular models, specifically with general contractors and developers employing precast systems





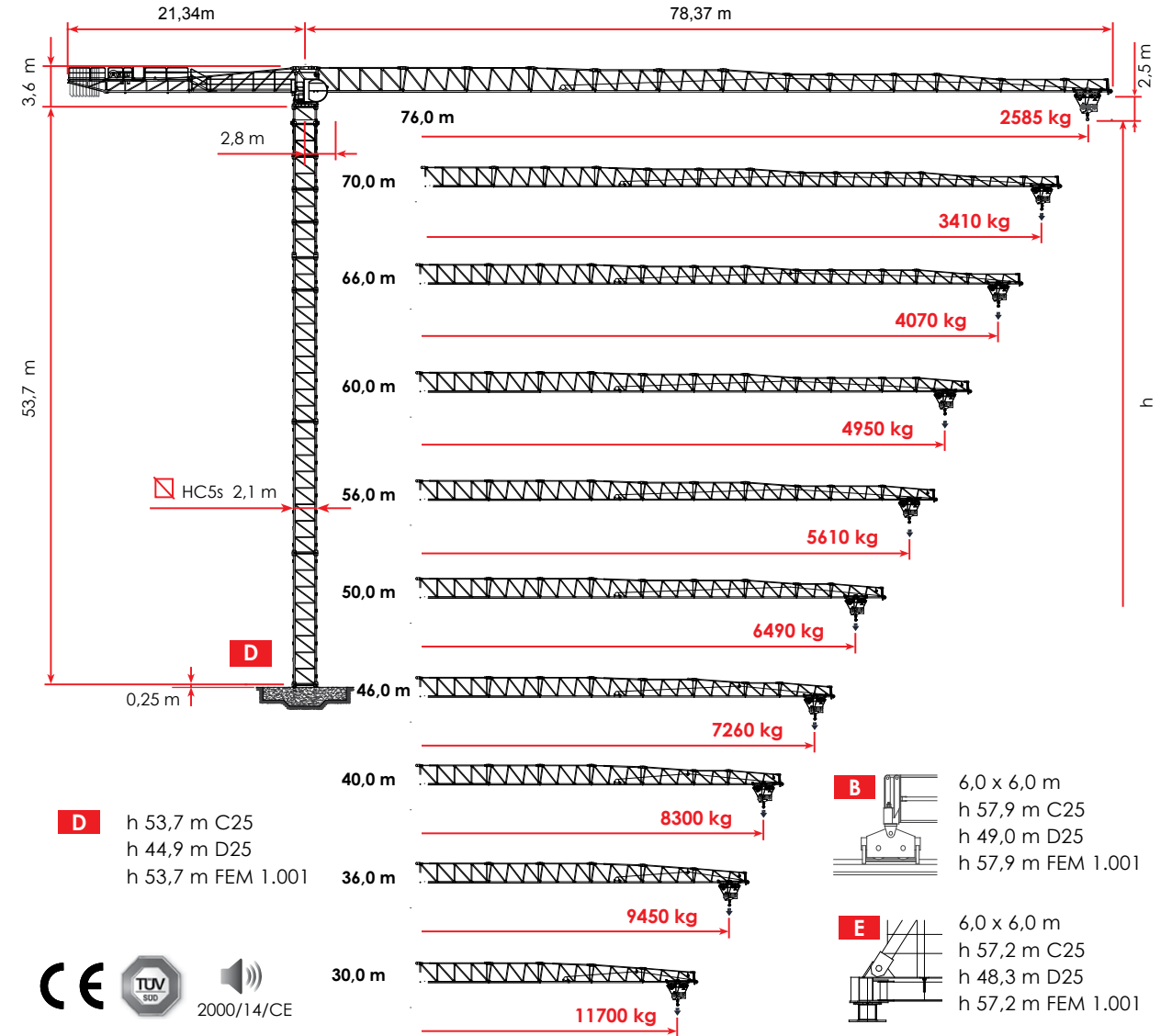











# RAIMONDI<sup>®</sup> MRT294

SINCE 1863







   2000/14/CE  
A4 EN 14439 C25 D25 - FEM 1.001



IT	EN	F	DE	RU
 Altezza sotto gancio	Height under hook	Hauteur sous crochet	Höhe unter dem Haken	Высота под крюком
 Contrappesi	Counter weight jib ballast	Lest de contre-flèche	Gegenauslegerballast	Противовесы
 Freccia	Jib	Flèche	Kranarm	стрела крана
 Carico massimo	Max load	Charge maximale	Maximale Belastung	максимальная нагрузка
 Curva di carico Ultralift	Load diagrams with ultralift control	Courbes de charges Ultralift	Lastkurven Ultralift	Кривой Груз Ultralift
 Altezza libera	Free Standing	Hauteur libre	Freistehend	Свободностоящая высота
 Azionamenti	Mechanisms	Mécanismes	Antriebe	Приводы
 Velocità	Speed	Vitesse	Geschwindigkeit	скорость
<b>5*</b> 5 marce con velocità proporzionale al carico	5 step with speed proportional to the load	5 rapports avec une vitesse proportionnelle à la charge	5 Gang Geschwindigkeit proportional zum Last	Автоматический выбор скорости механизма подъема в зависимости от величины груза
 Tiro a 2 funi	Two - rope pull	Tir à deux câbles	Zug an zwei Seilen	Двукратная запасовка тросов
 Tiro a 4 funi	Four - rope pull	Tir à quatre câbles	Zug an vier Seilen	Четырехкратная запасовка тросов
 Totale metri fune tamburo	Total meters rope drum			Запас троса на барабане в метрах
 Totale metri fune tamburo	Total meters rope drum	Total des mètres de corde du tambour	Total Meter Seil Trommel	Запас троса на барабане в метрах
 Diametro fune	Rope diameter	Diamètre du câble	Seildurchmesser	Диаметр троса
 Carrello	Trolley	Chariot	Katzfahren	Тележка
 Traslazione	Travelling	Translation	Kranfahren	Перемещение крана



			MAX 	46 m	50 m	56 m	60 m	66 m	70 m	76 m
kg	m	14,0 t								
23169	<b>76</b>	18,0	5038	4571	3997	3680	3278	3048	<b>2750</b>	
21438	<b>70</b>	20,4	5847	5313	4659	4296	3837	<b>3575</b>		
21438	<b>66</b>	22,4	6753	5841	5129	4735	<b>4235</b>			
19707	<b>60</b>	24,2	6920	6299	5537	<b>5115</b>				
17976	<b>56</b>	24,7	6786	6443	<b>5665</b>					
16245	<b>50</b>	25,3	6993	<b>6655</b>						







 400 V ± 5% 50 Hz

 II

 IV

 2000 / 14 / CE

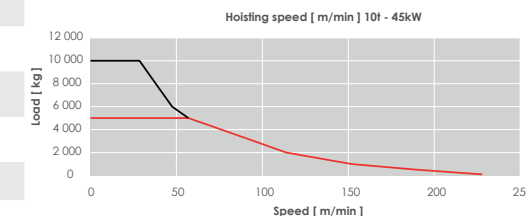

**14,0 t 75 hp 55 kW** STEP

					
		m/min	kg	m/min	kg
 500 m	1	8	7000	4	14000
 125 kVA	2	24	7000	12	14000
 Ø 16 mm	3	40	7000	20	14000
	4	64	3600	32	7200
	5	80	2500	40	5000
	<b>5*</b>	104	0 - 1000	52	0 - 2000



kVA Power required / Potenza richiesta / Puissance requise / Erforderliche Leistung / Потребляемая мощность

(\*\*) The number of motors depends on the length of the jib / Il numero di motori dipende dalla lunghezza del braccio

 0,26/ 0,48/ 0,7 min<sup>-1</sup> • 4 (\*\*)\* x 4 kW /  13,0/ 37,0/ 59,0/ 74,0 <sup>(\*)</sup> m/min • 6,6 kW /  19 m/min • 4 x 4 kW

400 V ± 5% 50 Hz



2000 / 14 / CE

**14,0 t 100 hp 73,5 kW**

	STEP	II		IV	
		m/min	kg	m/min	kg
700 m	1	8	7000	4	14000
155 kVA	2	30	7000	15	14000
Ø 16 mm	3	52	7000	26	14000
	4	92	3750	46	7500
	5	136	2500	68	5000

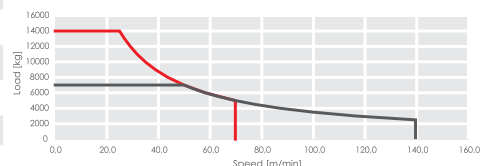

**16,0 t 75 hp 55 kW**

	STEP	II		IV	
		m/min	kg	m/min	kg
500 m	1	8	8000	4	16000
125 kVA	2	24	8000	12	16000
Ø 16 mm	3	40	8000	20	16000
	4	64	4000	32	8000
	5	80	2500	40	5000
	5*	104	0 - 1200	52	0 - 2400

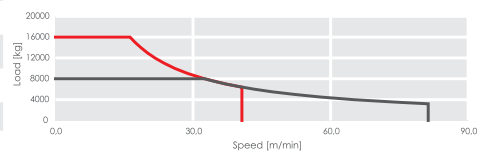

**16,0 t 100 hp 73,5 kW**

	STEP	II		IV	
		m/min	kg	m/min	kg
700 m	1	8	8000	4	16000
155 kVA	2	30	8000	15	16000
Ø 16 mm	3	52	8000	26	16000
	4	92	4000	46	8000
	5	136	2500	68	5000

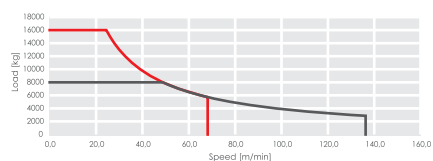

kVA Power required / Potenza richiesta / Puissance requise / Erforderliche Leistung / Потребляемая мощность

\* Speed automatically controlled by a current sensor / Velocità regolata automaticamente da sensore di corrente / Vitesse réglée automatiquement par capteur de courant / Automatisch durch Stromsensor geregelte geschwindigkeit / СКОРОСТЬ АВТОМАТИЧЕСКИ КОНТРОЛИРУЕТСЯ ДАТЧИКОМ НАПРЯЖЕНИЯ

(\*\*) The number of motors depends on the length of the jib / Il numero di motori dipende dalla lunghezza del braccio

0,26 / 0,48 / 0,7 min<sup>-1</sup> • 4 (\*\*\*) x 4 kW / 13,0 / 37,0 / 59,0 / 74,0 (\*\*) m/min • 6,6 kW / 19 m/min • 4 x 4 kW



JIB	30	36	40	46	50	56	60	66	70	76
2,8 ▶	25.9	25.9	25.8	25.6	25.3	24.7	24.2	22.4	20.4	18.0
15	14000	14000	14000	14000	14000	14000	14000	14000	14000	14000
16	14000	14000	14000	14000	14000	14000	14000	14000	14000	14000
18	14000	14000	14000	14000	14000	14000	14000	14000	14000	14000
20	14000	14000	14000	14000	14000	14000	14000	14000	14000	12430
22	14000	14000	14000	14000	14000	14000	14000	14000	14000	12863
24	14000	14000	14000	14000	14000	14000	14000	12919	11635	10051
26	13979	13967	13898	13744	13561	13186	12931	11786	10606	9148
28	12851	12840	12776	12634	12464	12117	11881	10822	9729	8380
<b>30</b>	<b>11880</b>	11869	11810	11677	11519	11196	10977	9991	8974	7718
32		11024	10969	10845	10697	10395	10190	9267	8316	7142
34		10282	10230	10114	9975	9691	9498	8632	7739	6910
<b>36</b>		<b>9625</b>	9576	9466	9336	9068	8886	8070	7228	6675
38			8993	8889	8766	8513	8340	7568	7050	6277
<b>40</b>			<b>8470</b>	8371	8254	8014	7851	7119	6853	5919
42				7904	7793	7565	7409	6916	6484	5597
44				7481	7374	7157	7009	6753	6151	5304
<b>46</b>				<b>7095</b>	6993	6786	6920	6422	5847	5038
48					6968	6747	6597	6119	5568	4794
<b>50</b>					<b>6655</b>	6443	6299	5841	5313	4571
52					6163	6025	5585	5078	4364	
54						5905	5772	5349	4860	4174
<b>56</b>						<b>5665</b>	5537	5129	4659	3997
58							5319	4925	4471	3833
<b>60</b>							<b>5115</b>	4735	4296	3680
62								4557	4133	3537
64								4391	3980	3403
<b>66</b>								<b>4235</b>	3837	3278
68									3702	3159
<b>70</b>									<b>3575</b>	3048
72										2943
74										- 250 kg
<b>76</b>										<b>2750</b>

MRT294 - 14,0t / 7,0t

**ULTRALIFT** If the crane is not equipped with Ultralift control, all intermediate loads are decreased by 10% / Senza il sistema Ultralift tutte le portate intermedie diminuiscono il carico del 10% / Les charges intermediaires sont diminuées de 10% si la grue n'est pas équipé d'un controle Ultralift. / Mit dem ULTRALIFT-System erhöhen alle Zwischenbelastbarkeiten die Last um 10% / Без ULTRALIFT промежуточный вес уменьшается на 10%.

JIB	30	36	40	46	50	56	60	66	70	76
2,8 ▶	22.0	22.7	22.6	22.4	22.0	21.3	20.9	19.3	17.5	15.4
15	16000	16000	16000	16000	16000	16000	16000	16000	16000	16000
16	16000	16000	16000	16000	16000	16000	16000	16000	16000	15308
18	16000	16000	16000	16000	16000	16000	16000	16000	15455	13355
20	16000	16000	16000	16000	16000	16000	16000	15408	13693	11815
22	16000	16000	16000	16000	15974	15451	15112	13819	12269	10571
24	15077	15764	14764	14764	14475	13997	13688	12508	11094	9544
26	13770	13721	13632	13482	13217	12778	12493	11408	10107	8662
28	12658	12613	12530	12392	12146	11739	11476	10472	9268	7948
<b>30</b>	<b>11700</b>	11658	11581	11452	11223	10845	10599	9665	8544	7774
32		10826	10755	10634	10420	10066	9837	8963	7915	7227
34	IV	10096	10029	9916	9715	9382	9167	8346	7880	6746
<b>36</b>		<b>9450</b>	9387	9280	9090	8777	8574	7800	7390	6321
38			8814	8713	8534	8237	8045	7671	6953	5942
<b>40</b>			<b>8300</b>	8204	8034	7753	7842	7242	6560	5601
42				7745	7892	7762	7426	6854	6206	5294
44				7630	7492	7368	7048	6503	5886	5016
<b>46</b>				<b>7260</b>	7128	7010	6704	6184	5593	4763
48					6796	6682	6389	5891	5236	4531
<b>50</b>					<b>6490</b>	6381	6100	5622	5080	4318
52						6104	5834	5375	4854	4122
54						5848	5588	5146	4645	3940
<b>56</b>						<b>5610</b>	5360	4934	4451	3772
58							5148	4737	4271	3616
<b>60</b>							<b>4950</b>	4553	4103	3470
62							4382	3946	3334	
64							4221	3800	3207	
<b>66</b>							<b>4070</b>	3662	3087	
68								3532	2975	
<b>70</b>								<b>3410</b>	2869	
72									2769	
74									2674	
<b>76</b>									<b>2585</b>	

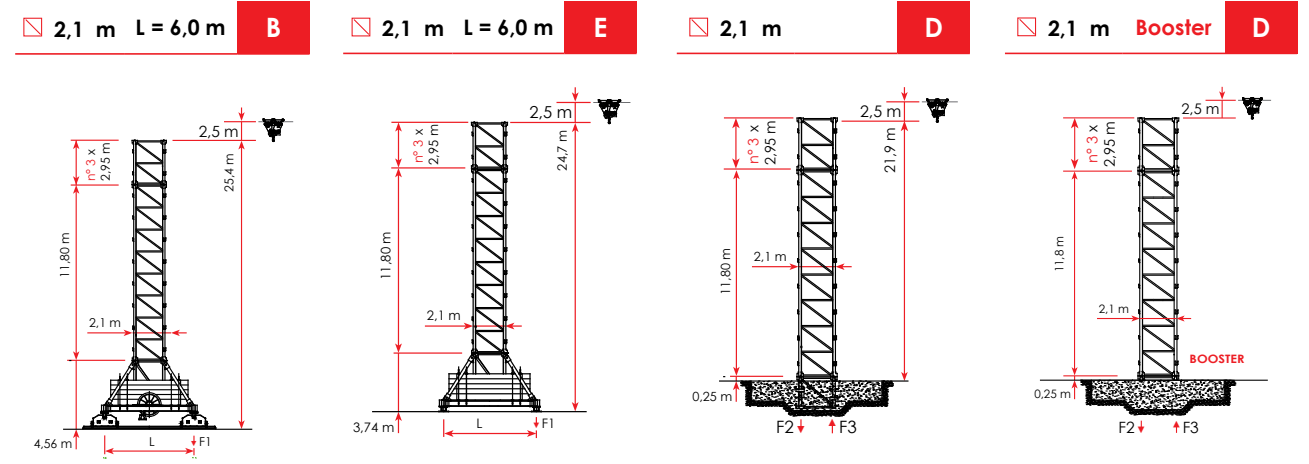

MRT294 - 16,0t / 8,0t

**ULTRALIFT** If the crane is not equipped with Ultralift control, all intermediate loads are decreased by 10% / Senza il sistema Ultralift tutte le portate intermedie diminuiscono il carico del 10% / Les charges intermediaires sont diminuées de 10% si la grue n'est pas équipé d'un controle Ultralift. / Mit dem ULTRALIFT-System erhöhen alle Zwischenbelastbarkeiten die Last um 10% / Без ULTRALIFT промежуточный вес уменьшается на 10%.



B				E				D						
HC5S 2,1m				L = 6,0 m										
EN 14439 - C25				EN 14439 - D25				FEM 1.001						
$\Delta H$ (m)	H* (m)	Z** (t)	F1 (kN)	$\Delta H$ (m)	H* (m)	Z** (t)	F1 (kN)	$\Delta H$ (m)	H* (m)	Z** (t)	F1 (kN)			
11	2,95 m	57,9	109,4	1163	-	-	-	-	11	2,95 m	57,9	83,5	1061	
10	2,95 m	55,0	96,5	1029	-	-	-	-	10	2,95 m	55,0	83,5	972	
9	2,95 m	52,0	90,0	903	-	-	-	-	9	2,95 m	52,0	83,5	885	
8	2,95 m	49,1	83,5	848	8	2,95 m	49,0	109,4	1109	8	2,95 m	49,1	83,5	875
7	2,95 m	46,1	83,5	828	7	2,95 m	46,1	96,5	966	7	2,95 m	46,1	77,1	870
6	2,95 m	43,2	83,5	808	6	2,95 m	43,1	90,0	841	6	2,95 m	43,2	77,1	750
5	2,95 m	40,2	83,5	773	5	2,95 m	40,2	83,5	788	5	2,95 m	40,2	70,6	811
4	2,95 m	37,3	83,5	755	4	2,95 m	37,2	83,5	770	4	2,95 m	37,3	70,6	777
3	2,95 m	34,3	83,5	589	3	2,95 m	34,3	83,5	583	3	2,95 m	34,3	70,6	755
2	2,95 m	31,4	77,1	568	2	2,95 m	31,3	83,5	567	2	2,95 m	31,4	70,6	726
+1	2,95 m	28,4	77,1	512	+1	2,95 m	28,4	77,1	567	+1	2,95 m	28,4	70,6	718



**E**  **HC5S 2,1m** **L = 6,0 m** **STANDARD 2,1 HC5S - 14t**

 <b>EN 14439 - C25</b>					 <b>EN 14439 - D25</b>					 <b>FEM 1.001</b>				
$\Delta H$ (m)	H* (m)	Z** (t)	F1 (kN)		$\Delta H$ (m)	H* (m)	Z** (t)	F1 (kN)		$\Delta H$ (m)	H* (m)	Z** (t)	F1 (kN)	
11	2,95 m	57,2	109,4	1124	-	-	-	-	-	11	2,95 m	57,2	83,5	1036
10	2,95 m	54,3	96,5	991	-	-	-	-	-	10	2,95 m	54,3	83,5	948
9	2,95 m	51,3	90,0	873	-	-	-	-	-	9	2,95 m	51,3	83,5	860
8	2,95 m	48,4	83,5	835	8	2,95 m	48,3	109,4	1065	8	2,95 m	48,4	83,5	852
7	2,95 m	45,4	83,5	814	7	2,95 m	45,4	96,5	924	7	2,95 m	45,4	77,1	845
6	2,95 m	42,5	83,5	794	6	2,95 m	42,4	90,0	812	6	2,95 m	42,5	77,1	820
5	2,95 m	39,5	83,5	759	5	2,95 m	39,5	83,5	775	5	2,95 m	39,5	70,6	786
4	2,95 m	36,6	83,5	741	4	2,95 m	36,5	83,5	757	4	2,95 m	36,6	70,6	765
3	2,95 m	33,6	83,5	582	3	2,95 m	33,6	83,5	582	3	2,95 m	33,6	70,6	730
2	2,95 m	30,7	77,1	540	2	2,95 m	30,6	83,5	566	2	2,95 m	30,7	70,6	712
+1	2,95 m	27,7	77,1	498	+1	2,95 m	27,7	77,1	566	+1	2,95 m	27,7	70,6	693

**Z\*\***  **Comply with the specified ballast Z(t) / Attenersi alla zavorra indicata Z(t) / S'en tenir au lest indiqué Z(t) / Unbedingt die angegebenen Ballastwerte einhalten Z(t) / Соблюдать указанный балласт Z(t)**



<b>B</b>	Travelling base	Base traslante	Grue à traslation	Fahrbarer Kran	Кран передвижной
<b>E</b>	Base on steel pads	Base con piedi regolabili	Grue sur pieds réglables	Kran auf verstellbaren Füßen	Кран на регулируемых лапах
<b>D</b>	Crane on embedded	Gru su tronchetto	Grue sur plinthe	Kran auf Fundamentplatte	Кран на фундаменте

**D**  **HC5S 2,1m** **STANDARD 2,1 HC5S - 14t**

 <b>EN 14439 - C25</b>					 <b>EN 14439 - D25</b>					 <b>FEM 1.001</b>				
$\Delta H$ (m)	H* (m)	F2 (kN)	F3 (kN)		$\Delta H$ (m)	H* (m)	F2 (kN)	F3 (kN)		$\Delta H$ (m)	H* (m)	F2 (kN)	F3 (kN)	
11	2,95 m	53,7	1689	1271	-	-	-	-	-	11	2,95 m	53,7	1533	1108
10	2,95 m	50,8	1485	1075	-	-	-	-	-	10	2,95 m	50,8	1401	951
9	2,95 m	47,8	1294	892	-	-	-	-	-	9	2,95 m	47,8	1222	735
8	2,95 m	44,9	1117	722	8	2,95 m	44,9	1552	1158	8	2,95 m	44,9	1175	702
7	2,95 m	41,9	952	565	7	2,95 m	42,0	1336	950	7	2,95 m	41,9	1138	668
6	2,95 m	39,0	798	481	6	2,95 m	39,0	1136	757	6	2,95 m	39,0	1102	641
5	2,95 m	36,0	765	484	5	2,95 m	36,1	950	580	5	2,95 m	36,0	1071	617
4	2,95 m	33,1	721	475	4	2,95 m	33,1	779	438	4	2,95 m	33,1	1042	564
3	2,95 m	30,1	684	420	3	2,95 m	30,2	754	488	3	2,95 m	30,1	995	558
2	2,95 m	27,2	612	385	2	2,95 m	27,2	748	491	2	2,95 m	27,2	952	512
+1	2,95 m	24,2	521	380	+1	2,95 m	24,2	738	484	+1	2,95 m	24,2	915	494

**H\***  **Climbing cage connection frame including / Telaio di raccordo a spinta incluso / Elément de telescopage compris / DE .. / Включая соединительную раму подъемной клетки**

**D**  **HC5S 2,1m** **BOOSTER**

 <b>EN 14439 - C25</b>					 <b>EN 14439 - D25</b>					 <b>FEM 1.001</b>				
$\Delta H$ (m)	H* (m)	F2 (kN)	F3 (kN)		$\Delta H$ (m)	H* (m)	F2 (kN)	F3 (kN)		$\Delta H$ (m)	H* (m)	F2 (kN)	F3 (kN)	
+15	2,95 m	62,5	2881	2415	+11	2,95 m	53,7	2781	2350	+15	2,95 m	65,5	2352	1802





For different heights contact the technical department / Per altezze diverse contattare l'ufficio tecnico / Pour des hauteurs différentes contact le département technique / Für unterschiedliche Höhen Kontakt zum Technischen / Недопустимо увеличение высоты крана без согласования с технической службой производителя



Position of next anchor to increase height under hook / Posizione prossimo ancoraggio per aumento altezza sotto gancio / Position du prochain ancrage pour augmenter la hauteur sous crochet / Lage nächste Verankerung zur Erhöhung unter dem Haken / положение для следующего якоря большей высоты под крюком



Anchor position / Posizione d'ancoraggio / Position de ancrage / Verankerungsposition / позицию анкеровки







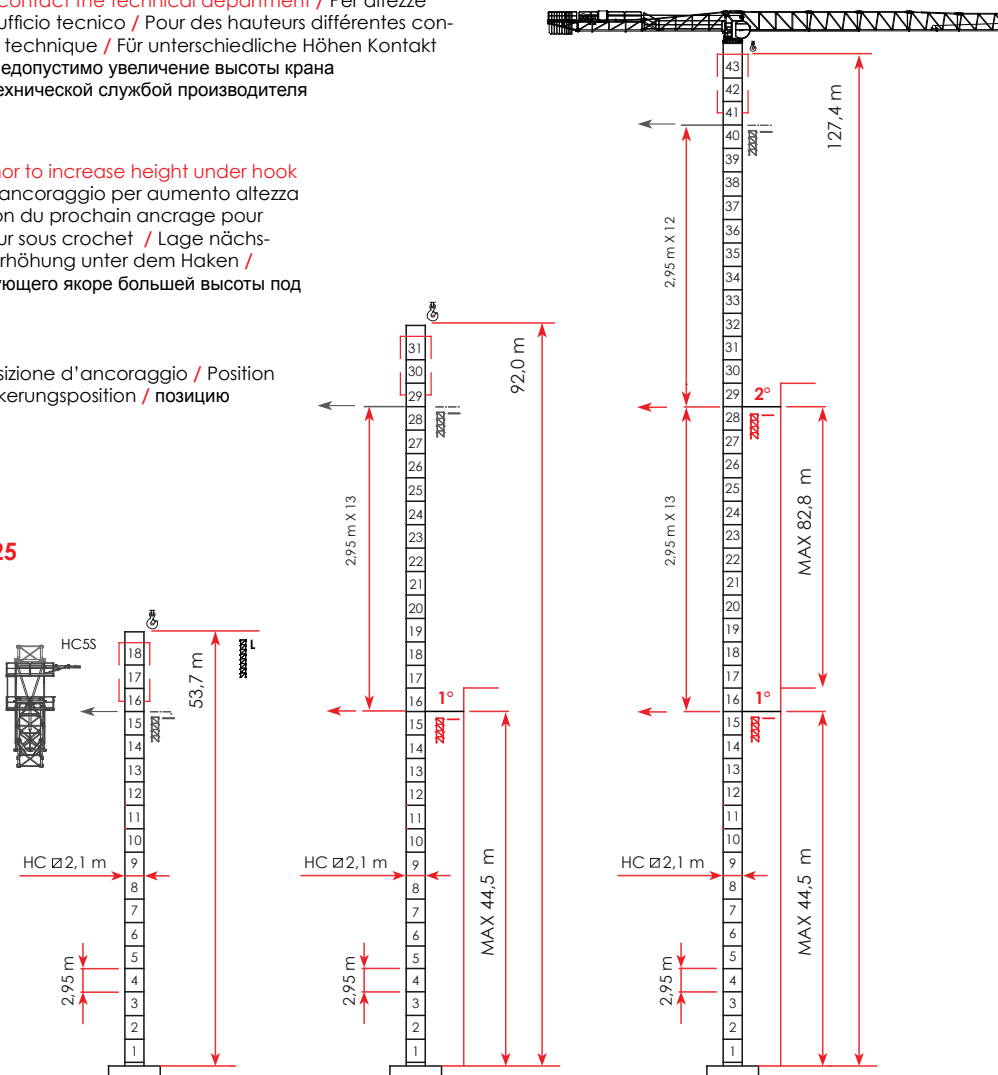

**FEM 1.001**

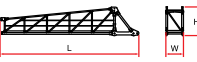
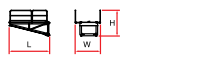
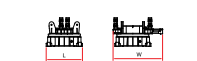
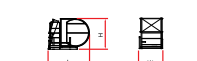

**EN 14439 - C25**

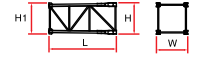
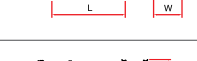

Climbing crane / Sopralzo idraulico / Télescopage sur dalles / Kletterkrane im Gebäude / Кран поднимающийся на плитах перекрытия

Description	Item n.	Pz n°	Drawing	Dimension ( m )			Weight ( kg )	
				l	w	h	Unit	Total
<b>Jib element</b>	<b>1</b>	1		8,390	1,500	2,375	3365	-
Elemento freccia								
Élément de flèche								
Auslegerelement jib section								
Секция стрелы								
	2			6,109	1,500	2,301	1940	-
	3			6,084	1,500	2,290	1664	-
	4			6,135	1,500	2,290	1566	-
	5			6,159	1,500	2,090	1300	-
	6			6,109	1,500	2,090	1040	-
	7			6,104	1,500	2,090	996	-
	8			4,204	1,500	1,680	632	-
	9			6,105	1,500	1,680	744	-
	10			4,124	1,500	1,660	426	-
	11			6,035	1,500	1,660	652	-
	12			5,965	1,500	1,210	492	-
	13			4,066	1,500	1,210	306	-
	14			5,920	1,500	1,210	398	-
				0,900	1,530	1,385	98	-

Description	Item n.	Pz n°	Drawing	Dimension ( m )			Weight ( kg )		
				l	w	h	Unit	Total	
Counterjib - tournable, hoisting winch, trolley jib, electrical box, terminal element / Controfreccia - girevole, argano sollevamento, quadro elettrico, carrello freccia, portablocchi / Contreflèche tournante, treuil de levage, chariot de flèche, armoire électrique, élément terminal / Gegenausleger, Hubwinde, Laufkatze, Schaltschrank, Element für Gegengewichts Blöcke anführen / Консоль с поворотным кругом, лебедка, тележка, эл. ящик, противовесная консоль	2	1		7,745	2,290	2,395	4700	-	
				11,850	1,500	2,440	5400	-	
				3,610	2,255	2,300	900	-	
				2,300	3,150	1,900	6800	-	
Access balcony, cabin / Ballatoio cabina, cabina / Porte cabine / Kabine Podest, Kabine / Платформа кабины, кабина	3	6		3,600	2,200	2,240	1450	-	
				A 294	0,295	1,490	2,570	2419	14514
Counterweight block / Blocchi di contrappeso / Contre - poids / Gegengewichts Blöcke / Блоки противовеса	4	5		B 294	0,210	1,490	2,570	1731	8655
				HC55	11,80	2,300	2,300	5920	-
Tower element / Elementi di torre / Elément de mature / Turmstück / Башенные секции	5	-		HC55	5,90	2,300	2,300	3450	-
				HC55	2,95	2,300	2,300	1900	-
	6	-		HC6	5,000	2,325	H 2,320 H1 2,300	3000	-
				HC6	6,000	2,325	2,320	5555	-
Base element / Elemento di base / Mat de base / Элемент основания	7	-		3,000	2,400	2,400	1950	-	
Climbing Cage / Gabbia di montaggio / Semipoutre de chassis de base / Montagekäfig	8	-		8,530	3,100	2,300	7670	-	

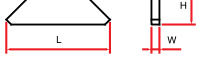
Description	Item n.	Pz n°	Drawing	Dimension ( m )			Weight ( kg )				
				l	w	h	Unit	Total			
Expendable foundation element / Tronchetto di fondazione / Elément a sceller / Fundamentanker / Анкер	9	1		1,820	2,400	2,400	1370	-			
Fixing angles / Gambe di fondazione / Pieds de scellement / ножки основания	10	4		1,820	0,470	0,470	280	1120			
Obliquial legs / Puntoni di base / Jambes de force / Стойки основания	11	4		3,770	0,230	0,260	340	1360			
Base main beam / Trave principale crociera di base / Poutre de chassis de base / Haupt-träger für Kreuzbase / Главная балка крестовины основания	12	1		<b>6,0 x 6,0 m</b>			8,900	0,720	0,760	1650	-
					4,350	0,600	0,760	750	1500		
Half base beam / Semitrave di base / Semipoutre de chassis de base / Halb-träger für Kreuzbase / Полубалка основания	13	2		1,750	0,705	0,790	1500	-			
Driven bogie / Bilancino di traslazione motorizzato / Boggie motoriseè / Schaukel Bewegung - Betriebene / Приводной балансир	14	4		4,200	0,320	1,400	3,230	-			
Base ballast block / Blocco di zavorra / Lest de base / Grundballast / блок балласта	15	-		3G	4,200	0,320	1,400	3,230	-		
				3H	5,200	0,400	1,400	6240	-		



6 x 13,60 m

MRT294 HC \_Jib 76 m • HUH 0,0 m

Top part / Parte rotante / Partie tournante / Drehender Kranteil / Поворотная часть



4 x 40 High cube

Included counter weight and cabin / Cabina e contrappesi inclusi / Cabine et contrepoids inclus / Kabine und Gegengewichts Blöcke – inbegriffen / Противовес включен - кабина

1 x 20 Box

3 x 40 Open Top



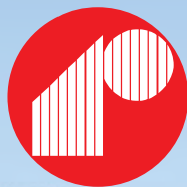

**RAIMONDI**®  
SINCE 1863

**LUFFING CRANES**

The Raimondi LR273 luffing jib crane is simultaneously fitted for two different types of tower sections, GR6L and GR5H, allowing fleet rental companies to maximize client fit for purpose



The Raimondi LR60 luffing jib crane  
in Equatorial Guinea at work onsite



**RAIMONDI**® LR60  
SINCE 1863

LR60

5t 

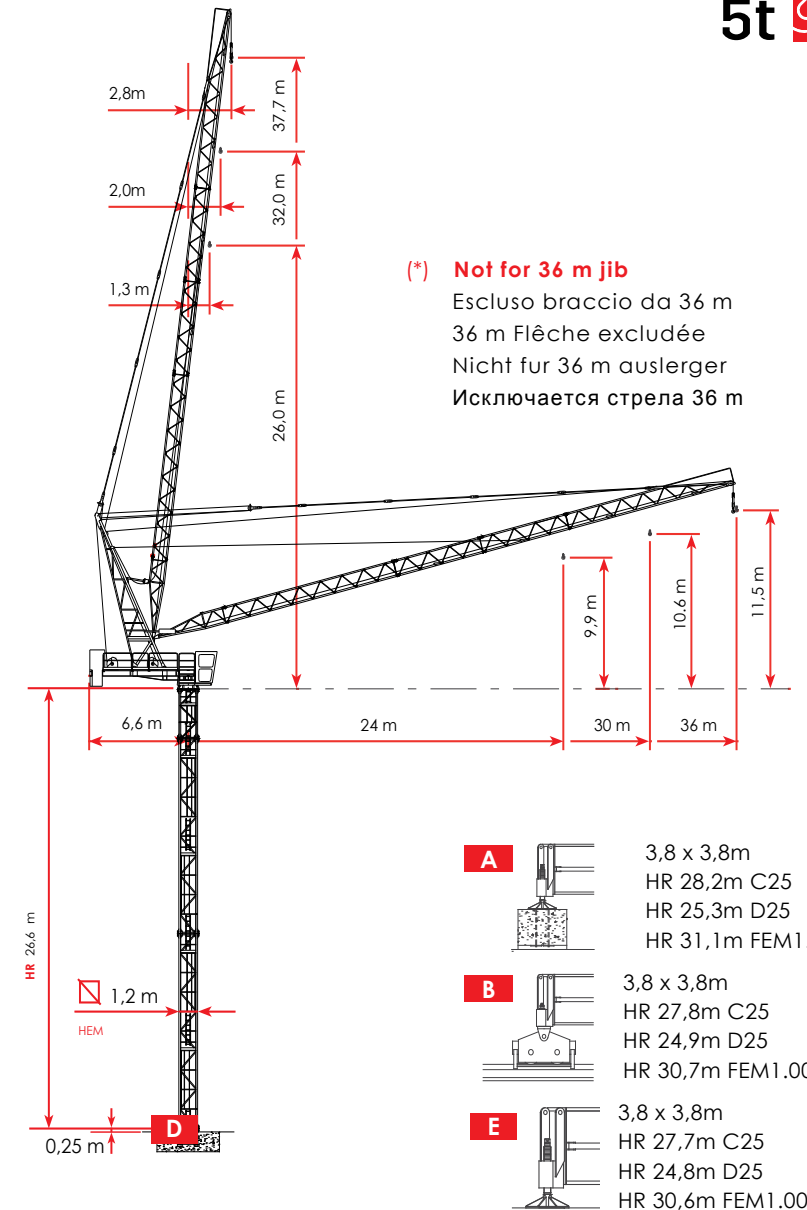















**HR** Main bearing level  
Altezza ralla  
Hauteur couronne  
Drehsattel Höhe  
Высота упорного подшипника

**D** HR 27,0m C25  
HR 24,1m D25  
HR 29,9m  
FEM1.001





A4 EN 14439 C25 D25 - FEM  
1.001





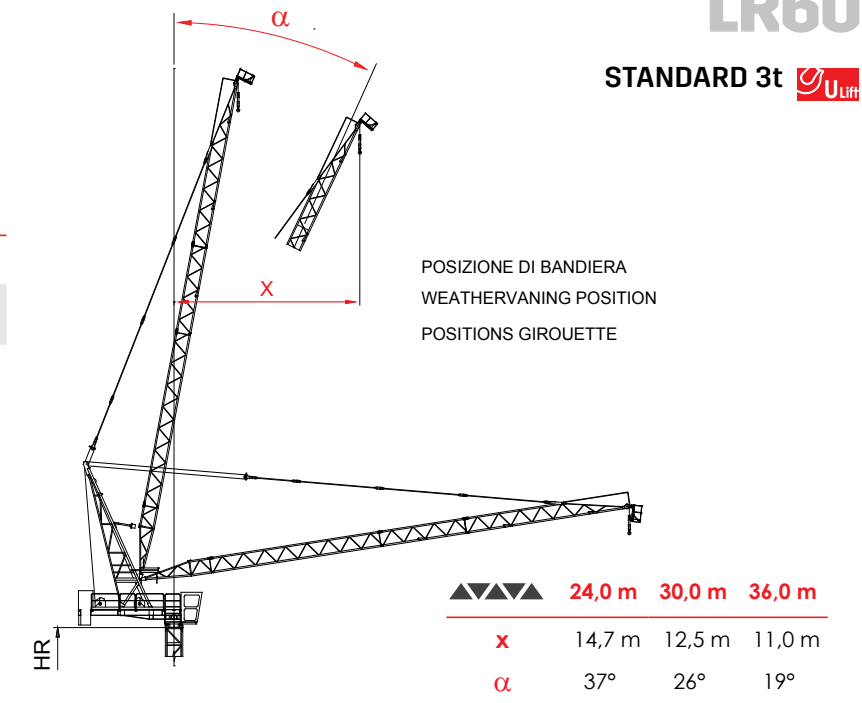

IT	EN	F	DE	RU
 Altezza sotto gancio	Height under hook	Hauteur sous crochet	Höhe unter dem Haken	Высота под крюком
 Contrappesi	Counter weight jib ballast	Lest de contre-flèche	Gegenauslegerballast	Противовесы
 Freccia	Jib	Flèche	Kranarm	стрела крана
 Carico massimo	Max load	Charge maximale	Maximale Belastung	максимальная нагрузка
 Curva di carico Ultralift	Load diagrams with ultralift control	Courbes de charges Ultralift	Lastkurven Ultralift	Кривой Груз Ultralift
 Altezza libera	Free Standing	Hauteur libre	Freistehend	Свободностоящая высота
 Azionamenti	Mechanisms	Mécanismes	Antriebe	Приводы
 Velocità	Speed	Vitesse	Geschwindigkeit	скорость
<b>5*</b> 5 marce con velocità proporzionale al carico	5 step with speed proportional to the load	5 rapports avec une vitesse proportionnelle à la charge	5 Gang Geschwindigkeit proportional zum Last	Автоматический выбор скорости механизма подъема в зависимости от величины груза
 Tiro a 2 funi	Two - rope pull	Tir à deux câbles	Zug an zwei Seilen	Двукратная запасовка тросов
 Tiro a 4 funi	Four - rope pull	Tir à quatre câbles	Zug an vier Seilen	Четырехкратная запасовка тросов
 Totale metri fune tamburo	Total meters rope drum	Total des mètres de corde du tambour	Total Meter Seil Trommel	Запас троса на барабане в метрах
 Diametro fune	Rope diameter	Diamètre du câble	Seildurchmesser	Диаметр троса
 Rotazione	Slewing	Orientation	Schwenken	Поворот
 Braccio impennabile	Luffing jib	Flèche rélevable	Arm mit erhöht	Стрела крана подъемный
 Traslazione	Travelling	Translation	Kranfahren	Перемещение крана

kg	m	3,0 t	m
5042	<b>36</b>	23	2828 1999 <b>1430</b>
4680	<b>30</b>	24	3000 <b>2200</b>
4276	<b>24</b>	30	<b>3000</b>





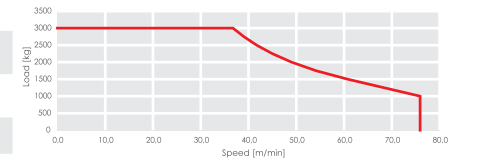

 400 V ± 5% 50 Hz    2000 / 14 / CE

3,0 t 30 hp 22 kW	STEP	 m/min	 kg
 240 m	1	8	3000
 70 kVA	2	22	3000
 Ø 12 mm	3	36	3000
	4	56	1500
	5	70	1000
	<b>5*</b>	84	0 - 400



kVA Power required / Potenza richiesta / Puissance requise / Erforderliche Leistung / Потребляемая мощность

 0 / 0,76 r.p.m. • 3,2 kW /  14,5° / 85° 1,73 m/min • 18,4 kW /  14 m/min • 2 x 2,9 kW

 400 V ± 5% 50 Hz

 2000 / 14 / CE

**5,0 t 30 hp 22 kW**

STEP





m/min

kg



m/min

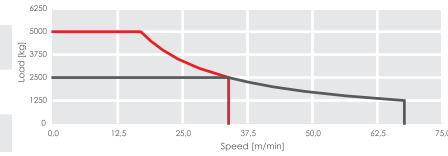

kg



 345 m	1	8	2500	4	5000
 70 kVA	2	24	2500	12	5000
 Ø 11 mm	3	38	2500	19	5000
	4	60	1250	30	2500
	5	75	850	37,5	1700
	<b>5*</b>	90	0 - 400	45	0 - 80



kVA Power required / Potenza richiesta / Puissance requise / Erforderliche Leistung / Потребляемая мощность



 0 / 0,76 r.p.m. ▪ 3,0 kW /  14,5° / 85° 1,73m/min ▪ 18,4 kW /  14 m/min ▪ 2 x 2,9 kW

	JIB	24	30	36
	0,0 ▶			
	14	3000	3000	3000
	<b>15</b>	3000	3000	3000
	16	3000	3000	3000
	<b>17</b>	3000	3000	3000
	18	3000	3000	3000
	<b>19</b>	3000	3000	3000
	20	3000	3000	3000
	21	3000	3000	3000
	<b>22</b>	3000	3000	3000
	23	3000	3000	3000
<b>LR60 - 3,0t</b>	<b>24</b>	<b>3000</b>	3000	2828
	25		2882	2664
	<b>26</b>		2725	2512
	27		2581	2371
	<b>28</b>		2446	2239
	29		2318	2115
	<b>30</b>		<b>2200</b>	1999
	<b>31</b>			1890
	<b>32</b>			1787
	<b>33</b>			1690
	<b>34</b>			1599
	<b>35</b>			1512
	<b>36</b>			<b>1430</b>

	JIB	24	30	36
	0,0 ▶			
	14	5000	5000	5000
	<b>15</b>	5000	5000	5000
	16	5000	5000	4772
	<b>17</b>	4891	4704	4441
	18	4587	4397	4143
	<b>19</b>	4310	4120	3873
	20	4060	3868	3626
	21	3830	3637	3401
	<b>22</b>	3619	3425	3194
	23	3424	3229	3004
<b>LR60 - 2,5t / 5,0t</b>	<b>24</b>	<b>3245</b>	3049	2828
	25		2882	2664
	<b>26</b>		2725	2512
	27		2581	2371
	<b>28</b>		2446	2239
	29		2318	2115
	<b>30</b>		<b>2200</b>	1999
	<b>31</b>			1890
	<b>32</b>			1787
	<b>33</b>			1690
	<b>34</b>			1599
	<b>35</b>			1512
	<b>36</b>			<b>1430</b>

**ULTRALIFT** If the crane is not equipped with Ultralift control, all intermediate loads are decreased by 10% / Senza il sistema Ultralift tutte le portate intermedie diminuiscono il carico del 10% / Les charges intermediaires sont diminuées de 10% si la grue n'est pas équipé d'un controle Ultralift. / Mit dem ULTRALIFT-System erhöhen alle Zwischenbelastbarkeiten die Last um 10% / Без ULTRALIFT промежуточный вес уменьшается на 10%.

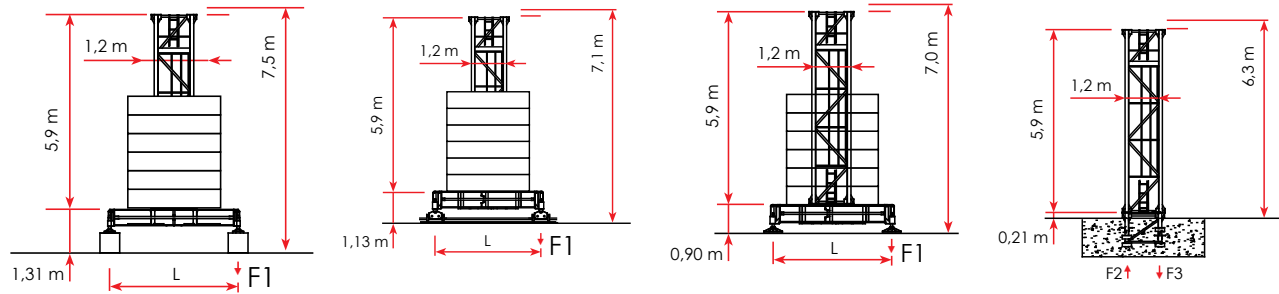
A 1,2 m L = 3,8 m   
 B 1,2 m L = 3,8 m   
 E 1,2 m L = 3,8 m   
 D 1,2 m



- |          |                       |                           |                          |                              |                            |
|----------|-----------------------|---------------------------|--------------------------|------------------------------|----------------------------|
| <b>A</b> | Base on concrete pads | Base su zatteroni         | Grue sur blocs d'appui   | Kran auf Stützblöcken        | Кран на опорных блоках     |
| <b>B</b> | Travelling base       | Base traslante            | Grue à traslation        | Fahrbarer Kran               | Кран передвижной           |
| <b>E</b> | Base on steel pads    | Base con piedi regolabili | Grue sur pieds réglables | Kran auf verstellbaren Füßen | Кран на регулируемых лапах |
| <b>D</b> | Crane on embedded     | Gru su tronchetto         | Grue sur plinthe         | Kran auf Fundamentplatte     | Кран на фундаменте         |

**A** 1,2 m - L = 3,8 m **CITY**

	EN 14439 - C25				EN 14439 - D25				FEM 1.001					
	ΔH (m)	HR (m)	Z** (t)	F1 (kN)	ΔH (m)	HR (m)	Z** (t)	F1 (kN)	ΔH (m)	HR (m)	Z** (t)	F1 (kN)		
6	-	-	-	-	6	-	-	-	6	-	-	-		
5	-	-	-	-	5	-	-	-	5	-	-	-		
4	3,0 m	28,2	89,1	600	4	3,0 m	25,3	89,1	575	4	5,9 m	31,1	59,4	542
3	5,9 m	25,2	89,1	534	3	3,0 m	22,3	89,1	617	3	5,9 m	25,2	49,5	469
2	5,9 m	19,3	69,3	402	2	5,9 m	19,3	79,2	504	2	5,9 m	19,3	39,6	314
+1	5,9 m	13,4	59,4	335	+1	5,9 m	13,4	59,4	364	+1	5,9 m	13,4	29,7	250

**B** 1,2 m - L = 3,8 m **HEM** **STANDARD 1,2 CITY 5t**

	EN 14439 - C25				EN 14439 - D25				FEM 1.001					
	ΔH (m)	HR (m)	Z** (t)	F1 (kN)	ΔH (m)	HR (m)	Z** (t)	F1 (kN)	ΔH (m)	HR (m)	Z** (t)	F1 (kN)		
6	-	-	-	-	6	-	-	-	6	-	-	-		
5	-	-	-	-	5	-	-	-	5	-	-	-		
4	3,0 m	27,8	89,2	596	4	3,0 m	24,9	89,2	564	4	5,9 m	30,7	59,4	545
3	5,9 m	24,8	89,2	534	3	3,0 m	21,9	89,2	611	3	5,9 m	24,8	49,5	470
2	5,9 m	18,9	69,3	402	2	5,9 m	18,9	79,2	503	2	5,9 m	18,9	39,6	315
+1	5,9 m	13,0	59,4	337	+1	5,9 m	13,0	59,4	364	+1	5,9 m	13,0	29,7	250

**E** 1,2 m - L = 3,8 m **CITY**

	EN 14439 - C25				EN 14439 - D25				FEM 1.001					
	ΔH (m)	HR (m)	Z** (t)	F1 (kN)	ΔH (m)	HR (m)	Z** (t)	F1 (kN)	ΔH (m)	HR (m)	Z** (t)	F1 (kN)		
6	-	-	-	-	6	-	-	-	6	-	-	-		
5	-	-	-	-	5	-	-	-	5	-	-	-		
4	3,0 m	27,7	89,2	587	4	3,0 m	24,8	89,2	556	4	5,9 m	30,6	59,4	541
3	5,9 m	24,7	89,2	527	3	3,0 m	21,8	89,2	600	3	5,9 m	24,7	49,5	468
2	5,9 m	18,8	69,3	395	2	5,9 m	18,8	79,2	496	2	5,9 m	18,8	39,6	313
+1	5,9 m	12,9	59,4	333	+1	5,9 m	12,9	59,4	357	+1	5,9 m	12,9	29,7	250

**Z\*\***  **Comply with the specified ballast Z(t) /** Attenersi alla zavorra indicata Z(t) / S'en tenir au lest indiqué Z(t) / Unbedingt die angegebenen Ballastwerte einhalten Z(t) / Соблюдать указанный балласт Z(t)

D 1,2 m CITY					STANDARD 1,2 CITY 5t									
EN 14439 - C25					EN 14439 - D25					FEM 1.001				
ΔH (m)	HR (m)	F2 (kN)	F3 (kN)		ΔH (m)	HR (m)	F2 (kN)	F3 (kN)		ΔH (m)	HR (m)	F2 (kN)	F3 (kN)	
6	-	-	-	-	6	-	-	-	-	6	-	-	-	-
5	-	-	-	-	5	-	-	-	-	5	-	-	-	-
4	3,0 m	27,0	1197	1082	4	3,0 m	24,1	1073	967	4	5,9 m	29,9	1049	943
3	5,9 m	24,0	859	750	3	3,0 m	21,1	1125	1019	3	5,9 m	24,0	883	781
2	5,9 m	18,1	593	492	2	5,9 m	18,1	943	841	2	5,9 m	18,1	637	542
+1	5,9 m	12,2	497	378	+1	5,9 m	12,2	630	536	+1	5,9 m	12,2	552	441

**HR**  Main bearing level / Altezza ralla / Hauteur couronne / Drehsattel Höhe /  
 ВЫСОТА УПОРНОГО ПОДШИПНИКА

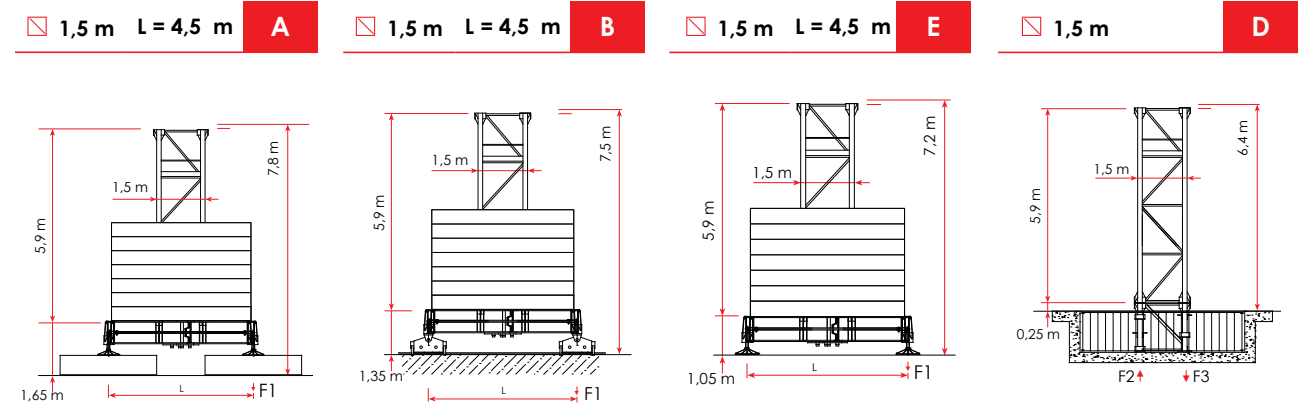



















- |          |                       |                           |                          |                              |                            |
|----------|-----------------------|---------------------------|--------------------------|------------------------------|----------------------------|
| <b>A</b> | Base on concrete pads | Base su zatteroni         | Grue sur blocs d'appui   | Kran auf Stützblöcken        | Кран на опорных блоках     |
| <b>B</b> | Travelling base       | Base traslante            | Grue à traslation        | Fahrbarer Kran               | Кран передвижной           |
| <b>E</b> | Base on steel pads    | Base con piedi regolabili | Grue sur pieds réglables | Kran auf verstellbaren Füßen | Кран на регулируемых лапах |
| <b>D</b> | Crane on embedded     | Gru su tronchetto         | Grue sur plinthe         | Kran auf Fundamentplatte     | Кран на фундаменте         |



















A 1,5 m - L = 4,5 m					EN 14439 - C25					EN 14439 - D25					FEM 1.001								
ΔH (m)	HR (m)	Z** (t)	F1 (kN)		ΔH (m)	HR (m)	Z** (t)	F1 (kN)		ΔH (m)	HR (m)	Z** (t)	F1 (kN)		ΔH (m)	HR (m)	Z** (t)	F1 (kN)					
6	-	-	-	-	6	-	-	-	-	6	-	-	-	-	6	-	-	-	-				
5	-	-	-	-	5	-	-	-	-	5	5,9 m	41,3	80,6	752	5	5,9 m	41,3	80,6	752				
4	1,2 m	5,9 m	35,4	104,9	629	4	1,2 m	3,0 m	32,5	114,8	731	4	1,2 m	5,9 m	35,4	74,7	714	4	1,2 m	5,9 m	35,4	74,7	714
3	1,2 m	5,9 m	29,5	85,0	541	3	1,2 m	5,9 m	29,5	104,9	732	3	1,2 m	5,9 m	29,5	57,0	550	3	1,2 m	5,9 m	29,5	57,0	550
2	1,2 m	5,9 m	23,6	65,2	415	2	1,2 m	5,9 m	23,6	75,1	546	2	1,2 m	5,9 m	23,6	45,2	405	2	1,2 m	5,9 m	23,6	45,2	405
+1	1,2 m	5,9 m	17,7	65,2	399	+1	1,2 m	5,9 m	17,7	65,2	412	+1	1,2 m	5,9 m	17,7	33,4	294	+1	1,2 m	5,9 m	17,7	33,4	294
+1 TP 12/15	4,0 m					+1 TP 12/15	4,0 m					+1 TP 12/15	4,0 m										



**B**  1,5 m - L = 4,5 m STANDARD 1,5 CITY / TP 1215 - 5t



















 EN 14439 - C25					 EN 14439 - D25					 FEM 1.001				
$\Delta H$ (m)	HR (m)	Z** (t)	F1 (kN)		$\Delta H$ (m)	HR (m)	Z** (t)	F1 (kN)		$\Delta H$ (m)	HR (m)	Z** (t)	F1 (kN)	
6	-	-	-	-	6	-	-	-	-	6	-	-	-	-
5	-	-	-	-	5	-	-	-	-	5	5,9 m	41,0	82,6	743
 4 1,2 m	5,9 m	35,1	99,1	612	 4 1,2 m	3,0 m	32,2	109,0	719	 4 1,2 m	5,9 m	35,1	76,7	706
 3 1,2 m	5,9 m	29,2	79,2	524	 3 1,2 m	5,9 m	29,2	109,0	723	 3 1,2 m	5,9 m	29,2	59,0	542
 2 1,2 m	5,9 m	23,3	59,4	399	 2 1,2 m	5,9 m	23,3	79,2	529	 2 1,2 m	5,9 m	23,3	47,2	398
 +1 1,2 m	5,9 m	17,4	59,4	380	 +1 1,2 m	5,9 m	17,4	59,4	396	 +1 1,2 m	5,9 m	17,4	35,4	303
 +1 TP 12/15	4,0 m				 +1 TP 12/15	4,0 m				 +1 TP 12/15	4,0 m			

**E**  1,5 m - L = 4,5 m

 EN 14439 - C25					 EN 14439 - D25					 FEM 1.001				
$\Delta H$ (m)	HR (m)	Z** (t)	F1 (kN)		$\Delta H$ (m)	HR (m)	Z** (t)	F1 (kN)		$\Delta H$ (m)	HR (m)	Z** (t)	F1 (kN)	
6	-	-	-	-	6	-	-	-	-	6	-	-	-	-
5	-	-	-	-	5	-	-	-	-	5	5,9 m	40,7	82,6	735
 4 1,2 m	5,9 m	34,8	99,1	607	 4 1,2 m	3,0 m	31,9	109,0	714	 4 1,2 m	5,9 m	34,8	76,7	697
 3 1,2 m	5,9 m	28,9	79,2	519	 3 1,2 m	5,9 m	28,9	109,0	716	 3 1,2 m	5,9 m	28,9	59,0	534
 2 1,2 m	5,9 m	23,0	59,4	394	 2 1,2 m	5,9 m	23,0	79,2	523	 2 1,2 m	5,9 m	23,0	47,2	391
 +1 1,2 m	5,9 m	17,1	59,4	374	 +1 1,2 m	5,9 m	17,1	59,4	391	 +1 1,2 m	5,9 m	17,1	35,4	299
 +1 TP 12/15	4,0 m				 +1 TP 12/15	4,0 m				 +1 TP 12/15	4,0 m			

**Z\*\***  Comply with the specified ballast Z(t) / Attenersi alla zavorra indicata Z(t) / S'en tenir au lest indiqué Z(t) / Unbedingt die angegebenen Ballastwerte einhalten Z(t) / Соблюдать указанный балласт Z(t)

**D**  1,5 m STANDARD 1,5 CITY / TP 1215 - 5t

 EN 14439 - C25					 EN 14439 - D25					 FEM 1.001				
$\Delta H$ (m)	HR (m)	F2 (kN)	F3 (kN)		$\Delta H$ (m)	HR (m)	F2 (kN)	F3 (kN)		$\Delta H$ (m)	HR (m)	F2 (kN)	F3 (kN)	
6	-	-	-	-	6	-	-	-	-	6	-	-	-	-
5	-	-	-	-	5	-	-	-	-	5	5,9 m	39,9	1406	1256
 4 1,2 m	5,9 m	34,0	1242	1117	 4 1,2 m	3,0 m	31,1	1247	1130	 4 1,2 m	5,9 m	34,0	1794	1180
 3 1,2 m	5,9 m	28,1	944	829	 3 1,2 m	5,9 m	28,1	1287	1169	 3 1,2 m	5,9 m	28,1	1258	910
 2 1,2 m	5,9 m	22,2	865	765	 2 1,2 m	5,9 m	22,2	959	848	 2 1,2 m	5,9 m	22,2	523	413
 +1 1,2 m	5,9 m	16,3	758	645	 +1 1,2 m	5,9 m	16,3	901	836	 +1 1,2 m	5,9 m	16,3	475	375
 +1 TP 12/15	4,0 m				 +1 TP 12/15	4,0 m				 +1 TP 12/15	4,0 m			

**HR**  Main bearing level / Altezza ralla / Hauteur couronne / Drehsattel Höhe /  
 ВЫСОТА УПОРНОГО ПОДШИПНИКА



For different heights contact the technical department / Per altezze diverse contattare l'ufficio tecnico / Pour des hauteurs différentes contacter le département technique / Für unterschiedliche Höhen Kontakt zum Technischen / Недопустимо увеличение высоты крана без согласования с технической службой производителя



Position of next anchor to increase height under hook / Posizione prossimo ancoraggio per aumento altezza sotto gancio / Position du prochain ancrage pour augmenter la hauteur sous crochet / Lage nächste Verankerung zur Erhöhung unter dem Haken / положение для следующего якоря большей высоты под крюком



Anchor position / Posizione d'ancoraggio / Position de ancrage / Verankerungsposition / позицию анкеровки

**FEM 1.001**

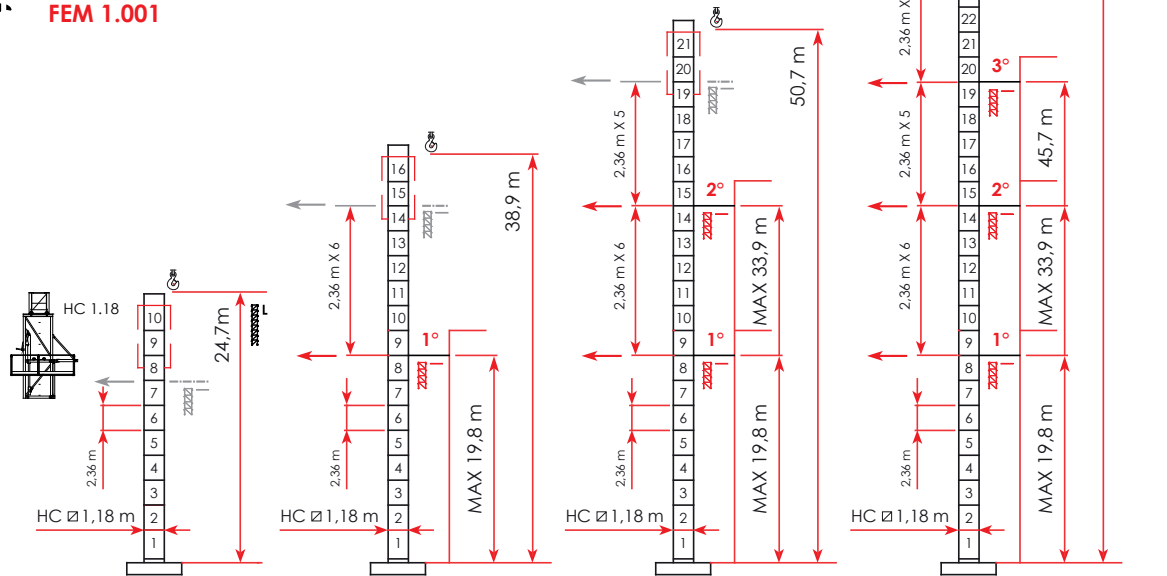

For different heights contact the technical department / Per altezze diverse contattare l'ufficio tecnico / Pour des hauteurs différentes contacter le département technique / Für unterschiedliche Höhen Kontakt zum Technischen / Недопустимо увеличение высоты крана без согласования с технической службой производителя







Position of next anchor to increase height under hook / Posizione prossimo ancoraggio per aumento altezza sotto gancio / Position du prochain ancrage pour augmenter la hauteur sous crochet / Lage nächste Verankerung zur Erhöhung unter dem Haken / положение для следующего якоря большей высоты под крюком



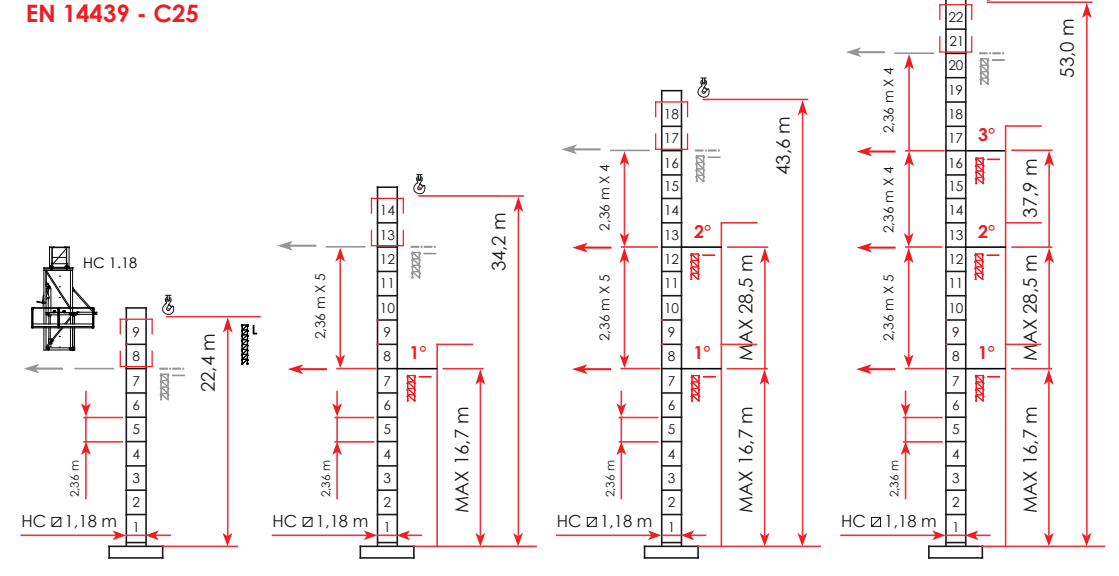



Anchor position / Posizione d'ancoraggio / Position de ancrage / Verankerungsposition / позицию анкеровки

**EN 14439 - C25**

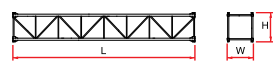
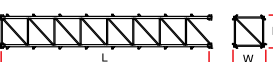

Description	Item	Pz	Drawing	Dimension ( m )			Weight ( kg )	
				n.	n°	l	w	h
<b>Jib element</b> Elemento freccia Elément de flèche Auslegerelement jib section Секция стрелы	1	1		5,115	1,170	1,085	3810	-
	1	1		11,955	1,100	1,060	760	-
	1	1		6,080	1,100	1,060	370	-
	1	1		6,080	1,100	1,060	370	-
	1	1		11,540	1,100	1,060	770	-
<b>A frame / Cuspide /</b> Ponte / Höcker / Шпиль	2			10,800	1,180	2,140	2175	-
<b>Machinery deck</b> Plancia macchinari Plateforme des mécanisme Maschinen Standort Приборная панель оборудования	3			7,610	2,100	2,285	5310	-
<b>Access balcony, cabin /</b> Ballatoio cabina, cabina / Porte cabine / Kabine Podest, Kabine / Платформа кабины, кабина	4			2,585	1,045	2,105	490	-
<b>Counterweight block /</b> Blocchi di contrappeso / Contre - poids / Gegengewichts Blöcke / Блоки противовеса	5	4		<b>A LR60</b> 1,000	0,260	2,390	1170	4680
		2		<b>B LR60</b> 1,000	0,170	2,390	766	1532

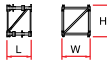
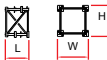
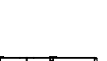
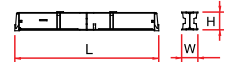
Description	Item	Pz	Drawing	Dimension ( m )			Weight ( kg )	
				n.	n°	l	w	h
				<b>CITY 1,2</b> 5,90	1,200	1,380	1610	-
				<b>CITY 1,5</b> 5,90	1,500	1,700	2070	-
				<b>HC 1,18</b> 2,360	1,180	1,180	870	-
<b>Tower element / Elementi di torre /</b> Elément de mature / Turmstück / Башенные секции	6			<b>CITY 1,2</b> 11,80	1,200	1,380	3050	-
				<b>CITY 1,5</b> 11,80	1,500	1,700	3870	-
				<b>HC 1,18</b> 11,80	1,180	1,180	3350	-
	1			<b>CITY 1,2</b> 1,090	1,440	1,440	485	-
<b>Expendable foundation element /</b> Tronchetto di fondazione / Elément a sceller / Fundamentanker / Анкер	7	1		<b>CITY 1,5</b> 1,465	1,780	1,780	795	-
	1			<b>HC 1,18</b> 1,350	1,490	1,490	790	-
				<b>CITY 1,2</b>	<b>3,8 x 3,8 m</b>			
				5,720	0,670	0,650	1560	-
<b>Base main beam / Trave principale cro-</b> ciera di base / Poutre de chassis de base / Haupt-träger für Kreuzbase / Главная балка крестовины основания	8	1		<b>CITY 1,5</b> 6,530	0,710	0,760	2450	-

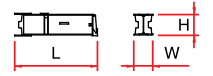
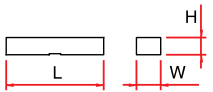
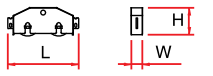
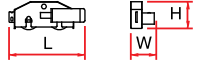
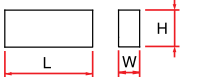
Description	Item	Pz	Drawing	Dimension ( m )			Weight ( kg )			
				n.	n°	l	w	h	Unit	Total
<b>Half base beam /</b> Semitrave di base / Semipoutre de chassis de base / Halb-träger für Kreuzbase / Полубалка основания	9	2		<b>CITY 1,2</b>	<b>3,8 x 3,8 m</b>			750	1500	
				<b>CITY 1,5</b>	<b>4,5 x 4,5 m</b>			1090	2180	
<b>Concrete pad /</b> Blocco di appoggio / Sabot en béton / Beton Fuß / Опорный блок	10	4		<b>CITY 1,2</b>	<b>B1</b>	3,000	0,600	0,600	2465	9860
				<b>CITY 1,5</b>	<b>B2</b>	3,600	0,800	0,600	3925	15700
<b>Driving bogie /</b> Bilancino di traslazione folle/ Boggie fou / Schaukel Bewegung - Neutralstellung / Не приводной балансир	11	2		<b>CITY 1,2</b>	0,800	0,195	0,385	190	380	
				<b>CITY 1,5</b>	1,080	0,230	0,515	415	830	
<b>Driven bogie /</b> Bilancino di traslazione motorizzato / Boggie motorisée / Schau- kel Bewegung - Betriebene / Приводной балансир	12	2		<b>CITY 1,2</b>	0,925	0,425	0,385	310	620	
				<b>CITY 1,5</b>	1,550	0,500	0,515	535	1070	
<b>Base ballast block /</b> Blocco di zavorra / Lest de base / Grundballast / блок балласта	13	-		<b>CITY 1,5</b>	<b>GB3</b>	3,600	1,200	0,300	2950	-
				<b>A</b>	3,000	1,200	0,600	4953	-	

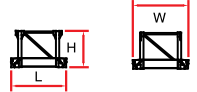
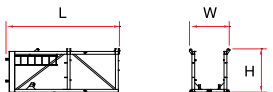
Description	Item	Pz	Drawing	Dimension ( m )			Weight ( kg )	
				n.	n°	l	w	h
<b>Climbing cage connection frame /</b> Telaio di raccordo a spinta / Elément de telescopage / Verbindungsrahmen und drücken / Переходной элемент	14			<b>HC - 1,18</b>			600	-
<b>Climbing Cage /</b> Gabbia di montaggio / Semipoutre de chassis de base / Montagekäfig	15			<b>HC - 1,18</b>			3000	-



3 x 13,60 m

LR60\_Jib 00 m • H 24,0 m + Cabina

Top part / Parte rotante / Partie tournante / Drehender Kranteil / Поворотная часть



2 x 40 High cube

2 x 40 Open Top

 Included counter weight and cabin / Cabina e contrappesi inclusi / Cabine et  
 contrepoids inclus / Kabine und Gegengewichts Blöcke – inbegriffen / Противовес  
 включен - кабина











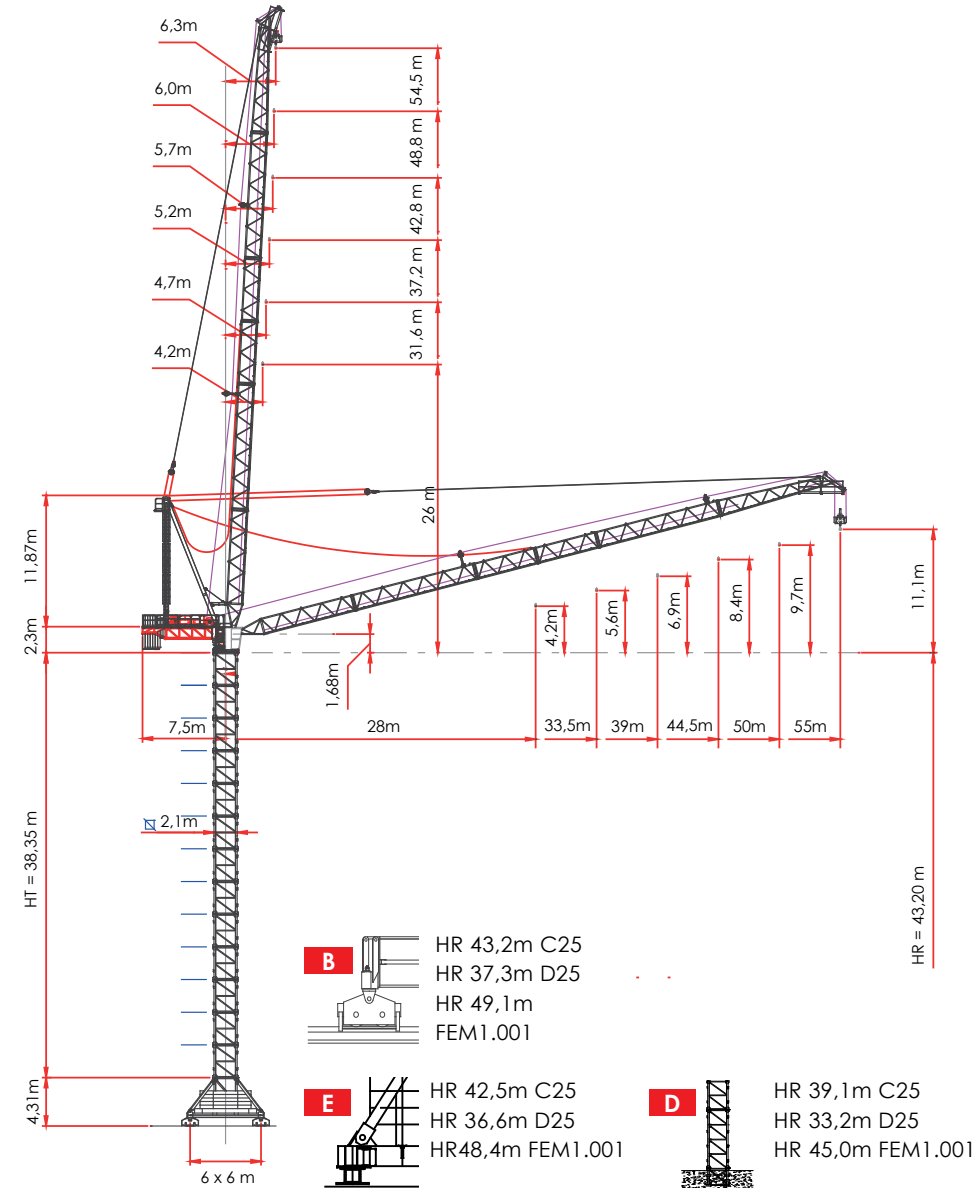









The Raimondi LR213 luffing jib crane has the capacity to carry 1,000 meters of rope on its drum allowing for a lifting capacity of 14 tonnes in four falls at a working height of 250 meters

 **RAIMONDI**® LR213  
SINCE 1863

**HR** Main bearing level  
Altezza ralla  
Hauteur couronne  
Drehsattel Höhe  
Высота упорного  
ПОДШИПНИКА



   2000/14/CE  
A4 EN 14439 C25 D25 - FEM 1.001

IT	EN	F	DE	RU
 Altezza sotto gancio	Height under hook	Hauteur sous crochet	Höhe unter dem Haken	Высота под крюком
 Contrappesi	Counter weight jib ballast	Lest de contre-flèche	Gegenauslegerballast	Противовесы
 Freccia	Jib	Flèche	Kranarm	стрела крана
 Carico massimo	Max load	Charge maximale	Maximale Belastung	максимальная нагрузка
 Curva di carico Ultralift	Load diagrams with ultralift control	Courbes de charges Ultralift	Lastkurven Ultralift	Кривой Груз Ultralift
 Altezza libera	Free Standing	Hauteur libre	Freistehend	Свободностоящая высота
 Azionamenti	Mechanisms	Mécanismes	Antriebe	Приводы
 Velocità	Speed	Vitesse	Geschwindigkeit	скорость
 5* 5 marce con velocità proporzionale al carico	5 step with speed proportional to the load	5 rapports avec une vitesse proportionnelle à la charge	5 Gang Geschwindigkeit proportional zum Last	Автоматический выбор скорости механизма подъема в зависимости от величины груза
 Tiro a 2 funi	Two - rope pull	Tir à deux câbles	Zug an zwei Seilen	Двукратная запасовка тросов
 Tiro a 4 funi	Four - rope pull	Tir à quatre câbles	Zug an vier Seilen	Четырехкратная запасовка тросов
 Totale metri fune tamburo	Total meters rope drum	Total des mètres de corde du tambour	Total Meter Seil Trommel	Запас троса на барабане в метрах
 Diametro fune	Rope diameter	Diamètre du câble	Seildurchmesser	Диаметр троса
 Rotazione	Slewing	Orientation	Schwenken	Поворот
 Braccio impennabile	Luffing jib	Flèche rélevable	Arm mit erhöht	Стрела крана подъемный
 Traslazione	Travelling	Translation	Kranfahren	Перемещение крана





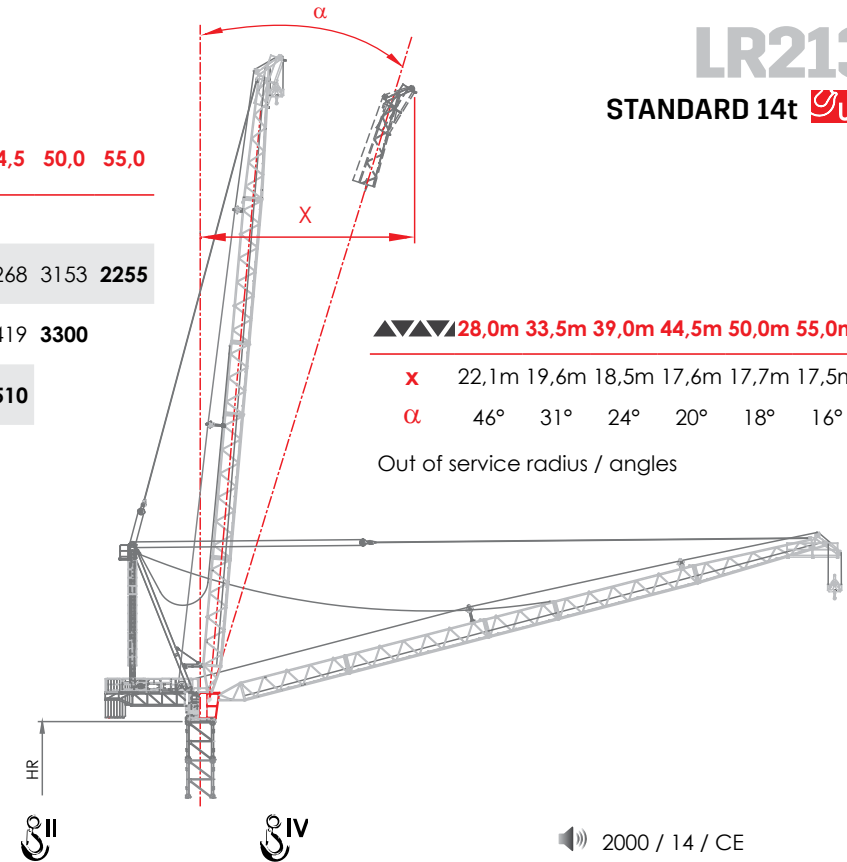

   **28,0 33,5 39,0 44,5 50,0 55,0**

kg	m	14,0t	Kg					
21749	<b>55,0</b>	20,0m	8639	7000	5708	4268	3153	<b>2255</b>
21749	<b>50,0</b>	22,0m	9764	7211	5869	4419	<b>3300</b>	
21749	<b>44,5</b>	22,3m	9886	7346	5859	<b>4510</b>		
21749	<b>39,0</b>	22,4m	10094	7508	<b>6050</b>			
18642	<b>33,5</b>	22,5m	10287	<b>7700</b>				
18642	<b>28,0</b>	23,0m	<b>10450</b>					



 400 V ± 5% 50 Hz    2000 / 14 / CE

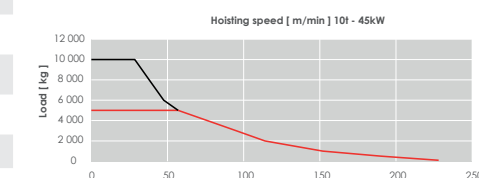

**14 t 75 hp 55 kW**

STEP					
	m/min	kg	m/min	kg	
 650 m	1	8	7000	4	14000
 000 kVA	2	24	7000	12	14000
 Ø 14 mm	3	40	7000	20	14000
	4	64	3600	32	7200
	5	80	2500	40	5000
<b>5*</b>	104	0 - 1000	52	0 - 2000	



kVA Power required / Potenza richiesta / Puissance requise / Erforderliche Leistung / Потребляемая мощность

\*  880 m Optional

 0 / 0,75 r.p.m. ▪ 2 x 4 kW /  14,5° / 85° 1,9 / 0,7 m/min ▪ 55 kW /  18 m/min ▪ 4 x 4 kW

**14 t 100 hp 73,5 kW**  
 CON FRENO DI EMERGENZA

STEP



m/min

kg

m/min

kg

* 500 m	1	8	7000	4	14000
000 kVA	2	30	7000	15	14000
Ø 16 mm	3	52	7000	26	14000
	4	92	3750	46	7500
	5	136	2500	68	5000

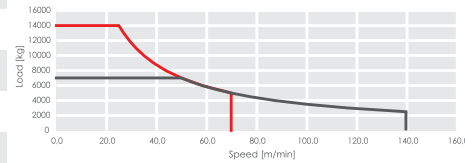

kVA Power required / Potenza richiesta / Puissance requise / Erforderliche Leistung / Потребляемая мощность

\* 1000 m Optional

\* Speed automatically controlled by a current sensor / Velocità regolata automaticamente da sensore di corrente / Vitesse réglée automatiquement par capteur de courant / Automatisch durch Stromsensor geregelte Geschwindigkeit / Скорость автоматически контролируется датчиком напряжения

0 / 0,75 r.p.m. • 2 x 4 kW / 14,5° / 85° 1,9 / 0,7 m/min • 55 kW / 18 m/min • 4 x 4 kW



	JIB	28,0	33,5	39,0	44,5	50,0	55,0
Tip load 14t ▶		23,0	22,5	22,4	22,3	22,0	20 m
22		14000	14000	14000	13990	14000	14000
22,5		14000	14000	13833	13575	13650	13599
24		13473	13016	12661	12402	12437	12363
<b>28</b>		<b>10450</b>	10485	10167	9920	9877	9756
30			9431	9162	8928	8858	8720
32			8450	8272	8058	7968	7816
<b>33,5</b>			<b>7700</b>	7666	7475	7372	7213
34				7471	7287	7182	7000
35				7096	7000	7000	7000
<b>39</b>				<b>6050</b>	6039	5956	5806
40					5749	5671	5520
43					4925	4886	4741
44					4652	4645	4503
<b>44,5</b>					<b>4510</b>	4528	4389
45						4411	4275
46						4184	4056
47						3962	3845
48						3743	3642
49						3525	3445
<b>50</b>						<b>3300</b>	3253
51							3067
53							2706
<b>55</b>							<b>2255</b>

LR213 - 14.0t / 7.0t

**ULTRALIFT** If the crane is not equipped with Ultralift control, all intermediate loads are decreased by 10% / Senza il sistema Ultralift tutte le portate intermedie diminuiscono il carico del 10% / Les charges intermédiaires sont diminuées de 10% si la grue n'est pas équipée d'un contrôle Ultralift. / Mit dem ULTRALIFT-System erhöhen alle Zwischenbelastbarkeiten die Last um 10% / Без ULTRALI FT промежуточный вес уменьшается на 10%.

**B** 2,1 m L = 6,0 m

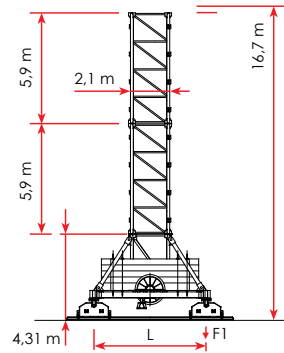

**E** 2,1 m L = 6,0 m

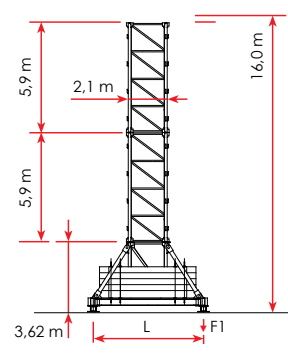

**D** 2,1 m

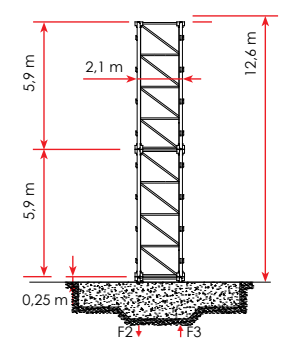

- |                             |                           |                          |                              |                            |
|-----------------------------|---------------------------|--------------------------|------------------------------|----------------------------|
| <b>B</b> Travelling base    | Base traslante            | Grue à traslation        | Fahrbarer Kran               | Кран передвижной           |
| <b>E</b> Base on steel pads | Base con piedi regolabili | Grue sur pieds réglables | Kran auf verstellbaren Füßen | Кран на регулируемых лапах |
| <b>D</b> Crane on embedded  | Grù su tronchetto         | Grue sur plinthe         | Kran auf Fundamentplatte     | Кран на фундаменте         |

**B** 2,1 m - L = 6,0 m

	EN 14439 - C25				EN 14439 - D25				FEM 1.001			
	ΔH (m)	HR (m)	Z** (t)	F1 (kN)	ΔH (m)	HR (m)	Z** (t)	F1 (kN)	ΔH (m)	HR (m)	Z** (t)	F1 (kN)
7	2,95 m	43,2	151,4	1116	-	-	-	-	-	-	-	-
6	2,95 m	40,3	138,5	1009	2,95 m	37,3	144,9	1177	2,95 m	49,1	151,5	1208
5	2,95 m	37,3	119,1	897	2,95 m	34,4	125,5	1012	5,9 m	46,2	138,5	1089
4	2,95 m	34,4	102,9	797	2,95 m	31,4	109,4	892	5,9 m	40,3	119,1	866
3	2,95 m	31,4	83,5	693	2,95 m	28,5	96,5	792	5,9 m	34,4	102,9	772
2	5,9 m	28,5	70,6	656	2,95 m	25,5	77,1	680	5,9 m	28,5	83,5	702
+1	5,9 m	22,6	51,2	565	5,9 m	22,6	70,6	659	5,9 m	22,6	70,6	665

STANDARD 2,1 HC5S 14t

**E** 2,1 m - L = 6,0 m

	EN 14439 - C25				EN 14439 - D25				FEM 1.001			
	ΔH (m)	HR (m)	Z** (t)	F1 (kN)	ΔH (m)	HR (m)	Z** (t)	F1 (kN)	ΔH (m)	HR (m)	Z** (t)	F1 (kN)
7	2,95 m	42,5	151,4	1085	-	-	-	-	-	-	-	-
6	2,95 m	39,6	138,5	980	2,95 m	36,6	144,9	1131	2,95 m	48,4	151,5	1165
5	2,95 m	36,6	119,1	869	2,95 m	33,7	125,5	972	5,9 m	45,5	138,5	1057
4	2,95 m	33,7	102,9	769	2,95 m	30,7	109,4	860	5,9 m	39,6	119,1	890
3	2,95 m	30,7	83,5	677	2,95 m	27,8	96,5	762	5,9 m	33,7	102,9	752
2	5,9 m	27,8	70,6	640	2,95 m	24,8	77,1	651	5,9 m	27,8	70,6	650
+1	5,9 m	21,9	51,2	556	5,9 m	21,9	70,6	630	5,9 m	21,9	51,2	651

**Z\*\***  Comply with the specified ballast Z(t) / Attenersi alla zavorra indicata Z(t) / S'en tenir au lest indiqué Z(t) / Unbedingt die angegebenen Ballastwerte einhalten Z(t) / Соблюдать указанный балласт Z(t)

**D** 2,1 m

	EN 14439 - C25				EN 14439 - D25				FEM 1.001			
	ΔH (m)	HR (m)	F2 (kN)	F3 (kN)	ΔH (m)	HR (m)	F2 (kN)	F3 (kN)	ΔH (m)	HR (m)	F2 (kN)	F3 (kN)
7	2,95 m	39,1	1527	1172	-	-	-	-	-	-	-	-
6	2,95 m	36,2	1333	986	2,95 m	33,2	1619	1280	2,95 m	45,0	1695	1325
5	2,95 m	33,2	1177	838	2,95 m	30,3	1397	1067	5,9 m	42,1	1525	1163
4	2,95 m	30,3	1095	713	2,95 m	27,3	1219	898	5,9 m	36,2	1403	990
3	2,95 m	27,3	1053	683	2,95 m	24,4	1030	718	5,9 m	30,3	1309	913
2	5,9 m	24,4	1013	655	2,95 m	21,4	975	630	5,9 m	24,4	1225	847
+1	5,9 m	18,5	940	606	5,9 m	18,5	940	606	5,9 m	18,5	1187	817



2,1 m Booster **D**

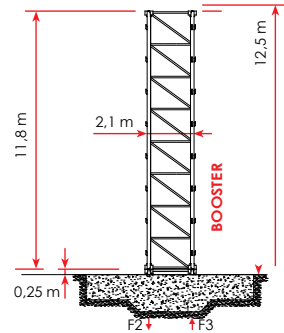

**D** 2,1 m

**BOOSTER 2,1 HC5S 14t**

EN 14439 - C25					EN 14439 - D25					FEM 1.001					
$\Delta H$ (m)	HR (m)	F2 (kN)	F3 (kN)		$\Delta H$ (m)	HR (m)	F2 (kN)	F3 (kN)		$\Delta H$ (m)	HR (m)	F2 (kN)	F3 (kN)		
5	-	-	-	-	6	-	-	-	-	3	2,95 m	56,8	2554	2172	
4	-	-	-	-	5	-	-	-	-	2	2,95 m	53,9	2240	1866	
3	2,95 m	50,9	2307	1914	4	-	-	-	-	+1	2,95 m	51,0	2042	1678	
2	2,95 m	48,0	2061	1676	3	-	-	-	-	+12	2,95 m	48,0	1854	1498	
+1	2,95 m	45,0	1864	1488	2	2,95 m	42,1	2272	1905						
+10	2,95 m	42,1	1651	1284	+1	2,95 m	39,2	2004	1646						
...					+8	2,95 m	36,2	1790	1440						

**HR** Main bearing level / Altezza ralla / Hauteur couronne / Drehsattel Höhe / Высота упорного подшипника

**For different heights contact the technical department / Per altezze diverse contattare l'ufficio tecnico / Pour des hauteurs différentes contact le département technique / Für unterschiedliche Höhen Kontakt zum Technischen / Недопустимо увеличение высоты крана без согласования с технической службой производителя**

**Position of next anchor to increase height under hook / Posizione prossimo ancoraggio per aumento altezza sotto gancio / Position du prochain ancrage pour augmenter la hauteur sous crochet / Lage nächste Verankerung zur Erhöhung unter dem Haken / положение для следующего якоря большей высоты под крюком**

**Anchor position / Posizione d'ancoraggio / Position de ancrage / Verankerungsposition / позицию анкеровки**

**FEM 1.001**

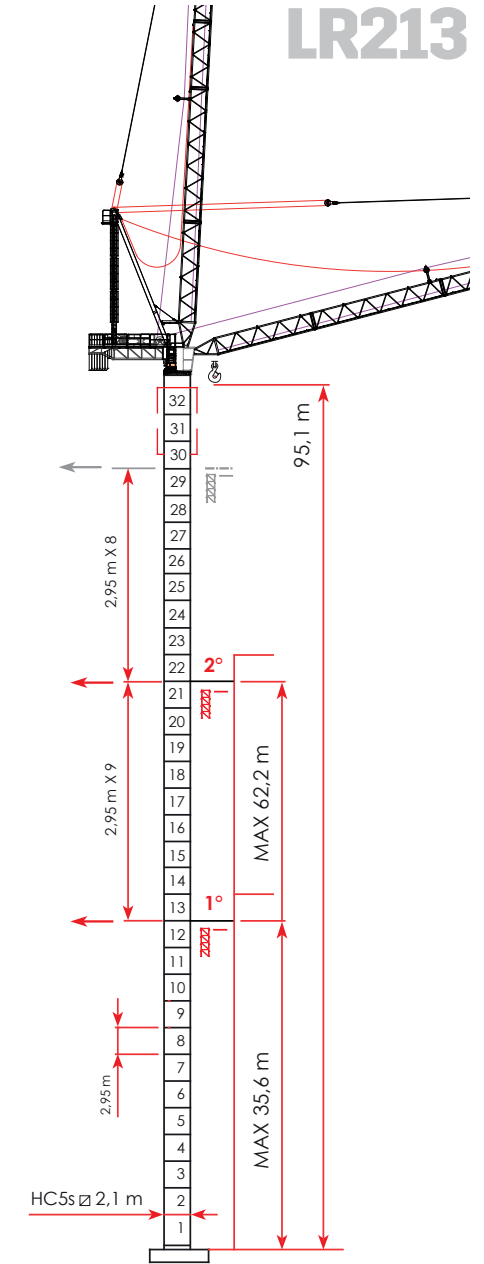
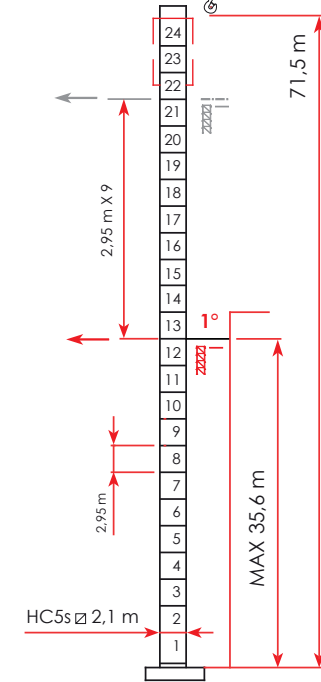
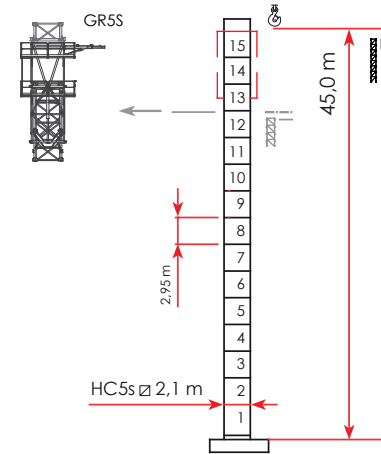

**Climbing crane / Sopralzo idraulico / Télescopage sur dalles / Kletterkrane im Gebäude / Кран поднимающийся на плитах перекрытия**



For different heights contact the technical department / Per altezze diverse contattare l'ufficio tecnico / Pour des hauteurs différentes contact le département technique / Für unterschiedliche Höhen Kontakt zum Technischen / Недопустимо увеличение высоты крана без согласования с технической службой производителя



Position of next anchor to increase height under hook / Posizione prossimo ancoraggio per aumento altezza sotto gancio / Position du prochain ancrage pour augmenter la hauteur sous crochet / Lage nächste Verankerung zur Erhöhung unter dem Haken / положение для следующего якоря большей высоты под крюком



Anchor position / Posizione d'ancoraggio / Position de ancrage / Verankerungsposition / позицию анкеровки



**EN 14439 - C25**

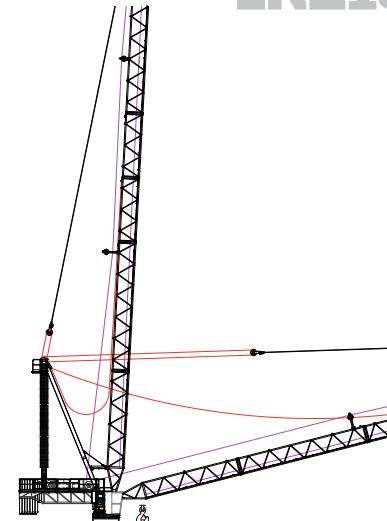
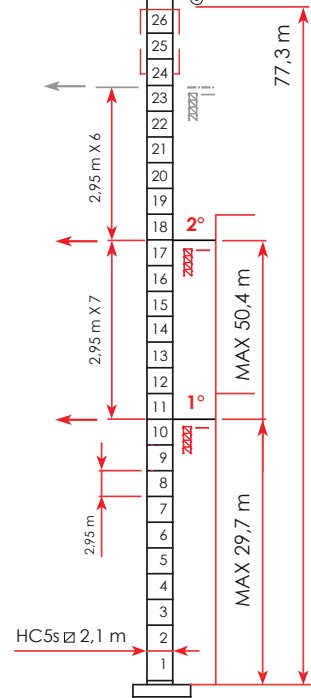
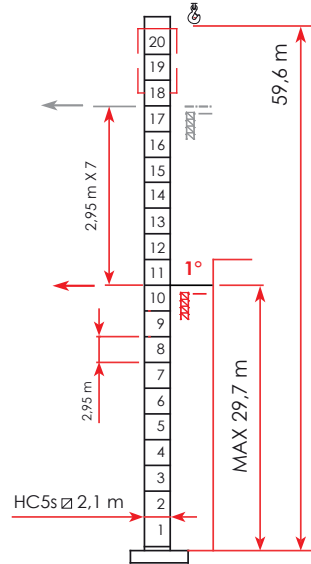
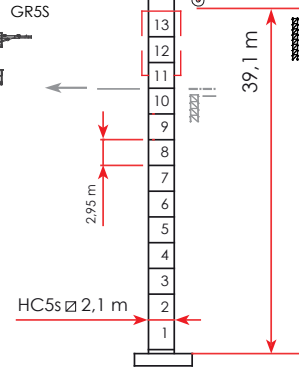
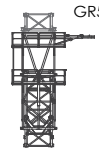

## Description

### Jib element

Elemento freccia

Élément de flèche

Auslegerelement jib section

Секция стрелы

### A frame inclined panel

Pannello anteriore cavalletto

Panneau antérieur du porte - flèche

Frontstandpanel

Передняя панель козел

### A frame vertical panel

Tirante posteriore cavalletto

Panneau vertical du porte - flèche

Rückstativstange

Задняя тяга козел

### Machinery deck



Plancia macchinari



Plateforme des mécanisme

Maschinen Standort

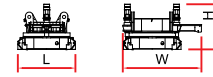
Приборная панель оборудования

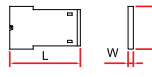
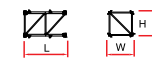
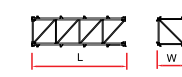
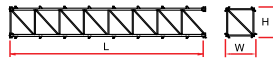
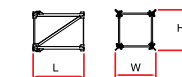
Description	Item n.	Pz n°	Drawing	Dimension ( m )			Weight ( kg )	
				l	w	h	Unit	Total
Elemento freccia	1	el 1		11,370	1,620	1,600	1390	-
Élément de flèche		el 2		11,465	1,395	1,600	1240	-
Auslegerelement jib section		el 3 el 3a		5,785	1,395	1,600	650	-
Секция стрелы		el 4		11,465	1,395	1,600	1240	-
		el 5		11,610	1,395	2,200	1360	-
Pannello anteriore cavalletto	2			11,965	0,435	1,700	-	1935
Panneau antérieur du porte - flèche								
Frontstandpanel								
Передняя панель козел								
Tirante posteriore cavalletto	3			11,740	0,750	1,715	-	1217
Panneau vertical du porte - flèche								
Rückstativstange								
Задняя тяга козел								
Plancia macchinari	4			8,345	1,800	2,335	-	9850
Plateforme des mécanisme								
Maschinen Standort								
Приборная панель оборудования								
				8,345	1,800	2,335	-	10800

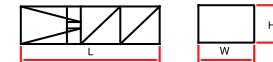
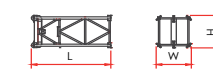
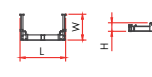
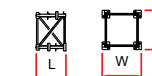
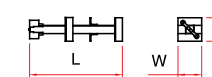
Description	Item	Pz	Drawing	Dimension ( m )			Weight ( kg )		
				n.	n°	l	w	h	Unit
<b>Slewing table</b> / Gruppo girevole / Table tournante / Rotierende Gruppe / Вращения	<b>5</b>	1		<b>HC5s</b>	2,30	3,15	1,90	-	5400
<b>Access balcony, cabin</b> / Ballatoio cabina, cabina / Porte cabine / Kabine Podest, Kabine / Платформа кабины, кабина	<b>6</b>	1			2,47	3,53	2,19	-	1600
<b>Counterweight block</b> Blocchi di contrappeso Contre - poids Gegengewichts Blöcke Блоки противовеса	<b>7</b>	7		<b>A LR213</b>	3,140	0,225	1,825	3107	-
<b>Tower element</b> / Elementi di torre / Elément de mature / Turmstück / Башенные секции	<b>8</b>			<b>HC5S</b>	2,95	2,300	2,300	1900	-
	<b>9</b>			<b>HC5S</b>	5,90	2,300	2,300	3450	-
	<b>10</b>			<b>HC5S</b>	11,80	2,300	2,300	5920	-
<b>Base element</b> Elemento di base Mat de base Turmstück Элемент основания	<b>11</b>				3,000	2,400	2,400	1950	-

Description	Item	Pz	Drawing	Dimension ( m )			Weight ( kg )		
				n.	n°	l	w	h	Unit
<b>Climbing Cage</b> / Gabbia di montaggio / Semipoutre de chassis de base / Montagekäfig	<b>12</b>			<b>HC5S - 2,1</b>	8,530	3,100	2,300	7670	-
<b>Floor climbing elements</b> /	<b>18</b>				4,680	2,300	2,300	2.940	-
					2,730	1,560	0,500	715	-
<b>Expendable foundation element</b> / Tronchetto di fondazione / Elément a sceller / Fundamentanker / Анкер	<b>13</b>	1			1,820	2,400	2,400	1370	
<b>Fixing angles</b> / gambe di fondazione / pieds de scellement / Säulen der Stiftung / ножки основания	<b>14</b>	4			1,820	0,470	0,470	280	1120
<b>Base main beam</b> / Trave principale crociera di base / Poutre de chassis de base / Haupt-träger für Kreuzbase / Главная балка крестовины основания	<b>15</b>	1			8,900	0,720	0,760	1650	-
<b>Half base beam</b> / Semitrave di base / Semipoutre de chassis de base / Halb-träger für Kreuzbase / Полубалка основания		2			4,350	0,600	0,760	750	1500

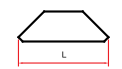
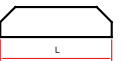

Description	Item	Pz	Drawing	Dimension ( m )			Weight ( kg )	
	n.	n°		l	w	h	Unit	Total
Driven bogie / Bilancino di traslazione motorizzato / Boggie motorisèe / Schaukel Bewegung - Betriebene / Приводной балансир	16	4		1,750	0,705	0,790	1000	4000
Base ballast block / Blocco di zavorra / Lest de base / Grundballast / блок балласта	17			4,200	0,320	1,400	3230	-
				5,200	0,400	1,400	6240	-



6 x 13,60 m  
1 x 4,00 m

LR 165 HC \_Jib 55 m • HUH 0,0 m

Top part / Parte rotante / Partie tournante / Drehender Kranteil / Поворотная часть



2 x 40 Open Top

Included counter weight and cabin / Cabina e contrappesi inclusi / Cabine et contrepoids inclus / Kabine und Gegengewichts Blöcke – inbegriffen / Противовес включен - кабина

1 x 20 Box

5 x 40 Box



Two Raimondi LR213 luffing cranes at work in Dubai, UAE

LR213 luffing cranes assembled in Legnano, Milan - Italy





The Raimondi LR273 luffing jib crane boasts many optimizations including excellent load curve and big drum capacity, and is celebrated for its ease of use and efficient installation procedure









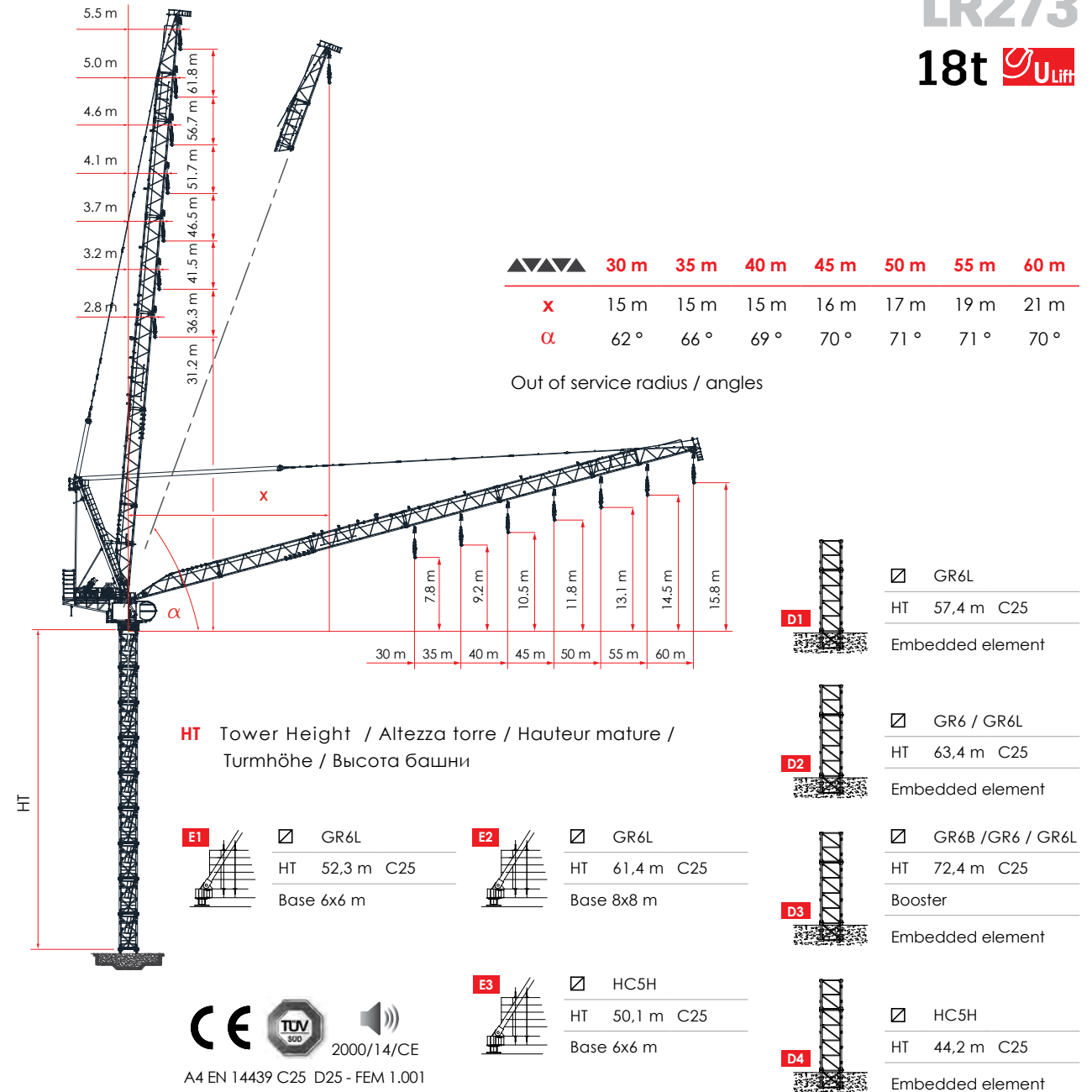







# RAIMONDI<sup>®</sup> LR273



SINCE 1863

# LR273

## 18t



IT	EN	F	DE	RU
 Altezza sotto gancio	Height under hook	Hauteur sous crochet	Höhe unter dem Haken	Высота под крюком
 Contrappesi	Counter weight jib ballast	Lest de contre-flèche	Gegenauslegerballast	Противовесы
 Freccia	Jib	Flèche	Kranarm	стрела крана
 Carico massimo	Max load	Charge maximale	Maximale Belastung	максимальная нагрузка
 <b>U</b> Curva di carico Ultralift	Load diagrams with ultralift control	Courbes de charges Ultralift	Lastkurven Ultralift	Кривой Груз Ultralift
 Altezza libera	Free Standing	Hauteur libre	Freistehend	Свободностоящая высота
 Azionamenti	Mechanisms	Mécanismes	Antriebe	Приводы
 Velocità	Speed	Vitesse	Geschwindigkeit	скорость
 5 marce con velocità proporzionale al carico	5 step with speed proportional to the load	5 rapports avec une vitesse proportionnelle à la charge	5 Gang Geschwindigkeit proportional zum Last	Автоматический выбор скорости механизма подъема в зависимости от величины груза
 Tiro a 2 funi	Two - rope pull	Tir à deux câbles	Zug an zwei Seilen	Двукратная запасовка тросов
 Tiro a 4 funi	Four - rope pull	Tir à quatre câbles	Zug an vier Seilen	Четырехкратная запасовка тросов
 Totale metri fune tamburo	Total meters rope drum	Total des mètres de corde du tambour	Total Meter Seil Trommel	Запас троса на барабане в метрах
 Diametro fune	Rope diameter	Diamètre du câble	Seildurchmesser	Диаметр троса
 Rotazione	Slewing	Orientation	Schwenken	Поворот
 Braccio impennabile	Luffing jib	Flèche rélevable	Arm mit erhöht	Стрела крана подъемный
 Traslazione	Travelling	Translation	Kranfahren	Перемещение крана

 Jib	30 m	35 m	40 m	45 m	50 m	55 m	60 m	 Jib	30 m	35 m	40 m	45 m	50 m	55 m	60 m
9,0t	30 m	35 m	35 m	34 m	33 m	31 m	30 m	18,0t	19,4 m	19,4 m	19,3 m	19 m	19 m	19 m	22,3 m
m				t				m				t			
20	9,00	9,00	9,00	9,00	9,00	9,00	9,00	20	18,00	18,00	18,00	18,00	18,00	16,00	13,50
25	9,00	9,00	9,00	9,00	9,00	9,00	9,00	25	14,89	14,81	14,83	14,43	15,04	13,07	12,78
27	9,00	9,00	9,00	9,00	9,00	9,00	9,00	27	13,55	13,49	13,49	13,10	13,54	11,81	11,49
29	9,00	9,00	9,00	9,00	9,00	9,00	9,00	29	12,35	12,34	12,33	11,94	12,29	10,72	10,38
<b>30</b>	<b>9,00</b>	9,00	9,00	9,00	9,00	9,00	9,00	<b>30</b>	<b>11,77</b>	11,81	11,80	11,42	11,73	10,23	9,88
33		9,00	9,00	9,00	9,00	9,00	8,81	33		10,38	10,40	10,05	10,25	8,93	8,56
<b>35</b>		<b>9,00</b>	9,00	9,00	9,00	8,48	8,07	<b>35</b>		<b>9,51</b>	9,58	9,25	9,41	8,19	7,81
36			9,00	9,00	8,98	8,14	7,73	36			9,20	8,89	9,03	7,85	7,46
38			8,86	8,56	8,32	7,52	7,11	38			8,49	8,21	8,31	7,21	6,82
<b>40</b>			<b>8,20</b>	7,94	7,72	6,96	6,54	<b>40</b>			<b>7,81</b>	7,59	7,67	6,64	6,24
41				7,66	7,43	6,70	6,28	41				7,30	7,37	6,38	5,98
43					7,12	6,91	6,22	43				6,74	6,55	5,88	5,48
<b>45</b>					<b>6,60</b>	6,43	5,77	<b>45</b>				<b>6,22</b>	6,06	5,43	5,02
46						6,20	5,14	46					5,83	5,21	4,81
48						5,76	4,75	48					5,38	4,81	4,41
<b>50</b>						<b>5,34</b>	4,80	<b>50</b>					<b>4,95</b>	4,43	4,03
54							4,12	54						3,74	3,36
<b>55</b>							<b>3,96</b>	<b>55</b>						<b>3,58</b>	3,21
58							3,14	58							2,76
<b>60</b>							<b>2,86</b>	<b>60</b>							<b>2,48</b>

### ULTRALIFT

If the crane is not equipped with Ultralift control, all intermediate loads are decreased by 10% / Senza il sistema Ultralift tutte le portate intermedie diminuiscono il carico del 10%



Jib	30 m	35 m	40 m	45 m	50 m	55 m	60 m
13,5t	25 m	25 m	25 m	24,3 m	24 m	22,4 m	22,3 m
				t			
20	13,50	13,50	13,50	13,50	13,50	13,50	13,50
25	13,50	13,50	13,50	13,50	13,50	13,13	12,82
27	13,50	13,50	13,50	13,20	13,50	11,89	11,55
29	12,51	12,49	12,46	12,06	12,39	10,81	10,45
<b>30</b>	<b>11,94*</b>	11,96	11,94	11,55	11,83	10,33	9,96
33		10,54	10,54	10,18	10,37	9,04	8,66
<b>35</b>		<b>9,68*</b>	9,73	9,39	9,54	8,30	7,91
36			9,36	9,03	9,15	7,97	7,57
38			8,65	8,36	8,45	7,34	6,94
<b>40</b>			<b>7,98*</b>	7,74	7,81	6,78	6,37
41				7,45	7,52	6,51	6,10
43				6,90	6,70	6,02	5,61
<b>45</b>				<b>6,38*</b>	6,21	5,57	5,16
46					5,98	5,36	4,95
48					5,54	4,96	4,55
<b>50</b>					<b>5,12*</b>	4,59	4,18
54					3,90	3,52	
<b>55</b>						<b>3,740*</b>	3,36
58							2,93
<b>60</b>							<b>2,64*</b>

### ULTRALIFT

If the crane is not equipped with Ultralift control, all intermediate loads are decreased by 10% / Senza il sistema Ultralift tutte le portate intermedie diminuiscono il carico del 10%

400 V ± 5%



2000 / 14 / CE

**18 t**  
**90 hp 67 kW**

STEP



	m/min	t	m/min	t	m/min	t
--	-------	---	-------	---	-------	---

980 m	1	10,8	9,00	7,2	13,50	5,4	18,00
258 kVA	2	38	9,00	25,3	13,50	19	18,00
Ø 16 mm	3	72,6	4,50	48,4	6,75	36,3	9,00
	4	108,4	2,80	72,3	4,20	54,2	5,60
	5	141	1,90	94,0	2,85	70,5	3,80
	5*	156,4	1,50	104,3	2,25	78,2	3,00

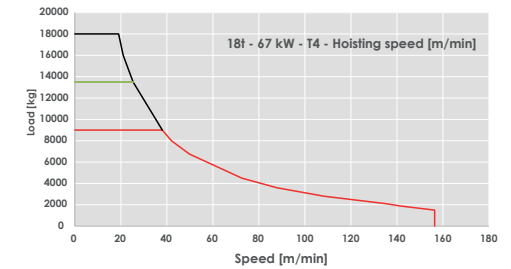

5\* Velocità regolata automaticamente da sensore di corrente / Vitesse réglée automatiquement par capteur de courant / Automatisch durch Stromsensor geregelte geschwindigkeit

400 V ± 5%



2000 / 14 / CE

**18 t**  
**115 hp 86 kW**

STEP



	m/min	t	m/min	t	m/min	t
--	-------	---	-------	---	-------	---

980 m	1	9,2	9,00	6,1	13,50	4,6	18,00
230 kVA	2	47	9,00	32,3	13,50	23,5	18,00
Ø 16 mm	3	94	4,50	64,6	6,75	47	9,00
	4	147	2,50	98,0	3,75	73,5	5,00
	5	175	1,75	116,7	2,6	87,5	3,50
	5*	204	1,10	136,0	1,65	102	2,20

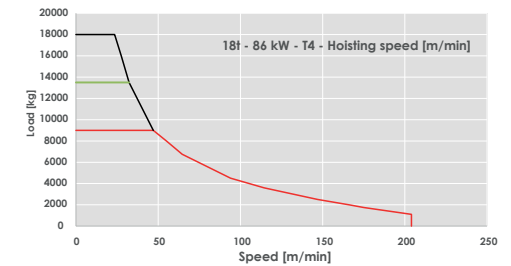

5\* Velocità regolata automaticamente da sensore di corrente / Vitesse réglée automatiquement par capteur de courant / Automatisch durch Stromsensor geregelte geschwindigkeit



0 / 0,8 r.p.m. • 2 x 11 kW /



15° / 85° 1,8 min • 75 kW /



- m/min • \_ x \_ kW

2,3 m GR6L D1

FEM 1.001

Jib [m]	HT [m]
30	66,4
35	63,4
40	60,4
45	60,4
50	57,4
55	54,4
60	54,4

EN 14439 C25

Jib [m]	HT [m]
30	57,4
35	54,4
40	54,4
45	51,4
50	51,4
55	48,4
60	45,4

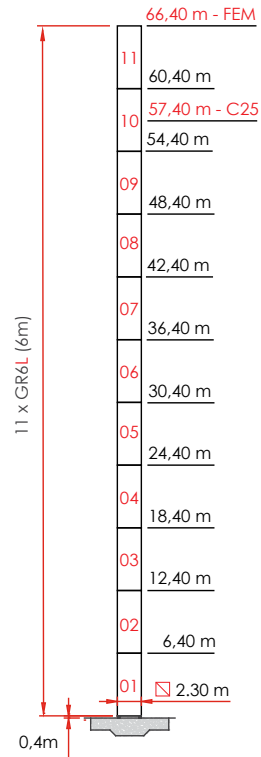

2,3 m GR6 / GR6L D2

FEM 1.001

Jib [m]	HT [m]
30	75,4
35	75,4
40	72,4
45	72,4
50	69,4
55	66,4
60	66,4

EN 14439 C25

Jib [m]	HT [m]
30	63,4
35	63,4
40	63,4
45	60,4
50	57,4
55	57,4
60	54,4

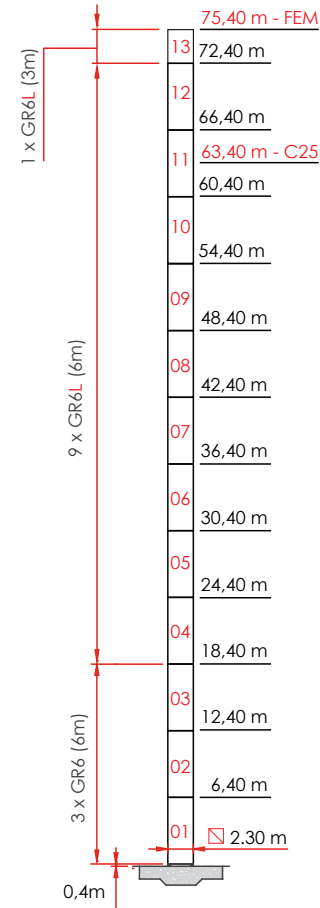

2,3 m GR6B/GR6/GR6L D3

FEM 1.001

Jib [m]	HT [m]
30	84,4
35	84,4
40	81,4
45	81,4
50	78,4
55	78,4
60	75,4

EN 14439 C25

Jib [m]	HT [m]
30	72,4
35	72,4
40	72,4
45	69,4
50	66,4
55	66,4
60	63,4

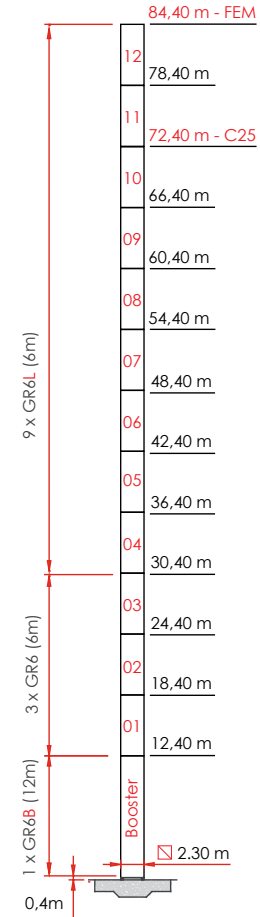

2,3 m GR6L E1

Base 6,0 x 6,0 m FEM 1.001

HT [m]	60m	55m	50m	45m	40m	35m	30m
52,3							196
49,3						188	180 172
46,3					188	180	164 156 148
43,3	196	180	164	156	140	132	124
37,3	148	132	116	108	100	92	84
31,3	100	92	92	76	76	68	60
25,3	68	68	68	60	60	60	60
19,3	60	60	60	60	60	60	60

Base 6,0 x 6,0 m EN14439 C25

HT [m]	60m	55m	50m	45m	40m	35m	30m
52,3							196
49,3						196	180 172
46,3					196	180	164 156 148
43,3	188	164	156	140	132	124	
40,3	180	156	140	132	116	108	100
37,3	148	132	116	108	100	84	84
31,3	100	92	92	84	76	76	68
25,3	76	76	76	68	68	68	60
19,3	60	60	60	60	60	60	60

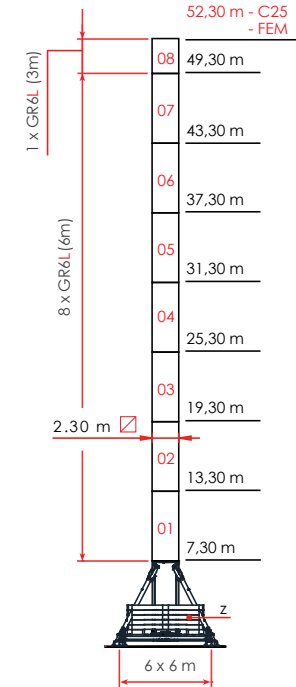

Jib	Jib length	HT (m)	Total tower height	A	Base on concrete pads
B	Travelling base	D	Crane on embedded	E	Base on steel pads

Jib	Jib length	HT (m)	Total tower height	A	Base on concrete pads
B	Travelling base	D	Crane on embedded	E	Base on steel pads



2,3 m GR6L E2

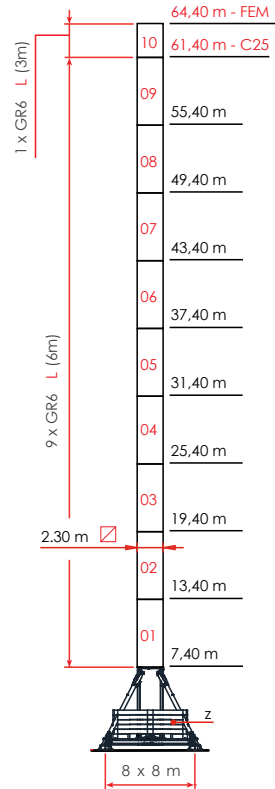

Base 8,0 x 8,0 m FEM 1.001

HT	60m	55m	50m	45m	40m	35m	30m
[m]	Z [t]						
64,4							196
61,4					186	176	176
58,4				176	166	156	146
55,4	196	166	156	146	136	126	126
52,4	176	176	146	136	126	116	106
49,4	156	156	126	116	106	96	96
43,4	116	116	86	76	66	66	56
37,4	76	76	46	46	36	36	36
31,4	46	46	36	36	36	36	36
25,4	36	36	36	36	36	36	36
19,4	36	36	36	36	36	36	36

Base 8,0 x 8,0 m EN14439 C25

HT	60m	55m	50m	45m	40m	35m	30m
[m]	Z [t]						
61,4							196 186
58,4						196	176 166 156
55,4	196	176	166	156	146	136	
52,4	186	176	156	146	136	126	116
49,4	166	146	136	126	106	106	96
43,4	116	106	86	86	76	66	56
37,4	76	66	56	46	36	36	36
31,4	46	36	36	36	36	36	36
25,4	36	36	36	36	36	36	36
19,4	36	36	36	36	36	36	36

Jib	Jib length	HT (m)	Total tower height	A	Base on concrete pads
B	Travelling base	D	Crane on embedded	E	Base on steel pads

1,95 m HC5H D4

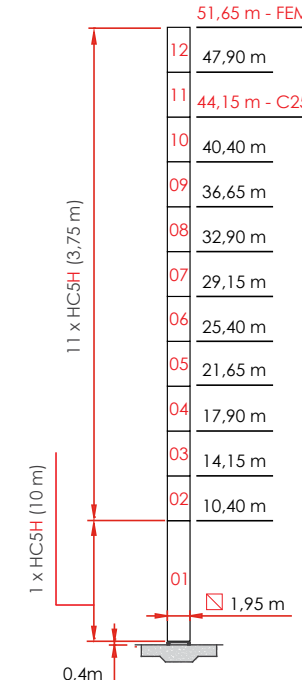

FEM 1.001

Jib [m]	HT [m]
30	51,7
35	51,7
40	47,9
45	47,9
50	44,2
55	44,2
60	44,2

EN 14439 C25

Jib [m]	HT [m]
30	44,2
35	44,2
40	44,2
45	40,4
50	40,4
55	36,7
60	36,7

Jib	Jib length	HT (m)	Total tower height	A	Base on concrete pads
B	Travelling base	D	Crane on embedded	E	Base on steel pads

1,95 m HC5H E3

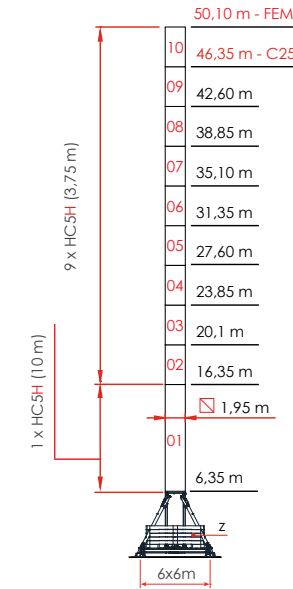

Base 6,0 x 6,0 m FEM 1.001

HT	60m	55m	50m	45m	40m	35m	30m
[m]	Z [t]						
50,1							196 188
46,4					188	172	164 156
42,6				188	172	156	140 132 124
38,9	180	156	140	124	116	108	100
35,1	140	124	116	100	100	84	84
31,4	108	100	100	84	84	76	68
27,6	92	84	84	76	68	68	68
23,9	76	76	76	60	60	68	68
20,1	60	60	60	60	60	68	68

Base 6,0 x 6,0 m EN14439 C25

HT	60m	55m	50m	45m	40m	35m	30m
[m]	Z [t]						
46,4							196 180 172 156
42,6					188	164	156 140 132 124
38,9	172	156	132	124	116	100	92
35,1	140	124	116	100	100	84	84
31,4	108	100	100	84	84	76	68
27,6	84	84	84	76	76	60	60
23,9	76	76	76	60	60	60	60
20,1	60	60	60	60	60	60	60

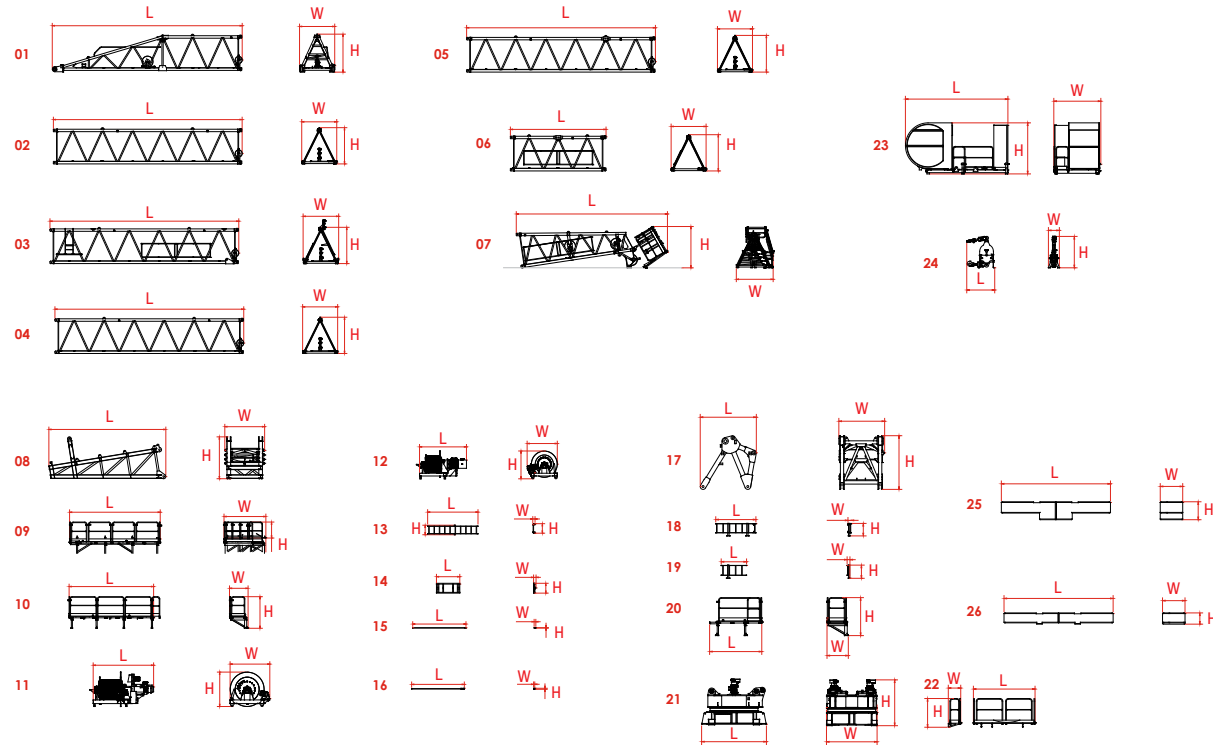

10 x 13,60 m

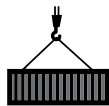
**LR273 \_Jib 60 m ▪**
**Top part / Parte rotante / Partie tournante / Drehender Kranteil / Поворотная часть**

3 x 40 High cube

**Included counter weight and cabin / Cabina e contrappesi inclusi / Cabine et contrepoids inclus / Kabine und Gegengewichts Blöcke – inbegriffen / Противовес включен - кабина**

2 x 40 Open Top



6 x 40 Box

**L (m)** Length of the element

**H (m)** Height of the element

**W (m)** Width of the element

**Kg** Unit weight

## Jib and Counter-jib Elements

## DIMENSIONS [ m ]

UNIT	POS.	QUANTITY	L	W	H	Kg
Jib element*	01	1	10 443	1 933	2 061	2 822
Jib element	02	1	10 383	1 925	1 969	1 480
Jib element*	03	1	10 383	1 953	1 969	1 466
Jib element	04	1	10 383	1 925	1 969	1 369
Jib element	05	1	10 383	1 925	1 992	1 431
Jib element	06	1	5 260	1 925	1 969	845
Jib element	07	1	8 314	2 027	2 243	1 666
Counter-jib	08	1	6 433	2 190	2 273	4 045
Balcony (left side)	09	1	4 984	2 300	2 717	882
Balcony (right side)	10	1	4 684	1 022	1 717	308
Hoisting winch with rope (110 kW)	11	1	3 323	2 183	1 870	6 524
Luffing winch with rope (75 kW)	12	1	2 580	1 660	1 512	3 156
Counterweight access ladder	13	1	2 770	123	516	30
Counterweight fixing system	14	1	1 264	135	534	7
External tie Counterweight	15	1	2 930	94	24	11
internal tie Counterweight	16	1	2 895	65	54	12
A-Frame Support	17	1	2 570	2 100	2 430	3 141
External ladder (left side)	18	1	1 840	145	566	32
External ladder (right side)	19	1	1 160	130	596	18
A-Frame support balcony	20	1	2 390	975	1 717	148
Slewing unit	21	1	2 970	2 320	2 074	10 351
Slewing unit balcony	22	1	2 825	571	1 304	97
Balcony with Cabin and electrical cabin	23	1	4 696	2 155	2 310	2 067
Hook Block	24	1	1 281	500	1 422	675
Counter-weight	2510_01	25	5 000	1 030	810	6 600
Counter-weight	2510_02	26	5 000	1 030	510	5 200

\* With platform and accessories

## A-FRAME PACKING LIST

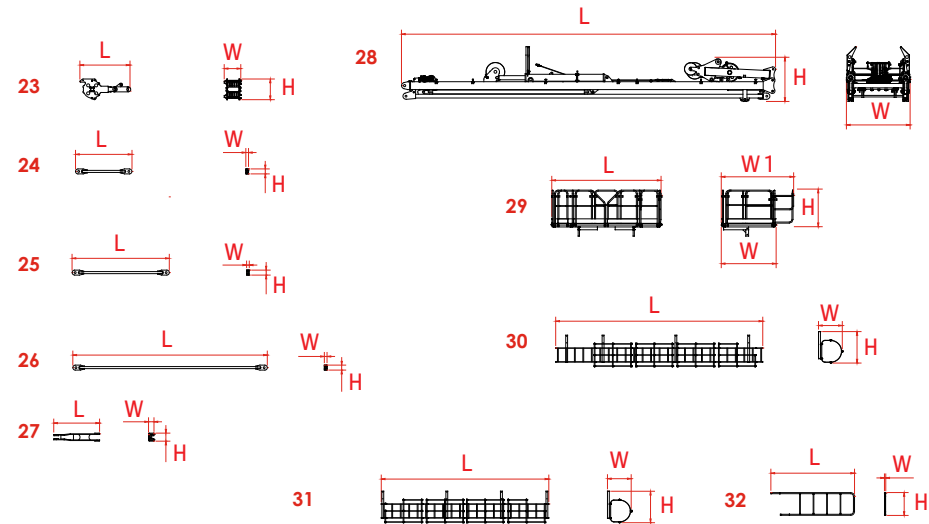

A-Frame Elements		DIMENSIONS [ m ]				UNIT WEIGHT
UNIT	POS.	QUANTITY	L	W	H	Kg
Mobile sheave block for luffing rope	23	1	1 597	660	528	296
Tie short	24	1	1 800	85	160	60
Tie medium	25	3	3 100	85	160	281
Tie long	26	4	6 200	85	160	697
Tie	27	1	1 460	175	255	96
Counter-jib A-frame unit	28	1	11 922	2 030	1 750	5 730
Balcony	29	1	3 485	1 750	1 467	350
Top Ladder	30	1	6 600	757	1 005	135
Bottom Ladder	31	1	5 340	757	1 005	120
Removable handrails	32	1	2 667	43	733	15

## TOWER AND BASE PACKING LIST

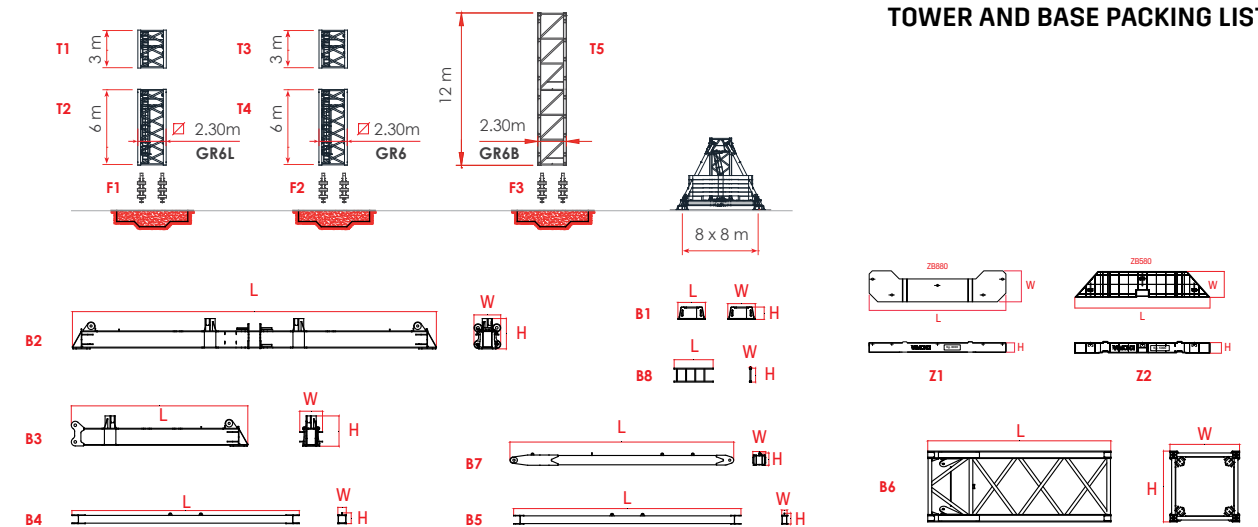

Tower 2,30 m and base package list

UNIT	POS.	QUANTITY	DIMENSIONS [ m ]			UNIT WEIGHT		
			L	W	H	Kg		
Tower element	GR6L	3,0	T1	1	3,000	2,290	2,276	2 680
Tower element	GR6L	6,0	T2	1	6,000	2,290	2,276	4 865
Tower element	GR6	3,0	T3	1				
Tower element	GR6	6,0	T4	1	6,000	2,340	2,318	5 920
Tower element	GR6B	12,0	T5	1	12,000	2,550	2,320	15 620
Foundation legs GR6L		4			2,135	0,60	0,60	467 x 4
Foundation legs GR6		4			2,515	0,80	0,80	810 x 4
Foundation legs GR6B		4			2,525	0,80	0,80	960 x 4
Crossbase support		B1	4		0,900	900	400	352
Crossbase long beam		B2	1		11,915	875	980	3 415
Crossbase short beam		B3	2		5,780	745	980	1 625
Crossbase traverse		B4	2		7,440	275	347	288
Crossbase traverse		B5	2		7,440	174	347	468
Crossbase tower element		B6	1		5,990	2,300	2,300	5,428
Crossbase struts		B7	4		7,324	420	397	683
Crossbase access ladder		B8	1		1,275	60	45	10
Main ballast	ZB880	Z1	2		6,650	450	1,490	8 000
Ballast	ZB580	Z2	-		5,580	450	1,100	5 000

# LR330 18t



The Raimondi LR330 luffing jib crane may be equipped with two different hoisting winches: standard installed power of 80kW or the two falls configuration with the more powerful 110kW



## RAIMONDI® LR330

SINCE 1863

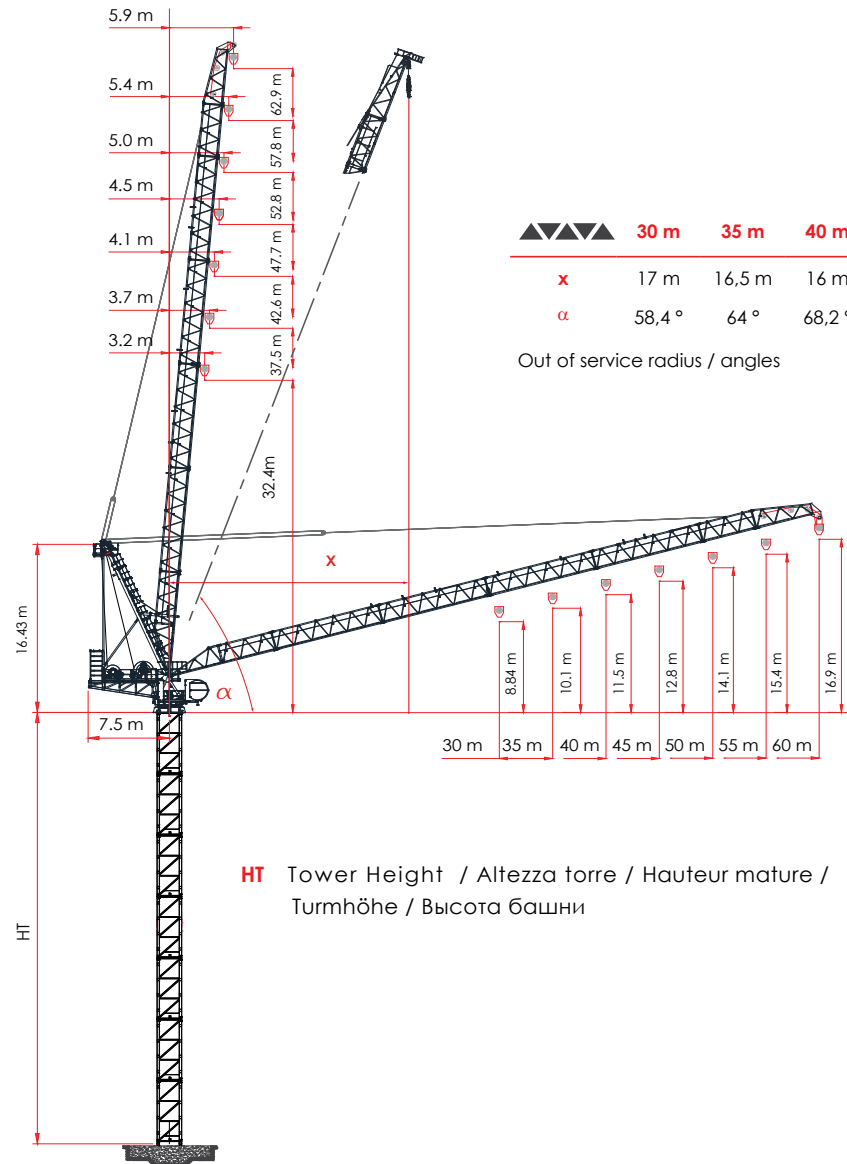

	30 m	35 m	40 m	45 m	50 m	55 m	60 m
x	17 m	16,5 m	16 m	17,5 m	19,6 m	20,5 m	21,5 m
α	58,4°	64°	68,2°	68,7°	68,6°	69,5°	70,3°





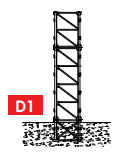
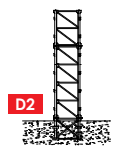
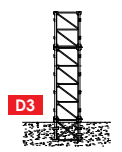
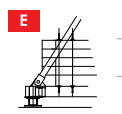











Out of service radius / angles

**HT** Tower Height / Altezza torre / Hauteur mature / Turmhöhe / Высота башни

-   GR6L  
HT 54,4 m C25  
Embedded element
-   GR6 / GR6L  
HT 63,4 m C25  
Embedded element
-   GR6B / GR6 / GR6L  
HT 72,4 m C25  
Booster  
Embedded element
-   GR6L  
HT 61,4 m C25  
Base 8x8 m

    
2000/14/CE  
EN 14439 C25 D25 - FEM 1.001



IT	EN	F	DE	RU
 Altezza sotto gancio	Height under hook	Hauteur sous crochet	Höhe unter dem Haken	Высота под крюком
 Contrappesi	Counter weight jib ballast	Lest de contre-flèche	Gegenauslegerballast	Противовесы
 Freccia	Jib	Flèche	Kranarm	стрела крана
 Carico massimo	Max load	Charge maximale	Maximale Belastung	максимальная нагрузка
 Curva di carico Ultralift	Load diagrams with ultralift control	Courbes de charges Ultralift	Lastkurven Ultralift	Кривой Груз Ultralift
 Altezza libera	Free Standing	Hauteur libre	Freistehend	Свободностоящая высота
 Azionamenti	Mechanisms	Mécanismes	Antriebe	Приводы
 Velocità	Speed	Vitesse	Geschwindigkeit	скорость
 5 marce con velocità proporzionale al carico	5 step with speed proportional to the load	5 rapports avec une vitesse proportionnelle à la charge	5 Gang Geschwindigkeit proportional zum Last	Автоматический выбор скорости механизма подъема в зависимости от величины груза
 Tiro a 2 funi	Two - rope pull	Tir à deux câbles	Zug an zwei Seilen	Двукратная запасовка тросов
 Tiro a 4 funi	Four - rope pull	Tir à quatre câbles	Zug an vier Seilen	Четырехкратная запасовка тросов
 Totale metri fune tamburo	Total meters rope drum	Total des mètres de corde du tambour	Total Meter Seil Trommel	Запас троса на барабане в метрах
 Diametro fune	Rope diameter	Diamètre du câble	Seildurchmesser	Диаметр троса
 Rotazione	Slewing	Orientation	Schwenken	Поворот
 Braccio impennabile	Luffing jib	Flèche rélevable	Arm mit erhöht	Стрела крана подъемный
 Traslazione	Travelling	Translation	Kranfahren	Перемещение крана

**STANDARD**



 2000 / 14 / CE

**18 t 150 hp 110 kW**

STEP



400 V ± 5% 50 Hz

		m/min	kg	m/min	kg
 900 m	1	24	9 000	12	18 000
 286 kVA	2	60	9 000	30	18 000
 Ø 24 mm	3	120	4 500	60	9 000
		↓	↓	↓	↓
	4	192	2 500	96	5 000
		↓	↓	↓	↓
	5	240	1 750	120	3 500

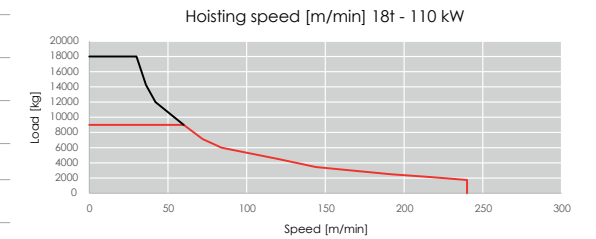

The speed at which loads are lifted or lowered is automatically regulated by the control system.

kVA **Power required** / Potenza richiesta / Puissance requise / Erforderliche Leistung / Потребляемая мощность



0 / 0,8 r.p.m. ▪ 2 x 15 kW /



14,5° / 85°

1,8 min ▪ 75 kW /



- m/min ▪ \_ x \_ kW

	Jib	30,0 m	35,0 m	40,0 m	45,0 m	50,0 m	55,0 m	60,0 m
LR330 - 9,0t UL	9 t ▶	30 m	35 m	40 m	42 m	40 m	38 m	37 m
	28	9000	9000	9000	9000	9000	9000	9000
	29	9000	9000	9000	9000	9000	9000	9000
	<b>30</b>	<b>9000</b>	9000	9000	9000	9000	9000	9000
	33		9000	9000	9000	9000	9000	9000
	<b>35</b>		<b>9000</b>	9000	9000	9000	9000	9000
	38			9000	9000	9000	9000	8724
	<b>40</b>			<b>9000</b>	9000	8903	8589	8021
	43				8944	7974	7644	7088
	<b>45</b>					<b>8250</b>	7420	6535
	48						6671	5790
	<b>50</b>						<b>6380</b>	5343
53							4734	
<b>55</b>							<b>4840</b>	4363
58								3853
<b>60</b>								<b>3520</b>
LR330 - 18,0t UL	18 t ▶	23 m	24 m	25 m	25 m	23 m	25 m	26 m
	23	18000	18000	18000	18000	18000	16000	14000
	24	17834	18000	18000	18000	17924	16000	14000
	25	16974	17853	18000	18000	17031	16000	14000
	26	16178	17005	17186	17956	16205	15346	14000
	28	14756	15493	15683	16325	14727	13909	13270
	29	14116	14817	15008	15595	14064	13263	12632
	<b>30</b>	<b>13517</b>	14186	14377	14914	13444	12660	12035
	33		12529	12711	13125	11807	11067	10461
	<b>35</b>		<b>11208</b>	11756	12104	10869	10155	9559
	38			10510	10778	9645	8964	8383
	<b>40</b>			<b>9680</b>	10005	8929	8268	7695
	43				8982	7978	7343	6782
	<b>45</b>					<b>8030</b>	7414	6239
	48						6653	5510
	<b>50</b>						<b>6160</b>	5071
	<b>55</b>							<b>4620</b>
<b>60</b>								<b>3300</b>

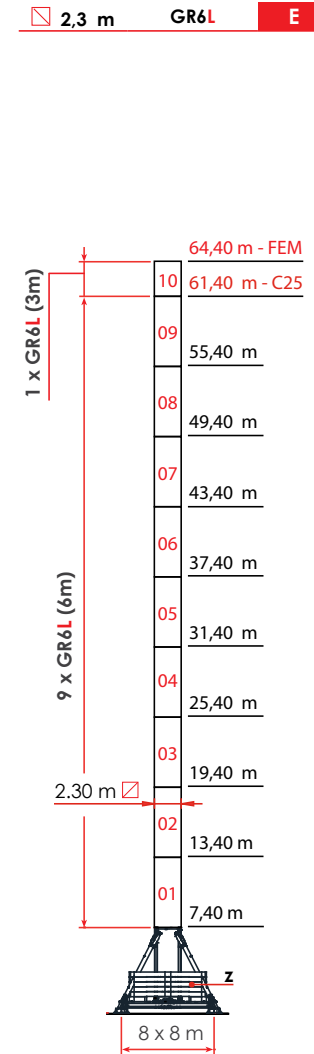

Base 8,0 x 8,0 m		FEM 1.001					
HT [m]	60m	55m	50m	45m	40m	35m	30m
	Z [t]						
64,4							196
61,4						196	186
58,4					196	176	156
55,4				186	176	156	136
52,4		176	166	146	136	116	106
49,4	176	156	146	126	116	96	86
43,4	136	116	96	86	76	66	56
37,4	96	86	56	46	46	46	46
31,4	66	56	46	46	46	46	46
25,4	46	46	46	46	46	46	46
19,4	46	46	46	46	46	46	46

Base 8,0 x 8,0 m		EN14439 C25					
HT [m]	60m	55m	50m	45m	40m	35m	30m
	Z [t]						
61,4							176
58,4						186	166
55,4					176	166	146
52,4		186	176	156	136	126	106
49,4	186	166	146	136	116	106	86
43,4	146	116	106	86	76	66	56
37,4	96	76	66	56	46	46	46
31,4	56	46	46	46	46	46	46
25,4	46	46	46	46	46	46	46
19,4	46	46	46	46	46	46	46

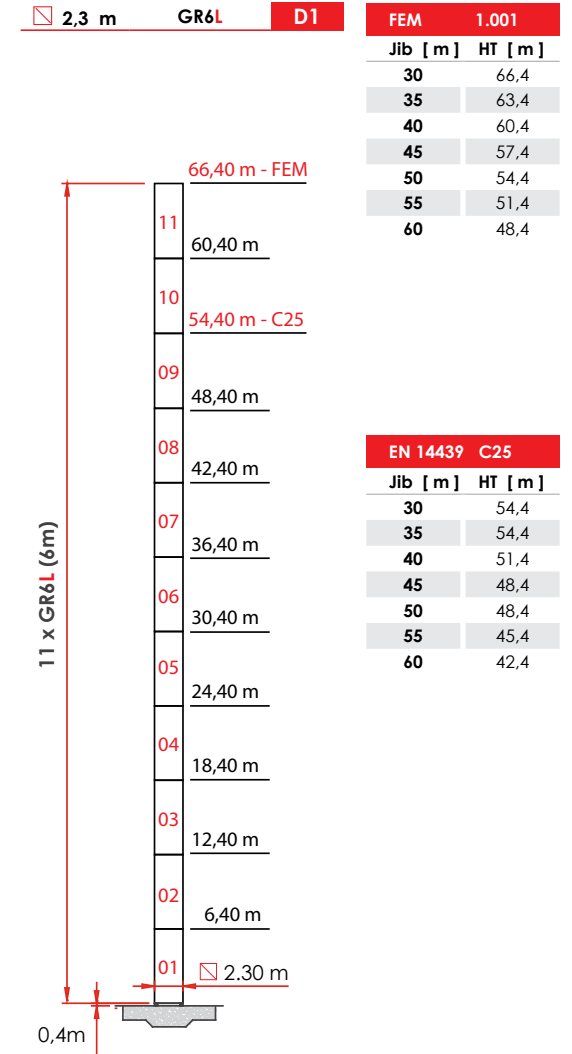

Base 8,0 x 8,0 m		D1		FEM 1.001	
Jib [m]	HT [m]	Jib [m]	HT [m]	Jib [m]	HT [m]
30	66,4	30	66,4	30	66,4
35	63,4	35	63,4	35	63,4
40	60,4	40	60,4	40	60,4
45	57,4	45	57,4	45	57,4
50	54,4	50	54,4	50	54,4
55	51,4	55	51,4	55	51,4
60	48,4	60	48,4	60	48,4

EN 14439 C25	
Jib [m]	HT [m]
30	54,4
35	54,4
40	51,4
45	48,4
50	48,4
55	45,4
60	42,4

**ULTRALIFT** If the crane is not equipped with Ultralift control, all intermediate loads are decreased by 10% / Senza il sistema Ultralift tutte le portate intermedie diminuiscono il carico del 10%

Jib	Jib length	HT (m)	Total tower height	A	Base on concrete pads
B	Travelling base	D	Crane on embedded	E	Base on steel pads

2,3 m GR6 / GR6L D2

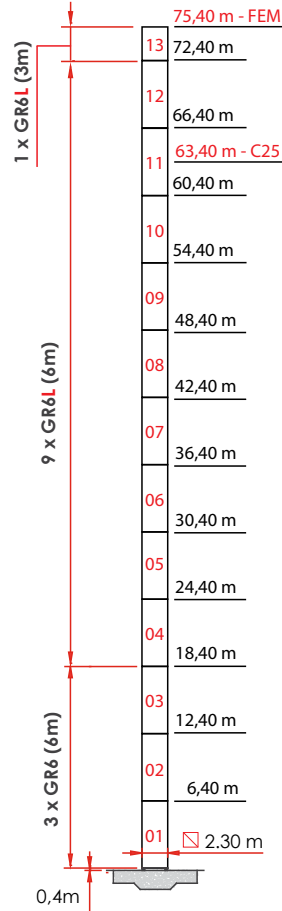

FEM 1.001

Jib [m]	HT [m]
30	75,4
35	72,4
40	72,4
45	69,4
50	66,4
55	63,4
60	60,4

EN 14439 C25

Jib [m]	HT [m]
30	63,4
35	63,4
40	60,4
45	57,4
50	57,4
55	54,4
60	51,4

2,3 m GR6B/GR6/GR6L D3

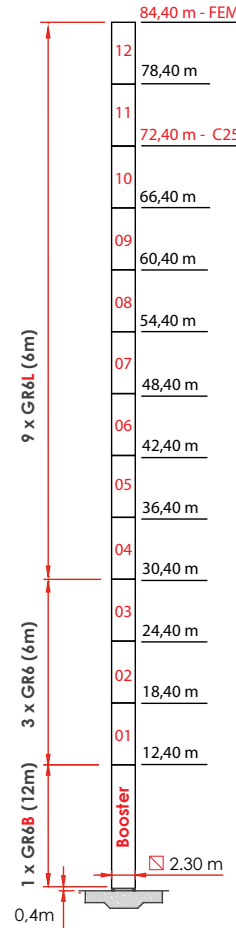

FEM 1.001

Jib [m]	HT [m]
30	84,4
35	81,4
40	78,4
45	78,4
50	75,4
55	75,4
60	72,4

EN 14439 C25

Jib [m]	HT [m]
30	72,4
35	72,4
40	69,4
45	66,4
50	66,4
55	63,4
60	60,4

Jib	Jib length	HT (m)	Total tower height	A	Base on concrete pads
B	Travelling base	D	Crane on embedded	E	Base on steel pads

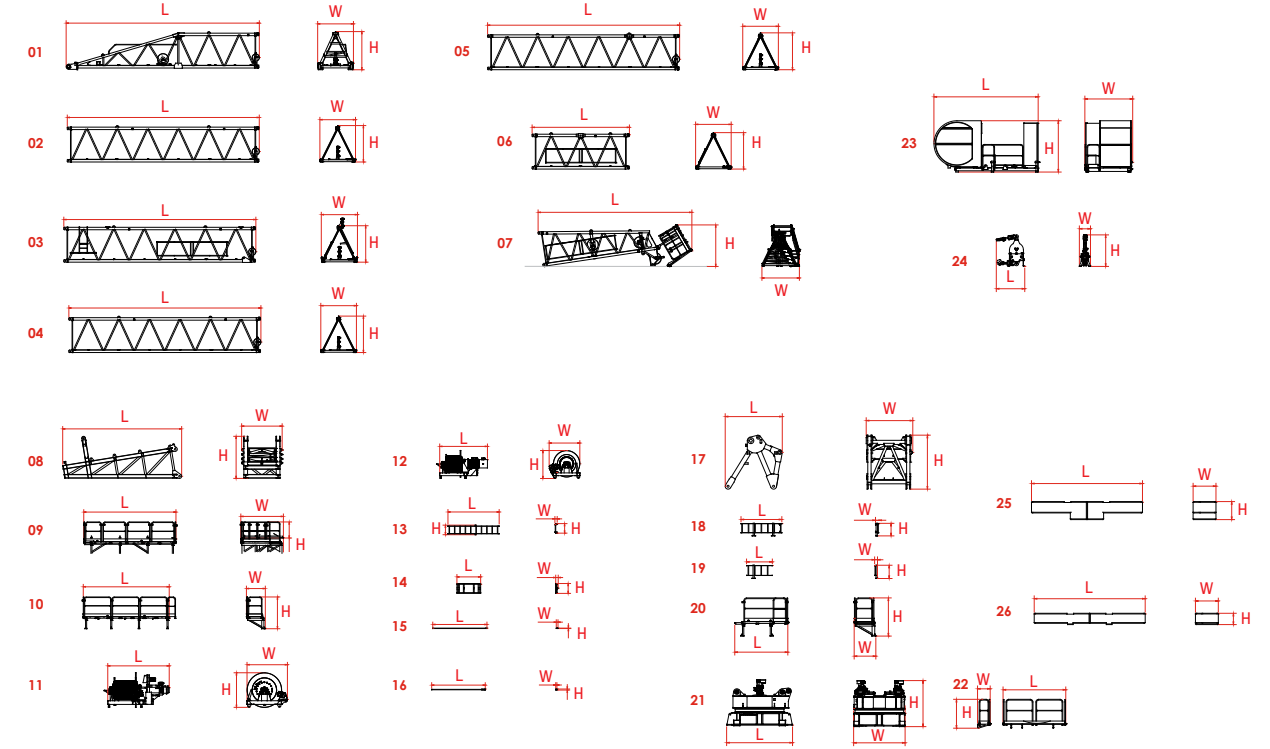

10 x 13,60 m

LR330\_Jib 60 m ▪  
 Top part / Parte rotante / Partie tournante / Drehender Kranteil / Поворотная часть

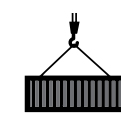

3 x 40 High cube

Included counter weight and cabin / Cabina e contrappesi inclusi / Cabine et contrepoids inclus / Kabine und Gegengewichts Blöcke –inbegriffen / Противовес включен - кабина

2 x 40 Open Top

6 x 40 Box

L (m)	Length of the element	H (m)	Height of the element
W (m)	Width of the element	Kg	Unit weight

## JIB AND COUNTER-JIB PACKING LIST

Jib and Counter-jib Elements			DIMENSIONS [ m ]			
UNIT	POS.	QUANTITY	L	W	H	Kg
Jib element*	01	1	10 443	1 933	2 061	2 822
Jib element	02	1	10 383	1 925	1 969	1 480
Jib element*	03	1	10 383	1 953	1 969	1 466
Jib element	04	1	10 383	1 925	1 969	1 369
Jib element	05	1	10 383	1 925	1 992	1 431
Jib element	06	1	5 260	1 925	1 969	845
Jib element	07	1	8 314	2 027	2 243	1 666
Counter-jib	08	1	6 433	2 190	2 273	4 045
Balcony (left side)	09	1	4 984	2 300	2 717	882
Balcony (right side)	10	1	4 684	1 022	1 717	308
Hoisting winch with rope (110 kW)	11	1	3 323	2 183	1 870	6 524
Luffing winch with rope (75 kW)	12	1	2 580	1 660	1 512	3 156
Counterweight access ladder	13	1	2 770	123	516	30
Counterweight fixing system	14	1	1 264	135	534	7
External tie Counterweight	15	1	2 930	94	24	11
internal tie Counterweight	16	1	2 895	65	54	12
A-Frame Support	17	1	2 570	2 100	2 430	3 141
External ladder (left side)	18	1	1 840	145	566	32
External ladder (right side)	19	1	1 160	130	596	18
A-Frame support balcony	20	1	2 390	975	1 717	148
Slewing unit	21	1	2 970	2 320	2 074	10 351
Slewing unit balcony	22	1	2 825	571	1 304	97
Balcony with Cabin and electrical cabin	23	1	4 696	2 155	2 310	2 067
Hook Block	24	1	1 281	500	1 422	675
Counter-weight 21510_01	25	1	5 000	1 030	810	6 600
Counter-weight 21510_02	26	5	5 000	1 030	510	5 200

\* With platform and accessories

## A-FRAME PACKING LIST

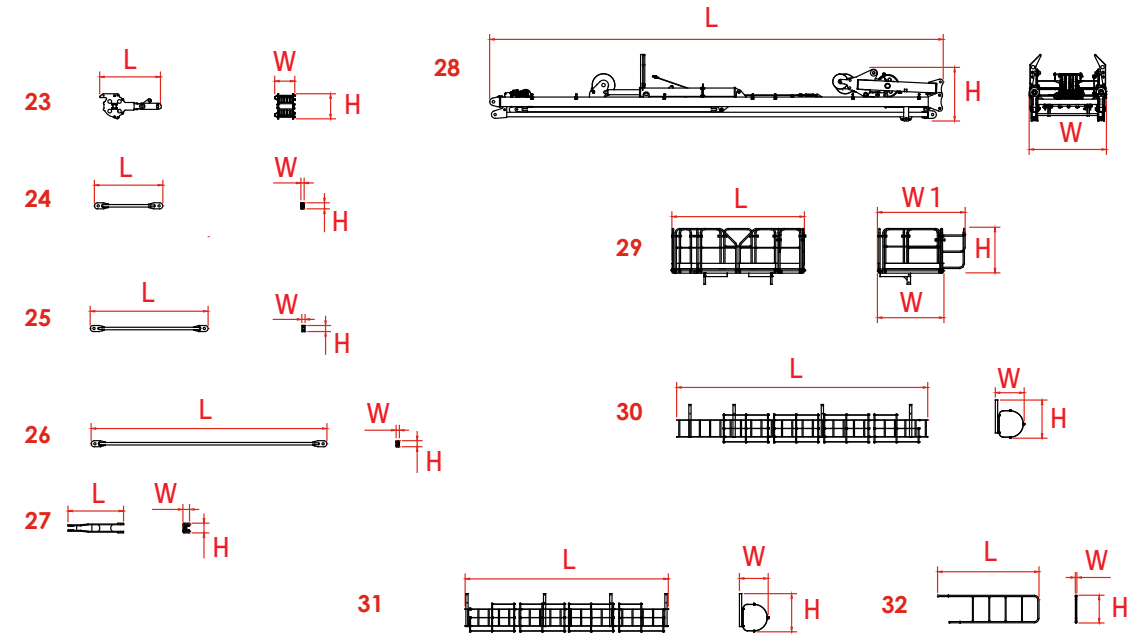

A-Frame Elements			DIMENSIONS [ m ]			UNIT WEIGHT
UNIT	POS.	QUANTITY	L	W	H	Kg
Mobile sheave block for luffing rope	23	1	1 597	660	528	296
Tie short	24	1	1 800	85	160	60
Tie medium	25	3	3 100	85	160	281
Tie long	26	4	6 200	85	160	697
Tie	27	1	1 460	175	255	96
Counter-jib A-frame unit	28	1	11 922	2 030	1 750	5 730
Balcony	29	1	3 485	1 750	1 467	350
Top Ladder	30	1	6 600	757	1 005	135
Bottom Ladder	31	1	5 340	757	1 005	120
Removable handrails	32	1	2 667	43	733	15



## TOWER AND BASE PACKING LIST

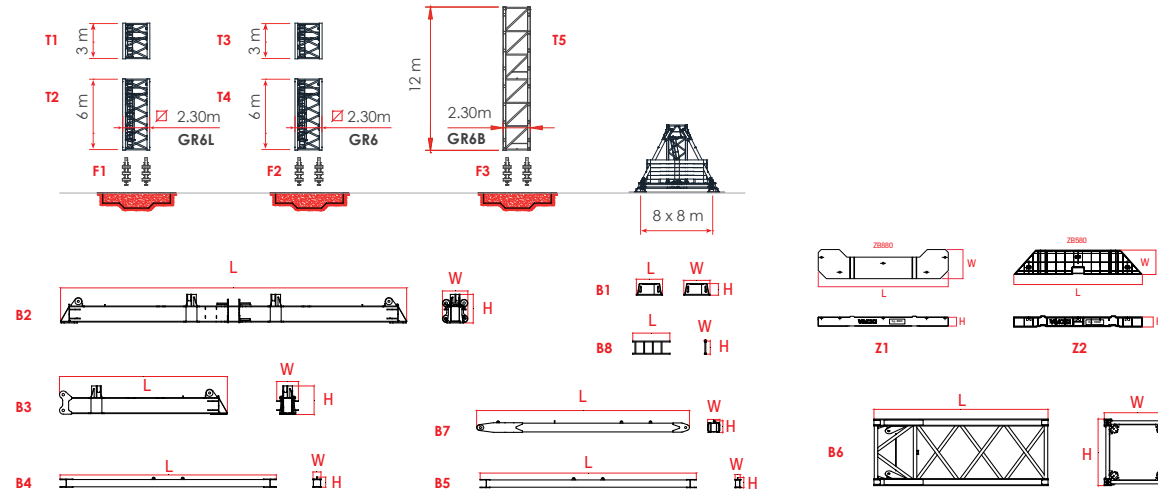

Tower 2.30 m and base package list

UNIT	POS.	QUANTITY	DIMENSIONS [ m ]			UNIT WEIGHT		
			L	W	H	Kg	H	Kg
Tower element	GR6L	3,0	T1	1	3,000	2,290	2,276	2 680
Tower element		6,0	T2	1	6,000	2,290	2,276	4 865
Tower element	GR6	3,0	T3	1				
Tower element		6,0	T4	1	6,000	2,340	2,318	5 920
Tower element	GR6B	12,0	T5	1	12,000	2,550	2,320	15 620
Foundation legs GR6L				4	2,135	0,60	0,60	467 x 4
Foundation legs GR6				4	2,515	0,80	0,80	810 x 4
Foundation legs GR6B				4	2,525	0,80	0,80	960 x 4
Crossbase support			B1	4	0,900	900	400	352
Crossbase long beam			B2	1	11,915	875	980	3 415
Crossbase short beam			B3	2	5,780	745	980	1 625
Crossbase traverse			B4	2	7,440	275	347	288
Crossbase traverse			B5	2	7,440	174	347	468
Crossbase tower element			B6	1	5,990	2,300	2,300	5,428
Crossbase struts			B7	4	7,324	420	397	683
Crossbase access ladder			B8	1	1,275	60	45	10
Main ballast	ZB880		Z1	2	6,650	450	1,490	8 000
Ballast	ZB580		Z2	-	5,580	450	1,100	5 000





The Raimondi LR330 luffing jib crane erected in Legnano, Milan, Italy





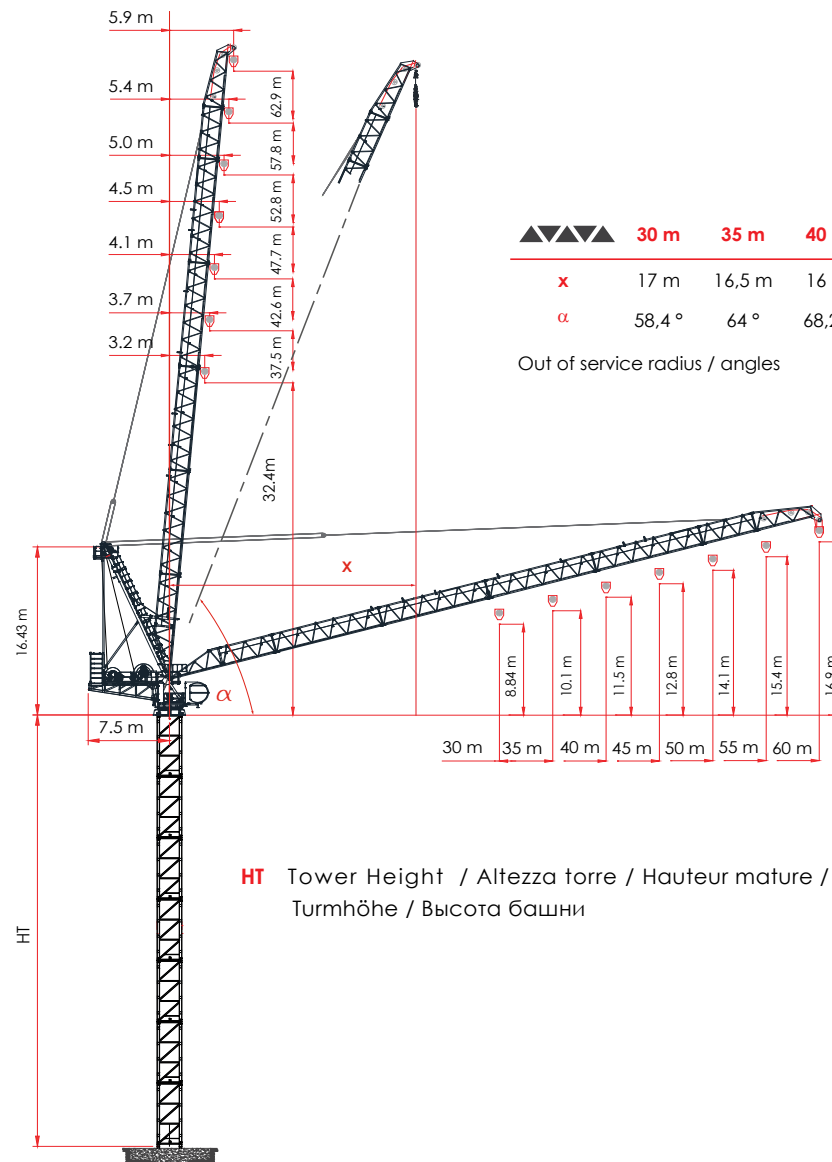

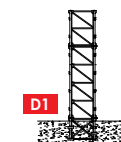

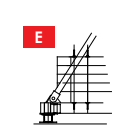











The Raimondi LR372's seven different jib length configurations, from 30 meters to 60 meters, satisfy all needs in terms of specific jobsite configurations



	<input checked="" type="checkbox"/> GR6L
	HT 54,4 m C25
	Embedded element
	<input checked="" type="checkbox"/> GR6 / GR6L
	HT 63,4 m C25
	Embedded element
	<input checked="" type="checkbox"/> GR6B / GR6 / GR6L
	HT 72,4 m C25
	Booster
	<input checked="" type="checkbox"/> GR6L
	HT 61,4 m C25
	Base 8x8 m

**HT** Tower Height / Altezza torre / Hauteur mature / Turmhöhe / Высота башни



IT	EN	F	DE	RU
 Altezza sotto gancio	Height under hook	Hauteur sous crochet	Höhe unter dem Haken	Высота под крюком
 Contrappesi	Counterjib ballast	Lest de contre-flèche	Gegenauslegerballast	Противовесы
 Freccia	Jib	Flèche	Ausleger	стрела
 Carico massimo	Max load	Charge maximale	Maximale Belastung	максимальная нагрузка
 Curva di carico Ultralift	Load diagram with ultralift control	Courbe de charges Ultralift	Lastkurven Ultralift	Кривой Груз Ultralift
 Altezza libera	Free Standing height	Hauteur libre	Freistehend	Свободностоящая высота
 Azionamenti	Mechanisms	Mécanismes	Antriebe	Приводы
 Velocità	Speed	Vitesse	Geschwindigkeit	скорость
 5 marce con velocità proporzionale al carico	5 step with speed proportional to the load	5 rapports avec une vitesse proportionnelle à la charge	5 Gang Geschwindigkeit proportional zum Last	Автоматический выбор скорости механизма подъема в зависимости от величины груза
 Tiro a 1 fune	One - rope pull	Tir à un cable	im1—fachen Seilstrangbetrieb	Однократная запасовка каната
 Tiro a 2 funi	Two - rope pull	Tir à deux cables	im2—fachen Seilstrangbetrieb	Двукратная запасовка тросов
 Capacità del tamburo	Drum capacity	Capacité du tambour	Fassungsvermögen der Trommel	Канатоемкость барабана
 Diametro fune	Rope diameter	Diamètre du cable	Seildurchmesser	Диаметр троса
 Rotazione	Slewing	Orientation	Schwenken	Поворот
 Braccio impennabile	Luffing jib	Flèche rélevable	Wippausleger	Стрела крана подъемный
 Traslazione	Travelling	Translation	Kranfahren	Перемещение крана

**STANDARD**

 2000 / 14 / CE

**20 t 150 hp 110 kW**

400 V ± 5% 50 Hz

		m/min	kg	m/min	kg
 880 m		5,4	10 000	2,7	20 000
		↓	↓	↓	↓
 286 kVA		54	10 000	27	20 000
		↓	↓	↓	↓
 Ø 24 mm		102	5 000	51	10 000
		↓	↓	↓	↓
		190	2 000	95	4 000
		↓	↓	↓	↓
		222	1 250	111	2 500
		↓	↓	↓	↓
		256	500	128	1 000

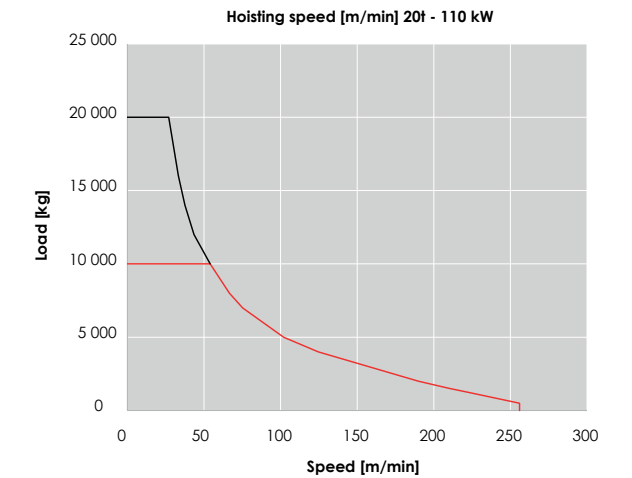

The speed at which loads are lifted or lowered is automatically regulated by the control system.

kVA **Power required** / Potenza richiesta / Puissance requise / Erforderliche Leistung / Потребляемая мощность

 0 / 0,8 r.p.m. ▪ 2 x 15 kW /  14,5° / 85° 2,1 min ▪ 75 kW

U <sub>Lift</sub>	Jib	30,0 m	35,0 m	40,0 m	45,0 m	50,0 m	55,0 m	60,0 m
	MAX LOAD ▶		30 m	35 m	40 m	40 m	38 m	37 m
	15	10000	10000	10000	10000	10000	10000	10000
	<b>30</b>	<b>10000</b>	10000	10000	10000	10000	10000	10000
	32		10000	10000	10000	10000	10000	10000
	34		10000	10000	10000	10000	10000	10000
	<b>35</b>		<b>10000</b>	10000	10000	10000	10000	10000
	37			10000	10000	10000	10000	9416
	39			10000	10000	9945	9260	8675
	<b>40</b>			<b>10000</b>	10000	9580	8911	8332
	42				9311	8902	8260	7694
	44				8674	8283	7667	7113
	<b>45</b>				<b>8370</b>	7992	7390	6842
	49					6934	6389	5863
	<b>50</b>					<b>6655</b>	6162	5642
	54						5325	4834
	<b>55</b>						<b>5115</b>	4649
	<b>60</b>							<b>3795</b>

U <sub>Lift</sub>	Jib	30,0 m	35,0 m	40,0 m	45,0 m	50,0 m	55,0 m	60,0 m
	MAX LOAD ▶		22 m	22 m	23 m	23 m	22 m	23 m
	15	20000	20000	20000	20000	20000	18000	15000
	<b>30</b>	<b>14585</b>	14580	14217	14207	14168	13328	12674
	32		13389	13067	13051	12986	12189	11555
	34		12327	12045	12025	11943	11184	10568
	<b>35</b>		<b>11660</b>	11575	11554	11465	10724	10116
	37			10703	10684	10586	9879	9286
	39			9903	9898	9796	9119	8541
	<b>40</b>			<b>9790</b>	9532	9430	8767	8195
	42				8846	8748	8113	7554
	44				8208	8126	7517	6969
	<b>45</b>				<b>8140</b>	7834	7238	6696
	49					6770	6231	5711
	<b>50</b>					<b>6490</b>	6003	5489
	54						5161	4676
	<b>55</b>						<b>4950</b>	4489
	<b>60</b>							<b>3630</b>

**ULTRALIFT** If the crane is not equipped with Ultralift control, all intermediate loads are decreased by 10% / Senza il sistema Ultralift tutte le portate intermedie diminuiscono il carico del 10%

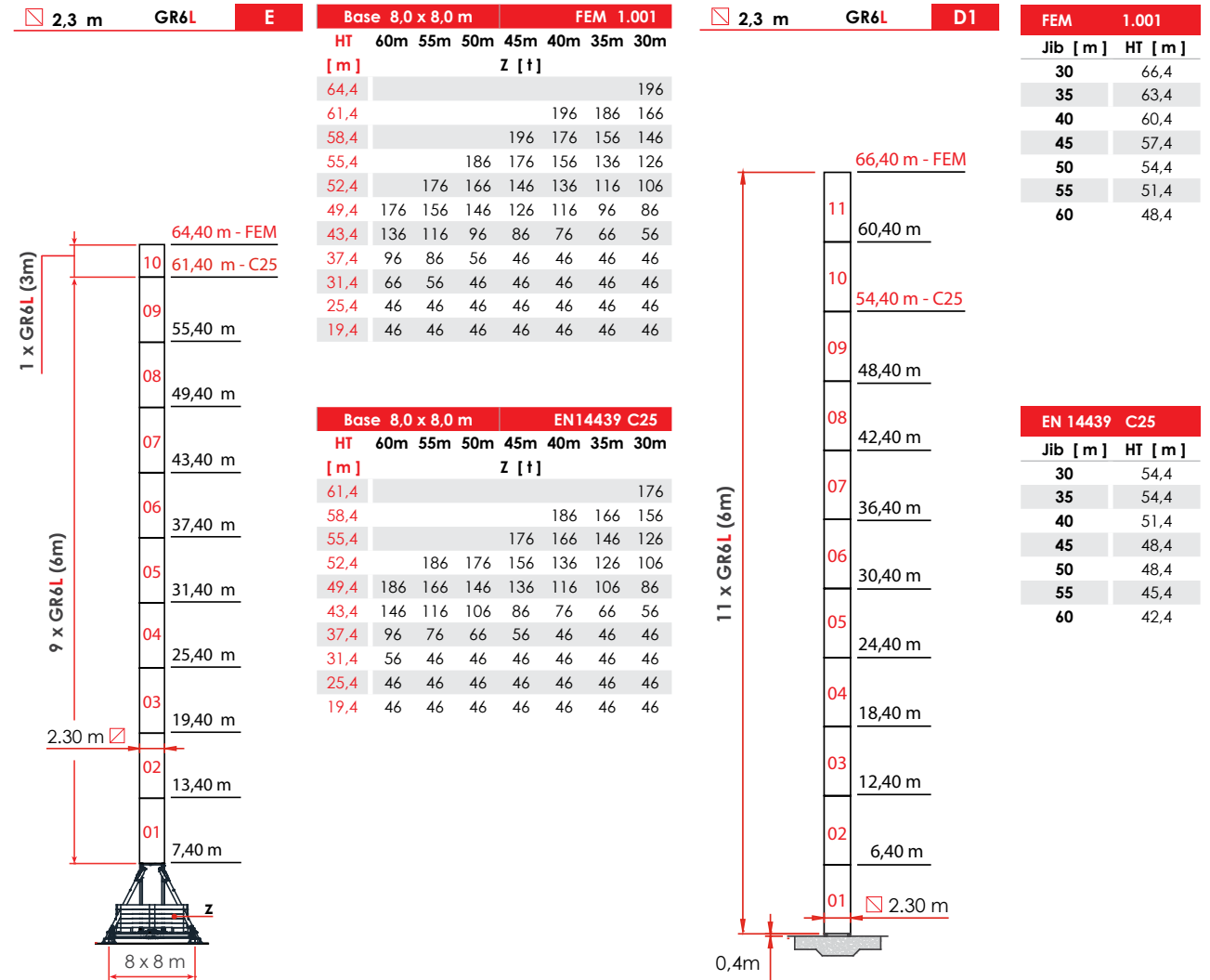

Jib	Jib length	HT (m)	Total tower height	A	Base on concrete pads
B	Travelling base	D	Crane on embedded	E	Base on steel pads

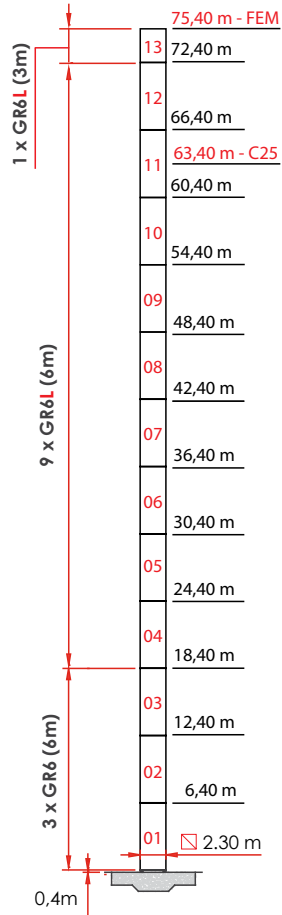

**2,3 m GR6 / GR6L D2**

**FEM 1.001**

Jib [m]	HT [m]
30	75,4
35	72,4
40	72,4
45	69,4
50	66,4
55	63,4
60	60,4

**EN 14439 C25**

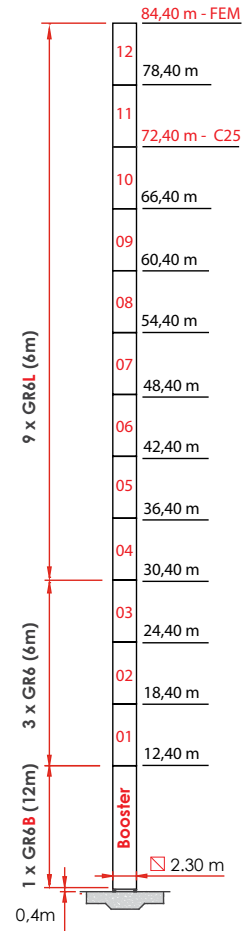
Jib [m]	HT [m]
30	63,4
35	63,4
40	60,4
45	57,4
50	57,4
55	54,4
60	51,4

**2,3 m GR6B/GR6/GR6L D3**

**FEM 1.001**

Jib [m]	HT [m]
30	84,4
35	81,4
40	78,4
45	78,4
50	75,4
55	75,4
60	72,4

**EN 14439 C25**

Jib [m]	HT [m]
30	72,4
35	72,4
40	69,4
45	66,4
50	66,4
55	63,4
60	60,4

Jib	Jib length	HT (m)	Total tower height	A	Base on concrete pads
B	Travelling base	D	Crane on embedded	E	Base on steel pads



10 x 13,60 m

LR372 \_Jib 60 m •

Top part / Parte rotante / Partie tournante / Drehender Kranteil / Поворотная часть

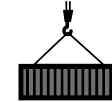

3 x 40 High cube

Included counter weight and cabin / Cabina e contrappesi inclusi / Cabine et contrepoids inclus / Kabine und Gegengewichts Blöcke – inbegriffen / Противовес включен - кабина

2 x 40 Open Top

6 x 40 Box

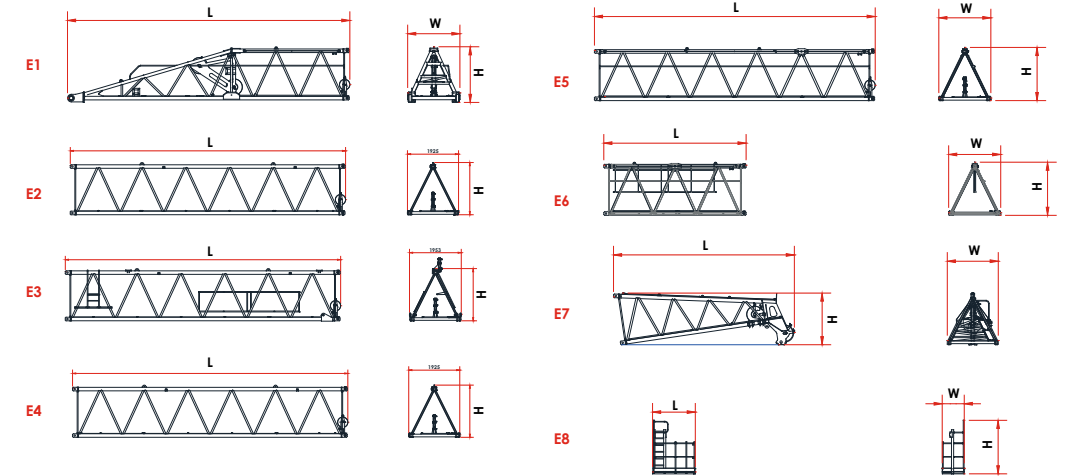

LR 372 - Jib Elements

UNIT	POS.	QUANTITY	DIMENSIONS [ m ]			UNIT WEIGHT
			L	W	H	Kg
Jib element*	E1	1	10443	1933	2061	3 053
Jib element*	E2	1	10383	1925	1969	1 480
Jib element*	E3	1	10383	1953	1969	1 466
Jib element*	E4	1	10383	1925	1969	1 369
Jib element*	E5	1	10383	1925	1969	1 500
Jib element*	E6	1	5260	1925	1969	910
Jib element*	E7	1	6700	1890	1920	1 410
Tip service balcony*	E8	1	1580	820	1980	150

\* With walkways and accessories

L (m)	Length of the element	H (m)	Height of the element	W (m)	Width of the element	Kg	Unit weight
-------	-----------------------	-------	-----------------------	-------	----------------------	----	-------------

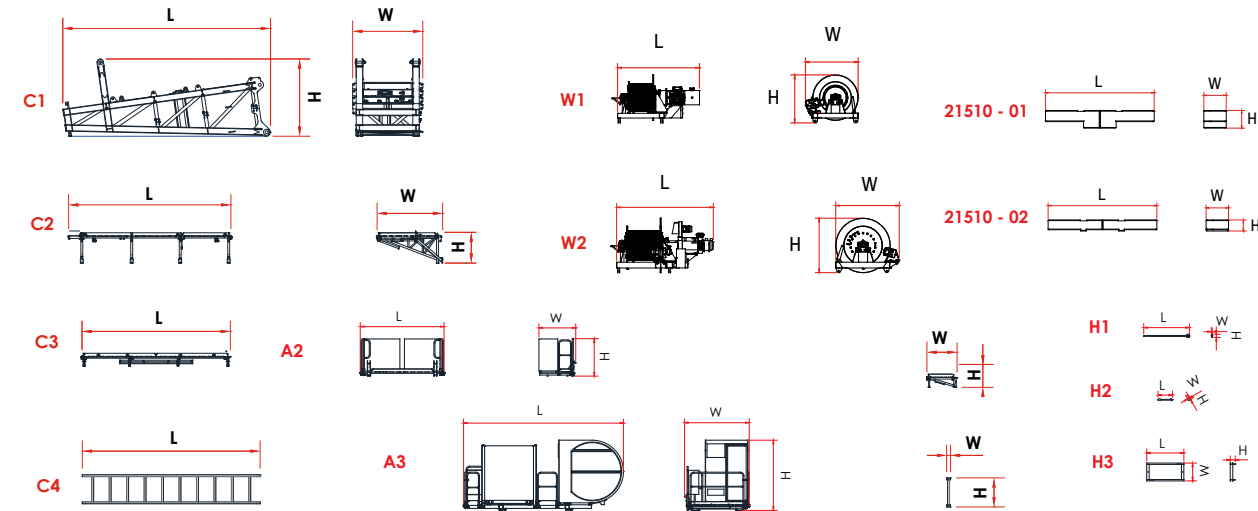

Counter-jib Elements DIMENSIONS [ m ] UNIT WEIGHT

UNIT	POS.	QUANTITY	L	W	H	Kg	
Counter-jib	C1	1	6450	2170	2400	4 450	
Balcony (CAB side)	C2	1	5020	2050	940	560	
Balcony (opposite CAB)	C3	1	4590	930	407	260	
Counterweight access ladder	C4	2	2750	60	450	10	
Luffing winch with rope (75 kW)	W1	1	2608	1600	1296	2 880	
Hoisting winch with rope (110 kW)	W2	1	3434	2009	1657	5 062 + F	
Base ballast block tie rods	H1	2	1 515	32	102	5	
Ballast fixing extensions	H2	8	475	42	36	2	
Ballast fixing frame	H3	1	1 230	590	164	40	
Resistance platform	A2	1	2780	1225	1245	385	
Cabin platform	A3	1	5300	2146	2325	1 990	
Counter-weight	21510_01	25	1	5 000	1 030	810	6 600
Counter-weight	21510_02	26	5	5 000	1 030	510	5 200

L (m)	Length of the element	H (m)	Height of the element	W (m)	Width of the element	Kg	Unit weight
-------	-----------------------	-------	-----------------------	-------	----------------------	----	-------------

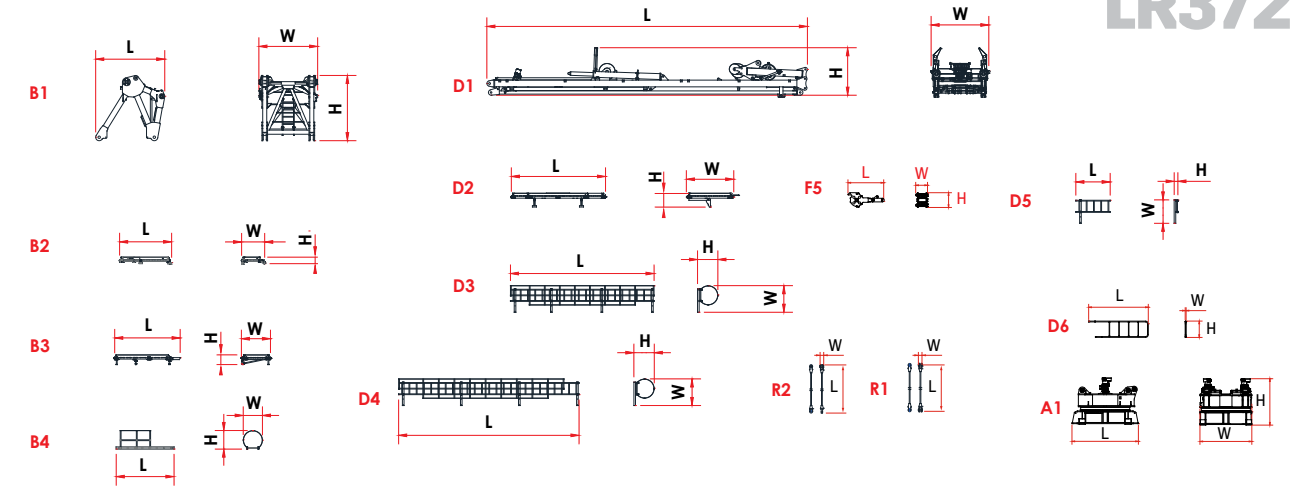

Upper part elements

UNIT	POS.	QUANTITY	DIMENSIONS [ m ]			UNIT WEIGHT
			L	W	H	Kg
Slewing unit GR6L - GR5H	A1 A	1	2970	2320	2074	10 590
Slewing unit GR6L	A1 B	1	2970	2320	2074	10 230
A-Frame Support	B1	1	2570	2185	2430	3 157
Balcony (opposite CAB)	B2	1	1935	859	275	98
Balcony (CAB side)	B3	1	2435	1081	360	122
Ladder A3/B4	B4	1	2150	720	690	8
Cusp	D1	1	11925	2150	1770	6 460
Cusp balcony	D2	1	3505	1765	513	315
Upper ladder	D3	1	5340	990	760	59
Intermediate ladder	D4	1	6710	990	760	65
Lower ladder	D5	1	1275	870	140	12
Handrail	D6	1	2667	43	733	15
Tie - rod Connection	F1	1	1460	245	171	69
Long tie - rod - L=6000	F2	4	6200	96	160	177
Long tie - rod - L=2900	F3	3	3100	96	160	97
Long tie - rod - L=1600	F4	1	1800	96	160	63
Mobile sheave block for luffing rope	F5	1	1620	542	660	316
Auxiliary rope type A F/F	R1	2	9200	Ø30		57
Auxiliary rope type B M/F	R2	6	9200	Ø30		53

L (m)	Length of the element	H (m)	Height of the element	W (m)	Width of the element	Kg	Unit weight
-------	-----------------------	-------	-----------------------	-------	----------------------	----	-------------



## TOWER AND BASE PACKING LIST

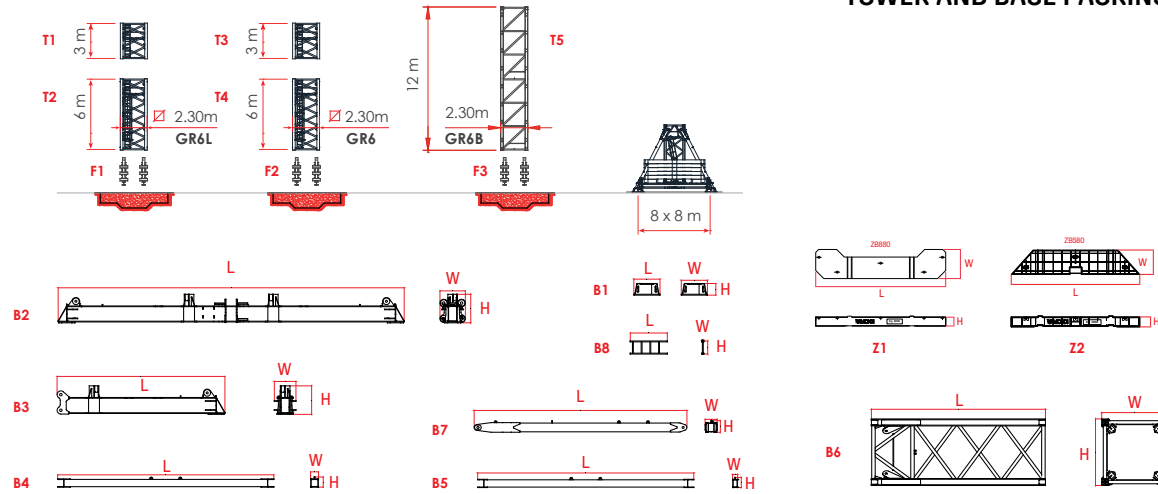

Tower 2,30 m and base package list

UNIT	m	POS.	QUANTITY	DIMENSIONS [ m ]			UNIT WEIGHT
				L	W	H	Kg
Tower element	3,0	T1	1	3,000	2,290	2,276	2 680
Tower element	6,0	T2	1	6,000	2,290	2,276	4 865
Tower element	3,0	T3	1				
Tower element	6,0	T4	1	6,000	2,340	2,318	5 920
Tower element	12,0	T5	1	12,000	2,550	2,320	15 620
Foundation legs GR6L		F1	4	2,135	0,60	0,60	467 x 4
Foundation legs GR6		F2	4	2,515	0,80	0,80	810 x 4
Foundation legs GR6B		F3	4	2,525	0,80	0,80	960 x 4
Crossbase support		B1	4	0,900	900	400	352
Crossbase long beam		B2	1	11,915	875	980	3 415
Crossbase short beam		B3	2	5,780	745	980	1 625
Crossbase		B4	2	7,440	275	347	288
Crossbase		B5	2	7,440	174	347	468
Crossbase tower element		B6	1	5,990	2,300	2,300	5,428
Crossbase struts		B7	4	7,324	420	397	683
Crossbase access ladder		B8	1	1,275	60	45	10
Main ballast ZB880		Z1	2	6,650	450	1,490	8 000
Ballast ZB580		Z2	-	5,580	450	1,100	5 000

L (m)	Length of the element	H (m)	Height of the element	W (m)	Width of the element	Kg	Unit weight
-------	-----------------------	-------	-----------------------	-------	----------------------	----	-------------

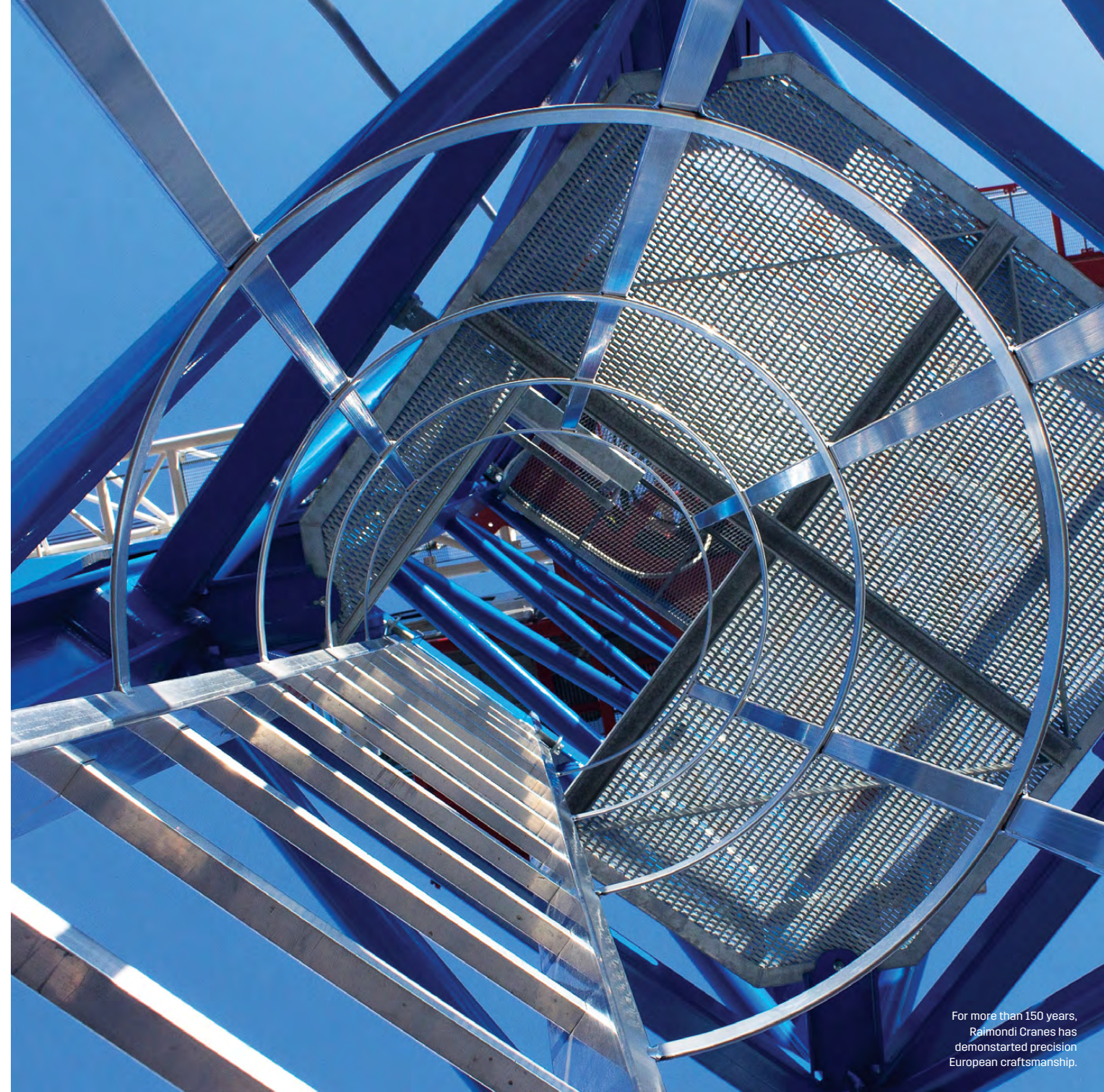



The LRH174 hydraulic luffing crane erected in Legnano, Milan, Italy, equipped with the Deluxe R16 Crane Cabin HT 35.7



**RAIMONDI**® LRH174  
SINCE 1863

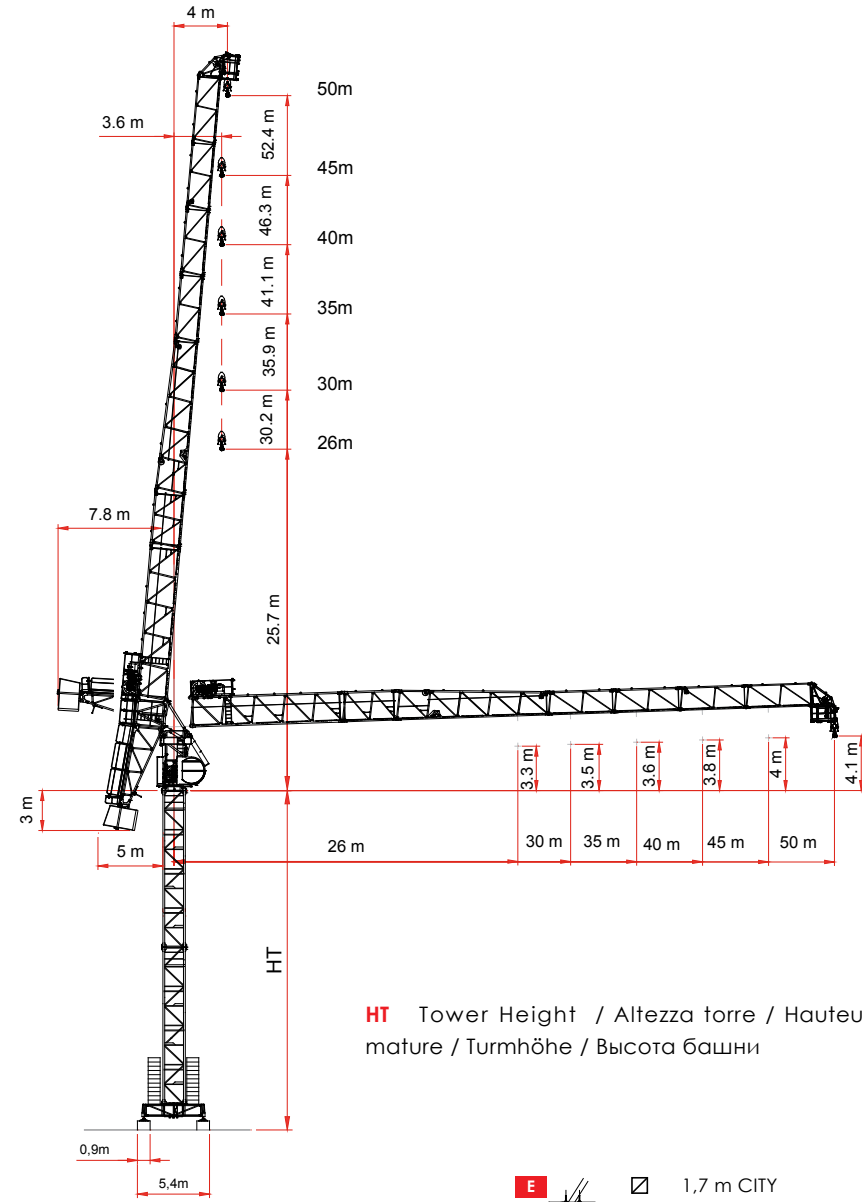

**HT** Tower Height / Altezza torre / Hauteur mature / Turmhöhe / Высота башни







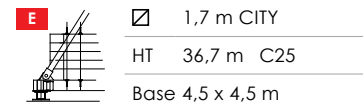
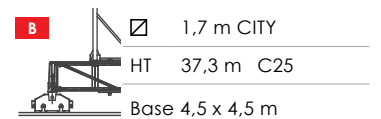
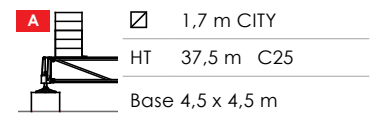
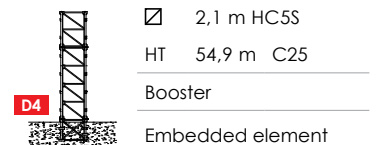
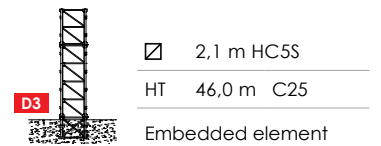
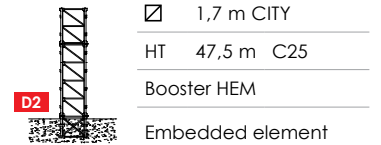
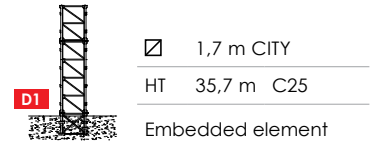











A4 EN 14439 c25

**LRH174**  
**10t**















IT	EN	F	DE	RU
 Altezza sotto gancio	Height under hook	Hauteur sous crochet	Höhe unter dem Haken	Высота под крюком
 Contrappesi	Counter weight jib ballast	Lest de contre-flèche	Gegenauslegerballast	Противовесы
 Freccia	Jib	Flèche	Kranarm	стрела крана
 Carico massimo	Max load	Charge maximale	Maximale Belastung	максимальная нагрузка
 Curva di carico Ultralift	Load diagrams with ultralift control	Courbes de charges Ultralift	Lastkurven Ultralift	Кривой Груз Ultralift
 Altezza libera	Free Standing	Hauteur libre	Freistehend	Свободностоящая высота
 Azionamenti	Mechanisms	Mécanismes	Antriebe	Приводы
 Velocità	Speed	Vitesse	Geschwindigkeit	скорость
 5 marce con velocità proporzionale al carico	5 step with speed proportional to the load	5 rapports avec une vitesse proportionnelle à la charge	5 Gang Geschwindigkeit proportional zum Last	Автоматический выбор скорости механизма подъема в зависимости от величины груза
 Tiro a 2 funi	Two - rope pull	Tir à deux câbles	Zug an zwei Seilen	Двукратная запасовка тросов
 Tiro a 4 funi	Four - rope pull	Tir à quatre câbles	Zug an vier Seilen	Четырехкратная запасовка тросов
 Totale metri fune tamburo	Total meters rope drum	Total des mètres de corde du tambour	Total Meter Seil Trommel	Запас троса на барабане в метрах
 Diametro fune	Rope diameter	Diamètre du câble	Seildurchmesser	Диаметр троса
 Rotazione	Slewing	Orientation	Schwenken	Поворот
 Braccio impennabile	Luffing jib	Flèche rélevable	Arm mit erhöht	Стрела крана подъемный
 Traslazione	Travelling	Translation	Kranfahren	Перемещение крана

kg	m	10,0 t	26,0	30,0	35,0	40,0	45,0	50,0
20 400	50	*	5000	5000	4069	3336	2757	<b>2255</b>
20 400	45	19,0	6967	5821	4745	3926	<b>3245</b>	
20 400	40	20,0	7427	6221	5085	<b>4180</b>		
20 400	35	20,0	7583	6363	<b>5170</b>			
17 000	30	20,5	7710	<b>6435</b>				
17 000	26	21,0	<b>7865</b>					

	26,0 m	30,0 m	35,0 m	40,0 m	45,0 m	50,0 m
x	11,0 m	11,0 m	10,0 m	10,0 m	10,0 m	10,0 m
α	26 °	22,4 °	17,5 °	15,3 °	13,8 °	12,2 °

Out of service radius / angles



 For different configuration contact the technical department / Per configurazioni diverse contattare l'ufficio tecnico / Pour des configurations différentes contact le département technique.

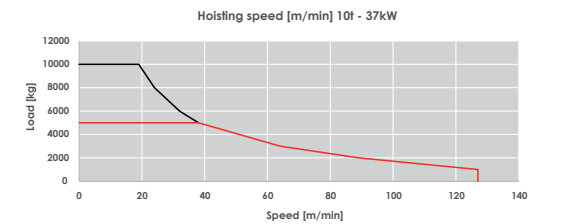
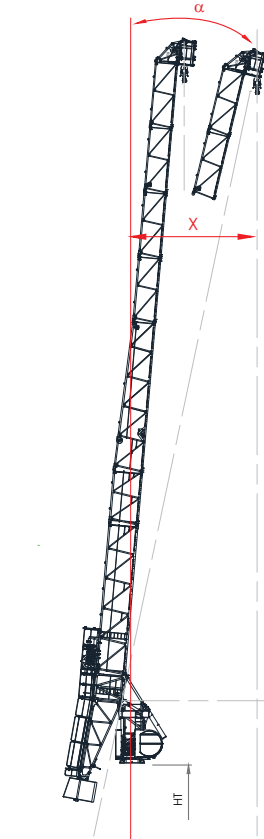

400 V ± 5% 50 Hz						2000 / 14 / CE	
10 t	50 hp	37 kW	STEP				
				m/min	kg	m/min	kg
 480 m			1	13	5 000	6,5	10 000
 180 kVA			2	38	5 000	19	10 000
 Ø 16 mm			3	64	3 000	32	6 000
				↓	↓	↓	↓
			4	89	2 000	44,5	4 000
				↓	↓	↓	↓
			5	127	1 000	63,5	2 000





The speed at which loads are lifted or lowered is automatically regulated by the control system.

kVA Power required / Potenza richiesta / Puissance requise / Erforderliche Leistung / Потребляемая мощность

 0 / 0,75 r.p.m. ▪ 2 x 4 kW /  2° / 85° 1,8 min ▪ 22 kW /  19 m/min ▪ 2 x 2,9 kW

		Freccia	26,0 m	30,0 m	35,0 m	40,0 m	45,0 m	50,0 m
LRH174 - 5,0t UL	 Tip load 5t ▶		3,5-26	3,5-30	3,5-35	3,5-36,5	3,6-34,5	3,65-31
	17,5	5000	5000	5000	5000	5000	5000	5000
	18	5000	5000	5000	5000	5000	5000	5000
	18,5	5000	5000	5000	5000	5000	5000	5000
	19	5000	5000	5000	5000	5000	5000	5000
	19,5	5000	5000	5000	5000	5000	5000	5000
	20	5000	5000	5000	5000	5000	5000	5000
	22,5	5000	5000	5000	5000	5000	5000	5000
	25	<b>5000</b>	5000	5000	5000	5000	5000	5000
	<b>26</b>	<b>5000</b>	5000	5000	5000	5000	5000	5000
	27,5		5000	5000	5000	5000	5000	5000
	<b>30</b>		<b>5000</b>	5000	5000	5000	5000	5000
	32,5			5000	5000	5000	4704	
	<b>35</b>				<b>5000</b>	5000	4948	4263
	37,5					4838	4518	3879
	<b>40</b>					<b>4400</b>	4139	3541
	42,5						3799	3240
	<b>45</b>						<b>3465</b>	2970
	47,5							2724
	<b>50</b>							<b>2475</b>

**ULTRALIFT** If the crane is not equipped with Ultralift control, all intermediate loads are decreased by 10% / Senza il sistema Ultralift tutte le portate intermedie diminuiscono il carico del 10%

		Freccia	26,0 m	30,0 m	35,0 m	40,0 m	45,0 m	50,0 m
LRH174 - 10,0t UL	 Tip load 10t ▶		3,4-21	3,5-20,5	3,5-20	3,5-20	3,5-19	3,65-30
	17,5	10000	10000	10000	10000	10000	10000	5000
	18	10000	10000	10000	10000	10000	10000	5000
	18,5	10000	10000	10000	10000	10000	10000	5000
	19	10000	10000	10000	10000	10000	10000	5000
	19,5	10000	10000	10000	10000	10000	9784	5000
	20	10000	10000	10000	10000	10000	9505	5000
	22,5	9335	9124	8986	8818	8289	5000	
	25	8271	8076	7945	7786	7308	5000	
	<b>26</b>	<b>7865</b>	7710	7583	7427	6967	5000	
	27,5		7206	7086	6935	6499	5000	
	<b>30</b>			<b>6435</b>	6363	6221	5821	5000
	32,5			5743	5612	5244	4516	
	<b>35</b>				<b>5170</b>	5085	4745	4069
	37,5					4622	4310	3679
	<b>40</b>					<b>4180</b>	3926	3336
	42,5						3582	3031
	<b>45</b>						<b>3245</b>	2757
	47,5							2507
	<b>50</b>							<b>2255</b>

**ULTRALIFT** If the crane is not equipped with Ultralift control, all intermediate loads are decreased by 10% / Senza il sistema Ultralift tutte le portate intermedie diminuiscono il carico del 10%

400 V ± 5% 50 Hz



2000 / 14 / CE

10 t 60 hp 45 kW		STEP				
			m/min	kg	m/min	kg
600 m	1		14	5 000	7	10 000
200 kVA	2		29	5 000	14,5	10 000
Ø 16 mm	3		57	5 000	28,5	10 000
	4		114	2 000	57	4 000
	5		190	500	95	1000

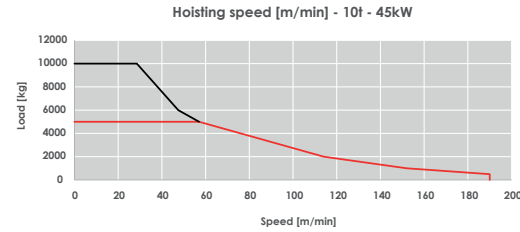

Il raggiungimento della velocità è regolato automaticamente dal sistema di controllo.  
The speed at which loads are lifted or lowered is automatically regulated by the control system.

kVA Power required / Potenza richiesta / Puissance requise / Erforderliche Leistung / Потребляемая мощность



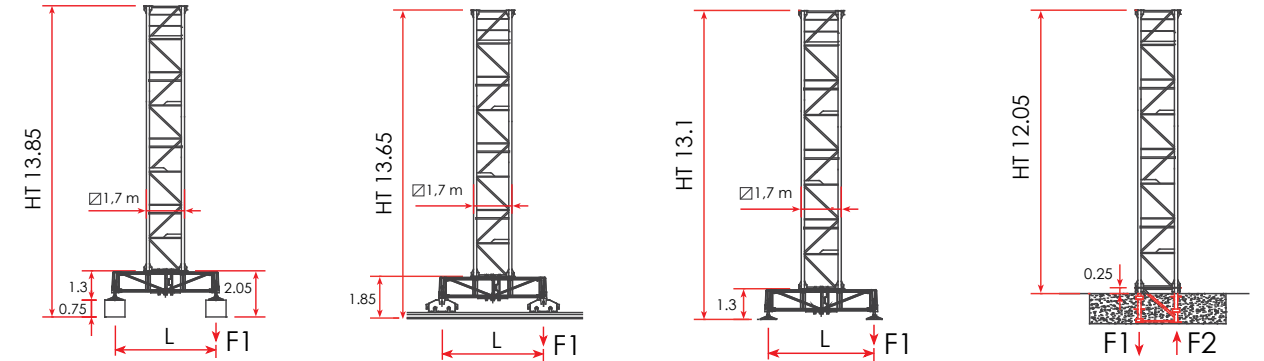









0 / 0,75 r.p.m. • 2 x 4 kW / 2° / 85° 1,8 min • 22 kW / 19 m/min • 2 x 2,9 kW















**A** C 1,7 m CITY Base on concrete pads - L 4,5 x 4,5 m - C EN14439 C25













EI	HT (m)	<span style="border: 1px solid black; padding: 0 2px;">C</span>	Δ (m)	Jib 50 m		Jib 45 m		Jib 40 m		Jib 35 m		Jib 30 m		Jib 26 m	
				Z (t)	F1↓ (kN)	Z (t)	F1↓ (kN)	Z (t)	F1↓ (kN)	Z (t)	F1↓ (kN)	Z (t)	F1↓ (kN)	Z (t)	F1↓ (kN)
+ 8	37,45	<span style="border: 1px solid black; padding: 0 2px;">C</span>	2,95											81,6	999
+ 7	34,50	<span style="border: 1px solid black; padding: 0 2px;">C</span>	2,95							91,8	1055	81,6	957	81,6	919
+ 6	31,55	<span style="border: 1px solid black; padding: 0 2px;">C</span>	2,95					81,6	1002	81,6	967	71,4	875	71,4	841
+ 5	28,60	<span style="border: 1px solid black; padding: 0 2px;">C</span>	2,95			81,6	978	81,6	921	81,6	889	71,4	802	61,2	768
+ 4	25,65	<span style="border: 1px solid black; padding: 0 2px;">C</span>	2,95	81,6	931	81,6	898	81,6	846	81,6	817	71,4	734	61,2	704
+ 3	22,70	<span style="border: 1px solid black; padding: 0 2px;">C</span>	2,95	71,4	846	71,4	819	71,4	772	71,4	751	61,2	669	61,2	655
+ 2	19,75	<span style="border: 1px solid black; padding: 0 2px;">C</span>	2,95	71,4	774	71,4	749	71,4	725	71,4	713	61,2	637	51,0	598
+ 1	16,80	<span style="border: 1px solid black; padding: 0 2px;">C</span>	2,95	71,4	725	71,4	713	71,4	695	71,4	684	61,2	608	51,0	574
-	13,85	<span style="border: 1px solid black; padding: 0 2px;">C</span>	2,95	71,4	690	71,4	679	71,4	664	71,4	653	61,2	582	51,0	548











<b>EI (n.)</b>	Number of tower elements	<b>Z (t)</b>	Total Ballast
<b>HT (m)</b>	Total tower height	<b>F1↓</b>	Maximum compression
<b>Δ (m)</b>	Element height	<b>F2↑</b>	Maximum traction

<b>B</b>		 1,7 m CITY		Travelling base - L 4,5 x 4,5 m -  EN14439 C25											
EI	HT		Δ	Jib 50 m		Jib 45 m		Jib 40 m		Jib 35 m		Jib 30 m		Jib 26 m	
n.	(m)		(m)	Z (t)	F1↓(kN)	Z (t)	F1↓(kN)	Z (t)	F1↓(kN)	Z (t)	F1↓(kN)	Z (t)	F1↓(kN)	Z (t)	F1↓(kN)
+ 8	37,25		2,95											102,0	1005
+ 7	34,30		2,95					112,2	1064	102,0	972	102,0	925		
+ 6	31,35		2,95					112,2	1015	102,0	975	91,8	888	91,8	846
+ 5	28,40		2,95			102,0	986	102,0	929	102,0	897	91,8	815	91,8	777
+ 4	25,45		2,95	102,0	927	102,0	906	102,0	854	102,0	824	91,8	746	81,6	708
+ 3	22,50		2,95	91,8	843	91,8	826	91,8	779	91,8	758	81,6	678	81,6	659
+ 2	19,55		2,95	91,8	771	91,8	756	91,8	731	91,8	719	81,6	645	81,6	630
+ 1	16,60		2,95	91,8	727	91,8	719	91,8	701	91,8	690	81,6	616	81,6	605
-	13,65		2,95	91,8	692	91,8	685	91,8	670	91,8	659	81,6	588	81,6	579

<b>D1</b>		 1,7 m CITY		Crane on embedded element -  EN14439 C25											
EI	HT		Δ	Jib 50 m		Jib 45 m		Jib 40 m		Jib 35 m		Jib 30 m		Jib 26 m	
n.	(m)		(m)	F1↓(kN)	F2↑(kN)	F1↓(kN)	F2↑(kN)	F1↓(kN)	F2↑(kN)	F1↓(kN)	F2↑(kN)	F1↓(kN)	F2↑(kN)	F1↓(kN)	F2↑(kN)
+ 8	35,65		2,95											1478	1222
+ 7	32,70		2,95							1457	1185	1310	1060	1363	1114
+ 6	29,75		2,95							1381	1109	1342	1077	1202	959
+ 5	26,80		2,95			1336	1069	1269	1005	1235	976	1102	866	1155	920
+ 4	23,85		2,95	1364	1095	1234	972	1165	905	1144	890	1018	787	1063	834
+ 3	20,90		2,95	1262	997	1131	876	1071	818	1052	805	932	707	986	762
+ 2	17,95		2,95	1158	900	1042	792	991	742	974	731	860	640	907	689
+ 1	15,00		2,95	1067	814	953	709	910	668	896	659	787	573	841	628
-	12,05		2,95	977	730	803	571	773	542	766	541	666	464	774	567

**BOOSTER HEM 1,70 m  CITY**

<b>E</b>		 1,7 m CITY		Base on steel pads - L 4,5 x 4,5 m -  EN14439 C25											
EI	HT		Δ	Jib 50 m		Jib 45 m		Jib 40 m		Jib 35 m		Jib 30 m		Jib 26 m	
n.	(m)		(m)	Z (t)	F1↓(kN)	Z (t)	F1↓(kN)	Z (t)	F1↓(kN)	Z (t)	F1↓(kN)	Z (t)	F1↓(kN)	Z (t)	F1↓(kN)
+ 8	36,70		2,95											102,0	990
+ 7	33,75		2,95					112,2	1046	102,0	948	102,0	911		
+ 6	30,80		2,95					112,2	998	102,0	958	91,8	865	91,8	833
+ 5	27,85		2,95			102,0	968	102,0	912	102,0	881	91,8	793	91,8	764
+ 4	24,90		2,95	102,0	917	102,0	889	102,0	838	102,0	810	91,8	726	81,6	696
+ 3	21,95		2,95	91,8	836	91,8	810	91,8	764	91,8	744	81,6	661	81,6	647
+ 2	19,00		2,95	91,8	765	91,8	741	91,8	717	91,8	706	81,6	629	81,6	618
+ 1	16,05		2,95	91,8	717	91,8	705	91,8	688	91,8	676	81,6	601	81,6	594
-	13,10		2,95	91,8	683	91,8	672	91,8	656	91,8	647	81,6	577	81,6	568

<b>D2</b>		 1,7 m CITY		Crane on embedded element - Booster HEM -  EN14439 C25											
EI	HT		Δ	Jib 50 m		Jib 45 m		Jib 40 m		Jib 35 m		Jib 30 m		Jib 26 m	
n.	(m)		(m)	F1↓(kN)	F2↑(kN)	F1↓(kN)	F2↑(kN)	F1↓(kN)	F2↑(kN)	F1↓(kN)	F2↑(kN)	F1↓(kN)	F2↑(kN)	F1↓(kN)	F2↑(kN)
+ 12	47,45		2,95											2121	1838
+ 11	44,50		2,95							2083	1784	1857	1580	1868	1591
+ 10	41,55		2,95					2250	1951	1887	1593	1691	1421	1726	1456
+ 9	38,60		2,95			2049	1754	1971	1679	1739	1452				
+ 8	35,65		2,95	2352	2048	1783	1495	1731	1446	1601	1321				
+ 7	32,70		2,95	1882	1592	1600	1319	1517	1238						
+ 6	29,75		2,95	1654	1370	737	522								
+ 5	26,80		2,95	729	511										



<b>D3</b>		☑ 2,1 m HC5S		Crane on embedded element - EN14439 C25											
EI	HT	☑	Δ	Jib 50 m		Jib 45 m		Jib 40 m		Jib 35 m		Jib 30 m		Jib 26 m	
n.	(m)		(m)	F1↓(kN)	F2↑(kN)	F1↓(kN)	F2↑(kN)	F1↓(kN)	F2↑(kN)	F1↓(kN)	F2↑(kN)	F1↓(kN)	F2↑(kN)	F1↓(kN)	F2↑(kN)
8	46,0	5S	2,95									-1833	1526	-1611	1311
7	43,1	5S	2,95							-1785	1464	-1638	1340	-1427	1136
6	40,1	5S	2,95					-1748	1429	-1592	1279	-1456	1165	-1255	972
5	37,2	5S	2,95	-1887	1571	-1757	1444	-1560	1248	-1411	1106	-1285	1002	-1094	819
4	34,2	5S	5,9	-1692	1384	-1568	1263	-1382	1079	-1241	944	-1124	850	-944	676
3	28,3	5S	5,9	-1336	1045	-1240	951	-1180	893	-934	653	-835	577	-747	447
2	22,4	5S	5,9	-1092	812	-1061	783	-1012	736	-733	414	-750	454	-684	396
1	16,5	5S	5,9	-925	661	-899	638	-860	601	-670	367	-690	410	-630	357

**BOOSTER - 2,10 m HC5S**

<b>D4</b>		☑ 2,1 m HC5S-B		Crane on embedded element - Booster EN14439 C25											
EI	HT	☑	Δ	Jib 50 m		Jib 45 m		Jib 40 m		Jib 35 m		Jib 30 m		Jib 26 m	
n.	(m)	(m)	(m)	F1↓(kN)	F2↑(kN)	F1↓(kN)	F2↑(kN)	F1↓(kN)	F2↑(kN)	F1↓(kN)	F2↑(kN)	F1↓(kN)	F2↑(kN)	F1↓(kN)	F2↑(kN)
11	54,9	5S	2,95									-2497	2170	-2240	1920
10	51,9	5S	2,95							-2444	2103	-2263	1945	-2018	1707
9	49	5S	2,95					-2393	2054	-2212	1879	-2043	1733	-1810	1506
8	46	5S	2,95	-2554	2219	-2404	2071	-2166	1835	-1993	1668				
7	43,1	5S	2,95	-2321	1993	-2177	1852	-1952	1629						
6	40	5S-B		-2100	1781	-1963	1647								

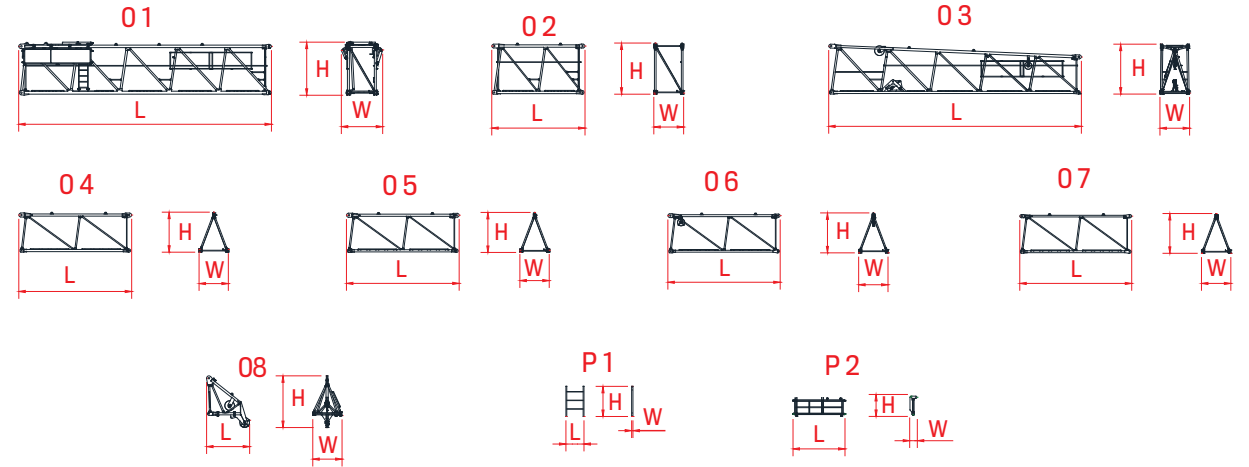

Jib elements LRH174

UNIT	POS.	QUANTITY	DIMENSIONS [ m ]			UNIT WEIGHT
			L	W	H	Kg
Jib element*	01	1	11 738	1 918	2 463	2 845
Jib element	02	1	4 328	1 385	2 374	723
Jib element*	03	1	11 733	1 378	2 315	1 805
Jib element	04	1	5 239	1 362	1 858	483
Jib element	05	1	5 234	1 362	1 858	402
Jib element	06	1	5 214	1 363	1 851	368
Jib element	07	1	5 199	1 363	1 845	300
Tip	08	1	2 000	1 362	2 398	
Tip uprights	P1	1	840	60	1 400	420
tip platform service	P2	1	1 951	263	701	

\* With platform and accessories

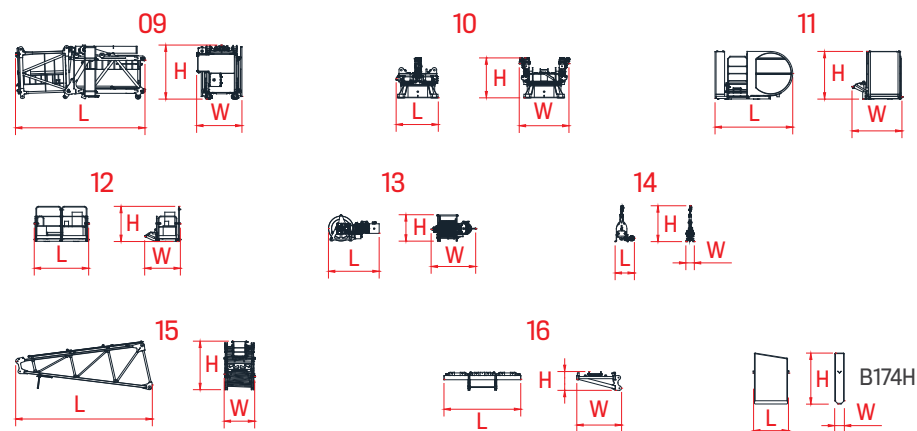

## List of packages at the top

UNIT	POS.	QUANTITY	DIMENSIONS [ m ]			UNIT WEIGHT Kg
			L	W	H	
Tilting group and cylinder	09	1	6 074	2 128	2 541	7 000
Swivel group	10	1	1 977	2 331	1 876	4 100
Balcony + cabin	11	1	3 644	2 341	2 245	1 650
Balcony + control unit	12	1	2 552	1 675	1 657	1 050
Hoisting winch + rope 45 kW	13	1	2 376	2 090	1 243	2 930
Hoisting winch 37 kW		1	2 380	2 090	2 550	2 550
Hook block	14	1	905	400	1 688	420
Initial counterjib element*	15	1	6 408	1 430	2 281	1 345
Counterweight frame	16	1	3 600	2 100	883	780

\* With platform and accessories



For different heights contact the technical department / Per altezze diverse contattare l'ufficio tecnico / Pour des hauteurs différentes contact le département technique / Für unterschiedliche Höhen Kontakt zum Technischen / Недопустимо увеличение высоты крана без согласования с технической службой производителя

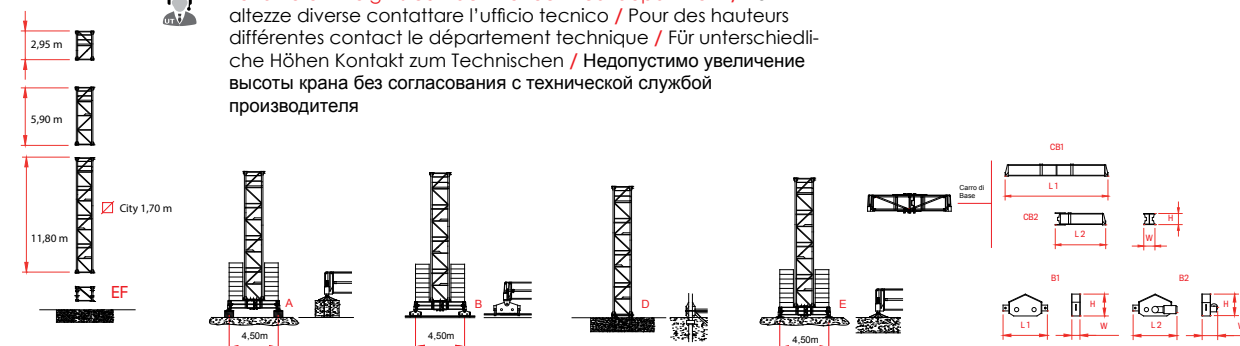

## Tower 1,7 m CITY

UNIT	POS.	QUANTITY	DIMENSIONS [ m ]			UNIT WEIGHT Kg
			L	W	H	
Tower el. 2,95 - City 1,70 m	-	1	1 900	1 700	1 400	-
Tower el. 5,90 - City 1,70 m	-	1	1 900	1 700	2 295	-
Tower el. 11,80 - City 1,70 m	-	1	1 900	1 700	4 175	-
Foundation element City	EF	1	1 465	1 980	1 980	830
Foundation element HEM120	EF	1	1 986	1 986	1 625	1 095
Crossbase long beam	CB1	1	6 530	0 780	0 960	2 595
Crossbase short beam	CB2	2	3 212	0 680	0 974	1 235
Driving bogie	B1	1	1 320	0 230	0 540	600
Driven bogie	B2	1	1 430	0 500	0 540	765
B5 - Block - 1,70 m CITY		1	3,6	0,9	0,75	5 520
GB5F - Base ballast		1	4 300	1 200	0 430	5 100
B174 - Counterweight block		1	1 670	440	2 395	3 400



LRH174 \_Jib 50 m •

Top part / Parte rotante / Partie tournante / Drehender Kranteil / Поворотная часть



1 x 40 OT

4 x 40 HC

1 x 20 Box

Included counter weight and cabin / Cabina e contrappesi inclusi / Cabine et contrepoids inclus / Kabine und Gegengewichts Blöcke – inbegriffen / Противовес включен - кабина





**RAIMONDI**®

SINCE 1863

**ACCESSORIES**

The Raimondi MRT152 topless tower crane erected in Sharjah, UAE





**BASE WITH STRUTS 8x8m GR6L**

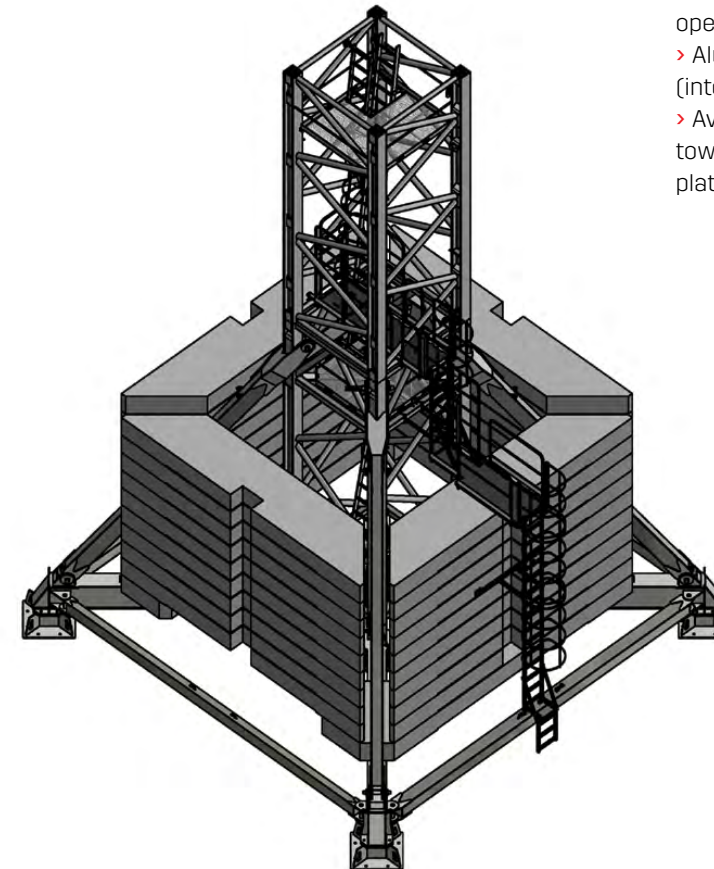

**ADVANTAGES**



- > Base with struts 8x8m complete with a 6m height tower sections type GR6L
- > An extremely high freestanding height can be reached using GR6L tower sections due to the optimized design and the high strength steel
- > All base details were designed to facilitate assembly operations and to reduce the time required
- > Aluminum ladders and hot galvanized rest platform (internal accessories) are removable
- > Available as an option as a system to climb the first tower section from the exterior. The ladders and the platforms are fully hot galvanized

**BASE 8X8 GR6L**

The load includes accessories but does not include base ballasts.

Optional:  
Complete external access to the first tower section.

 1 x 13,60 m  
1 x 3,00 m

 1 x 40 High cube  
 1 x 20 Box

For commercial enquiries contact  
[info@raimondicranes.com](mailto:info@raimondicranes.com)



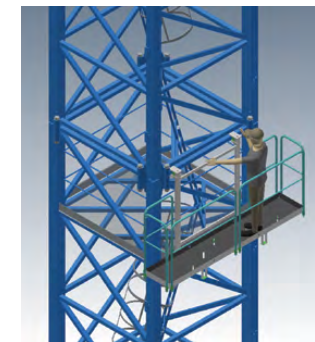
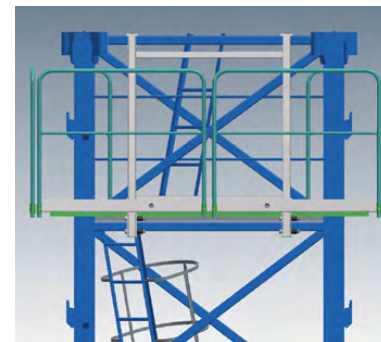
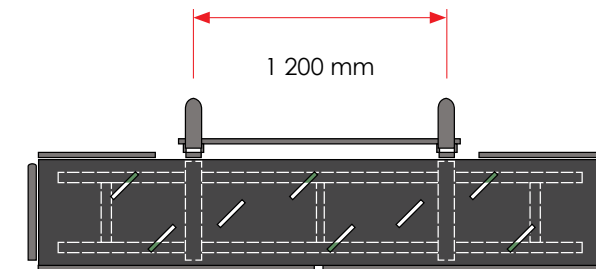
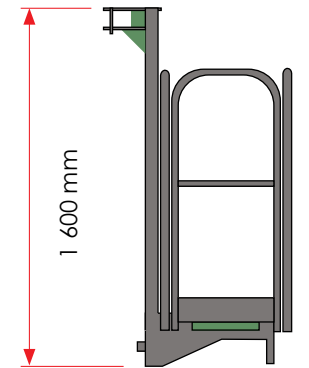
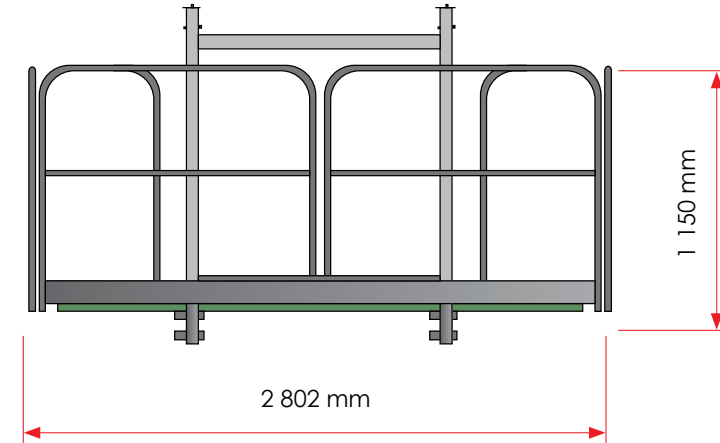

**ADVANTAGES**

- > Increased technician safety and comfort during the assembly and dismantle phases of the tower sections
- > The exceptional material quality and the hot galvanized process guarantee durability and longevity
- > Designed to reduce both transport dimensions and assembly times
- > The Service Balcony Kit may be used with different tower dimensions.

Raimondi supplies a kit with two balconies. Each balcony can be connected to the tower structure easily and fixed with pins.

For commercial enquiries contact [info@raimondicranes.com](mailto:info@raimondicranes.com)



**RAIMONDI**® TOWER CRANE LIFT  
SINCE 1863



The Raimondi SL20-TC crane elevator at Intermat Paris 2018

TOWER CRANE LIFT SL20 - TC

Characteristics	Model SL20 - TC	
Load capacity	Kg	200 / 2
Rated speed	m	24
Maximum height	m	150 (*)
Cabin size	m x m x m	1,2 x 0,6 x 2,1
Tie distance	m	4,5 - 6 (**)
Rated power	kW	3
Mast section length	m	1.47 / 1,9
Module		6
Power supply		400V 3P + N + PE 50/60 Hz
Control voltage	V	48
(*)	For higher values contact the Raimondi Cranes Technical Office	
(**)	After 6m contact the Raimondi Cranes Technical Office	

The Raimondi SL20-TC crane lift is designed to allow access to the top of the tower crane, and facilitates quick ascent to allow crane operators increased working hours and reduced physical fatigue. The elevator can be fitted to a range of existing brands and systems, boasting an exterior installation and adaptability to different tower sections without modifications of the mast structure, and has large tie distance for easy assembly. The SL20-TC can be erected from the cabin roof, and the light-weight ladder sections are ideal for manual assembly. The lift is accessed from the door facing the crane by a hinged ramp with lateral protections and a sliding door. The lift's roof is designed with a trapdoor to enable top access during assembly, and the trapdoor doubles as a safety measure in the event an emergency rescue is required. The elevator's vertical hose is guided with a trolley below the cabin to avoid entanglement. Reversible lift with access on the right or left of mast section to fit different tower crane systems. In addition, the SL20-TC elevator is fitted with front and side windows meant to facilitate easy crane inspection.



**FEATURES**

Tower modifications are not required. Assembly is simple and previous tower crane models can be retrofitted to accommodate the SL20-TC crane elevator. The SL20-TC is in compliance with Standard EN81-43: Crane Lifts - Safety Requirements.

- > A geared motor brake
- > Fall arrest device
- > Manual emergency descend
- > Rack inductive detector
- > Emergency stop
- > Travel limit switches
- > Buffers at travel limits
- > Non-slip floor
- > Cabin access door with electromechanical interlock
- > Access ramp with railings and limit switch
- > Top trapdoor with limit switch
- > Inside ladder for top access
- > Low voltage panel
- > Phase control
- > Cabin roof railing
- > Interior cabin lighting
- > Overload device
- > Liftway protection and landing gates

For commercial enquiries contact [info@raimondicranes.com](mailto:info@raimondicranes.com)





**RAIMONDI**<sup>®</sup> DELUXE R16 CABIN  
SINCE 1863



The Raimondi Cranes Deluxe R16 Crane Cabin fitted on the Raimondi LRH174 luffing hydraulic crane

The frontal and side windshields of the Raimondi Deluxe R16 Crane Cabin allow crane operators a full jobsite view as more than 80% of the total cabin surface is glass. Two-toned windshield glass was developed, ensuring interior cabin comfort while maintaining superior visibility. Keeping with the schema of increased viewing fields, the R16 cabin door is made fully of glass, providing crane operators an additional line of sight. One of the largest cabins available in today's crane marketplace, the Raimondi Deluxe R16's dimensions, at a height 2.07 meters, length of 2.135 meters and width of 1.40 meters, is highly comfortable and even allows for easy inter-cabin walking.



The Raimondi Deluxe R16 Cabin at Intermat Paris 2018



© All rights reserved Raimondi Cranes 2019



[www.raimondi.co](http://www.raimondi.co)



**Raimondi Cranes is proudly headquartered in our ancestral home of Legnano**

Corso Garibaldi, 253 - 20025 Legnano - Milan, Italy

T +39 0331 548 061 r.a. | +39 0331 545 308 r.a. | F +39 0331 450 400 | [info@raimondicranes.com](mailto:info@raimondicranes.com)

DATA SHEETS REV.00.2019 / ADL



**The data presented in the 2019 Product Guide is subject to change without prior notice. Being a non-binding commercial document, the reader is required to consult instruction manuals for all technical information.** / I dati oggetto della presente scheda potrebbero subire

modifiche senza preavviso. Essendo un documento commerciale non vincolante si fa obbligo di consultare il manuale di istruzioni per tutte le informazioni tecniche. / Les informations données dans les fiches présentes peuvent subir des modifications sans préavis. Étant un document commercial non contraignant, il est nécessaire de consulter le manuel d'instructions pour toutes les informations techniques. / Die daten der vorliegenden blätter könnten ohne vorankündigung geändert werden. Unverbindliches Vertriebsdokument. Für technische Informationen, siehe die entsprechenden Anweisungen. / данные, указанные в настоящих спецификациях, могут изменяться без предварительного предупреждения. Этот коммерческий документ не является юридически обязательным. Для получения технической информации, см. соответствующие инструкции.





**RAIMONDI**®

SINCE 1863

[www.raimondi.co](http://www.raimondi.co)

**Raimondi Cranes is proudly headquartered  
in our ancestral home of Legnano**

Corso Garibaldi, 253 - 20025 Legnano, Milan, Italy  
+39 0331 548 061 | [info@raimondicranes.com](mailto:info@raimondicranes.com)

RAIMONDI

XCS1001

RAIMONDI

XCS1001